

20 STERN AVE.  
 SPRINGFIELD, NEW JERSEY 07081  
 U.S.A.

TELEPHONE: (973) 376-2922  
 (212) 227-6005

## Silicon Controlled Rectifiers Reverse Blocking Triode Thyristors

... designed primarily for half-wave ac control applications, such as motor controls, heating controls and power supplies; or wherever half-wave silicon gate-controlled, solid-state devices are needed.

- Glass Passivated Junctions with Center Gate Fire for Greater Parameter Uniformity and Stability
- Small, Rugged, Thermowatt Construction for Low Thermal Resistance, High Heat Dissipation and Durability
- Blocking Voltage to 800 Volts

**S2800  
 Series**

**SCRs  
 10 AMPERES RMS  
 50 thru 800 VOLTS**

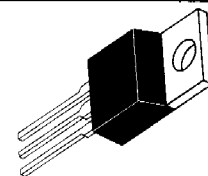

(TO-220AB)

**MAXIMUM RATINGS** ( $T_J = 25^\circ\text{C}$  unless otherwise noted.)

Rating	Symbol	Value	Unit
Peak Repetitive Forward and Reverse Blocking Voltage <sup>(1)</sup> ( $T_J = 25$ to $100^\circ\text{C}$ , Gate Open)	$V_{RRM}$ $V_{DRM}$		Volts
S2800	F A B D M N	50 100 200 400 600 800	
Peak Non-repetitive Reverse Voltage and Non-Repetitive Off-State Voltage <sup>(1)</sup>	$V_{RSM}$ $V_{DSM}$		Volts
S2800	F A B D M N	75 125 250 500 700 900	
RMS Forward Current (All Conduction Angles)	$I_T(\text{RMS})$	10	Amps
$T_C = 75^\circ\text{C}$			
Peak Forward Surge Current (1 Cycle, Sine Wave, 60 Hz, $T_C = 80^\circ\text{C}$ )	$I_{TSM}$	100	Amps
Circuit Fusing Considerations ( $t = 8.3$ ms)	$I^2t$	40	$\text{A}^2\text{s}$
Forward Peak Gate Power ( $t \leq 10$ $\mu\text{s}$ )	$P_{GM}$	16	Watts
Forward Average Gate Power	$P_{G(AV)}$	0.5	Watt
Operating Junction Temperature Range	$T_J$	-40 to +100	$^\circ\text{C}$
Storage Temperature Range	$T_{stg}$	-40 to +150	$^\circ\text{C}$

1.  $V_{DRM}$  and  $V_{RRM}$  for all types can be applied on a continuous basis. Ratings apply for zero or negative gate voltage; however, positive gate voltage shall not be applied concurrent with negative potential on the anode. Blocking voltages shall not be tested with a constant current source such that the voltage ratings of the devices are exceeded.

## S2800 Series

### THERMAL CHARACTERISTICS

Characteristic	Symbol	Max	Unit
Thermal Resistance, Junction to Case	$R_{\theta JC}$	2	$^{\circ}C/W$

### ELECTRICAL CHARACTERISTICS ( $T_C = 25^{\circ}C$ unless otherwise noted.)

Characteristic	Symbol	Min	Typ	Max	Unit
Peak Forward or Reverse Blocking Current ( $V_{AK} = \text{Rated } V_{DRM} \text{ or } V_{RRM}, \text{ Gate Open}$ ) $T_C = 25^{\circ}C$ $T_C = 100^{\circ}C$	$I_{DRM}, I_{RRM}$	— —	— —	10 2	$\mu A$ mA
Instantaneous On-State Voltage, ( $I_{TM} = 30 \text{ A Peak, Pulse Width } \leq 1 \text{ ms, Duty Cycle } \leq 2\%$ )	$V_T$	—	1.7	2	Volts
Gate Trigger Current (Continuous dc) ( $V_D = 12 \text{ Vdc, } R_L = 30 \text{ Ohms}$ )	$I_{GT}$	—	8	15	mA
Gate Trigger Voltage (Continuous dc) ( $V_D = 12 \text{ Vdc, } R_L = 30 \text{ Ohms}$ )	$V_{GT}$	—	0.9	1.5	Volts
Holding Current (Gate Open, $V_D = 12 \text{ Vdc, } I_T = 150 \text{ mA}$ )	$I_H$	—	10	20	mA
Gate Controlled Turn-On Time ( $V_D = \text{Rated } V_{DRM}, I_{TM} = 2 \text{ A, } I_{GR} = 80 \text{ mA}$ )	$t_{gt}$	—	1.6	—	$\mu s$
Circuit Commutated Turn-Off Time ( $V_D = V_{DRM}, I_{TM} = 2 \text{ A, Pulse Width} = 50 \mu s,$ $dv/dt = 200 \text{ V}/\mu s, di/dt = 10 \text{ A}/\mu s, T_C = 75^{\circ}C$ )	$t_q$	—	25	—	$\mu s$
Critical Rate-of-Rise of Off-State Voltage ( $V_D = \text{Rated } V_{DRM}, \text{ Exponential Rise, } T_C = 100^{\circ}C$ )	$dv/dt$	—	100	—	$V/\mu s$

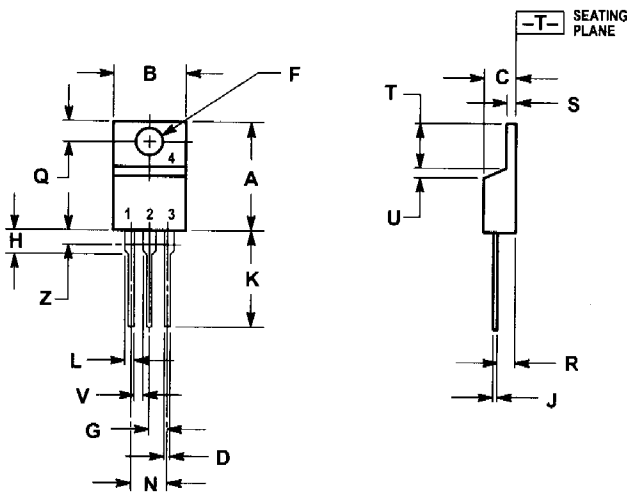

#### NOTES:

- DIMENSIONING AND TOLERANCING PER ANSI Y14.5M, 1982.
- CONTROLLING DIMENSION: INCH.
- DIMENSION Z DEFINES A ZONE WHERE ALL BODY AND LEAD IRREGULARITIES ARE ALLOWED.

DIM	INCHES		MILLIMETERS	
	MIN	MAX	MIN	MAX
A	0.570	0.620	14.48	15.75
B	0.380	0.405	9.66	10.28
C	0.160	0.190	4.07	4.82
D	0.025	0.035	0.64	0.88
F	0.142	0.147	3.61	3.73
G	0.095	0.105	2.42	2.66
H	0.110	0.155	2.80	3.93
J	0.014	0.022	0.36	0.55
K	0.500	0.562	12.70	14.27
L	0.045	0.055	1.15	1.39
N	0.190	0.210	4.83	5.33
Q	0.100	0.120	2.54	3.04
R	0.080	0.110	2.04	2.79
S	0.045	0.055	1.15	1.39
T	0.235	0.255	5.97	6.47
U	0.000	0.050	0.00	1.27
V	0.045	—	1.15	—
Z	—	0.080	—	2.04