



ELECTRONICS, INC.
 44 FARRAND STREET
 BLOOMFIELD, NJ 07003
 (973) 748-5089
<http://www.nteinc.com>

NTE7011 Integrated Circuit 20W Audio Power Amplifier Circuit

Description:

The NTE7011 is an integrated circuit in a 12-Lead SIP type package designed for use as a BTL power amplifier with built-in headphone amp for portable stereo applications. Typical applications include portable component stereos, car stereo, radio cassette recorders, and TV sound multiplex output.

Features:

- Low Quiescent Current, Low Distortion, Low Noise, High Output Power
- Wide Supply Voltage range: $V_{CC} = 6$ to 26V
- Built-In Muting Circuit
- Built-In Protection Circuits:
 Temperature, Surge, Overcurrent
- Built-In Headphone Amplifier Circuit

Absolute Maximum Ratings: ($T_A = +25^\circ\text{C}$ unless otherwise specified)

Supply Voltage, V_{CC}	26V
Peak Supply Voltage, $V_{CC(\text{surge})}$	50V
Supply Current, I_{CC}	4A
Power Dissipation, P_D	35.7W
Operating Ambient Temperature, T_{opr}	-30° to +75°C
Storage Temperature, T_{stg}	-55° to +150°C

Electrical Characteristics: ($V_{CC} = 15\text{V}$, $f = 1\text{kHz}$, $T_A = +25^\circ\text{C}$ unless otherwise specified)

Parameter	Symbol	Test Conditions	Min	Typ	Max	Unit
Quiescent Circuit Current	I_{CQ}	$V_i = 0$, $R_L = 4\Omega$	-	45	75	mA
Power Amplifier						
Output Noise Voltage	V_{no}	$R_g = 10\text{k}\Omega$, $f = 15\text{Hz}$, to 30kHz, 12dB/OCT, $R_L = 4\Omega$	-	0.6	1.0	mV
Voltage Gain	G_V	$V_i = 5\text{mV}$, $R_L = 4\Omega$	48.5	50.5	52.5	dB
Total Harmonic Distortion	THD	$V_i = 5\text{mV}$, $R_L = 4\Omega$	-	0.15	0.5	%

Electrical Characteristics (Cont'd): ($V_{CC} = 15V$, $f = 1kHz$, $T_A = +25^\circ C$)

Parameter	Symbol	Test Conditions	Min	Typ	Max	Unit
Maximum Output Power	P_O	THD = 10%, $R_L = 4\Omega$	20	23	-	W
Output Offset Voltage	$V_{O(offset)}$	$R_g = 0\Omega$	-	-	150	mV
Headphone Amp						
Output Noise Voltage	V_{no-H}	$R_g = 10\Omega$, $f = 15Hz$, to 30kHz, 12dB/OCT, $R_L = 33\Omega$	-	0.1	1.0	mV
Voltage Gain	G_{V-H}	$V_i = 10mV$, $R_L = 33\Omega$	17.5	19.5	21.5	dB
Maximum Output Power	P_{O-H}	THD = 1%, $R_L = 33\Omega$	10	-	-	mW

Block Diagram

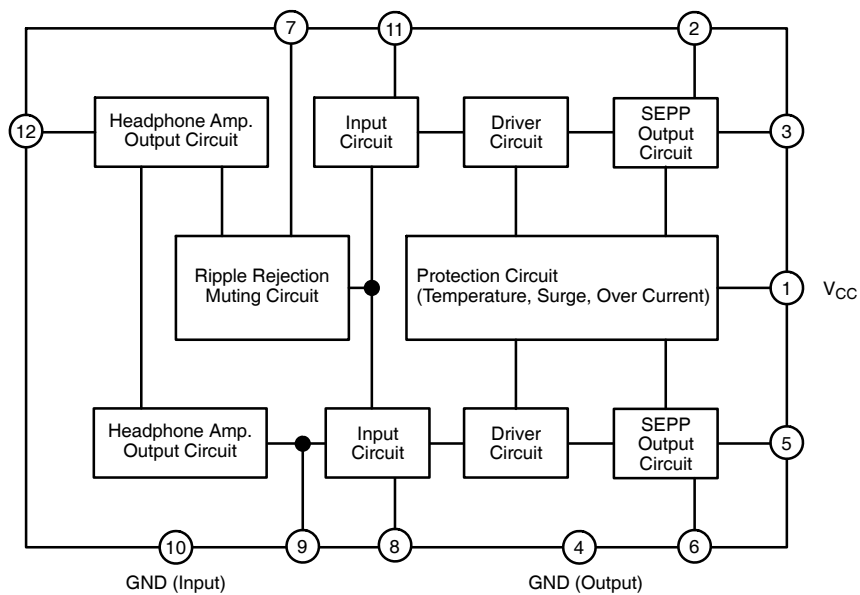

Pin Connection Diagram

