

KINGSTATE

PIEZO AUDIO TRANSDUCER

EXTERNAL DRIVE TYPE

Shape

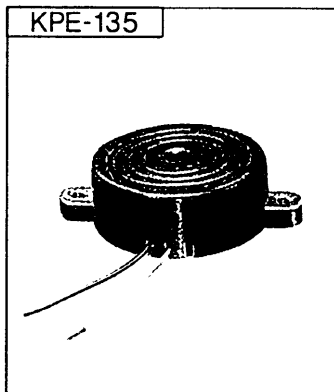
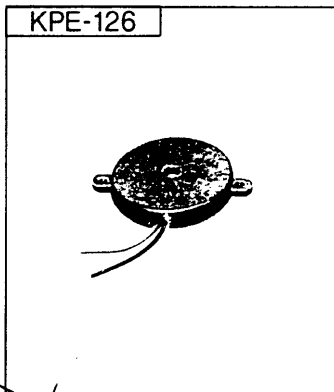
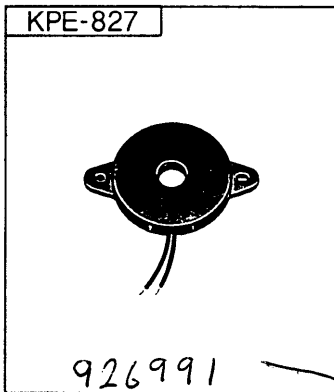
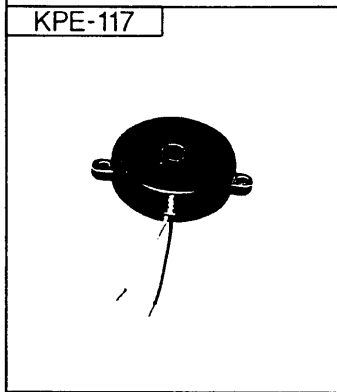

926991

Model Number	KPE-117	KPE-827	KPE-126	KPE-135
Operating Voltage (Vp-p maximum)	30	50	30	30
Sound Pressure Level at 10cm/10Vp-p square wave (dB, minimum)	86 at 2.5KHz	100 at 4.5KHz	90 at 2.8KHz	96 at 3.0KHz
Current Consumption at 10Vp-p square wave (mA, maximum)	9 at 2.5KHz	9 at 4.5KHz	8 at 2.8KHz	9 at 3.0KHz
Capacitance (± 30%pF)	25,000	16,500	18,000	25,000
Operating Temperature (°C)	-20~+60	-20~+60	-20~+60	-20~+60
Storage Temperature (°C)	-30~+70	-30~+70	-30~+70	-30~+70
Weight (Gram)	4.3	4.7	5.6	11.6
Packing Quantity (PCS/BOX)	250	400	400	100

Dimension

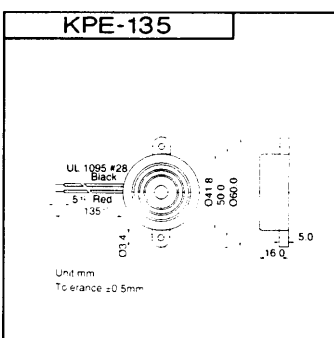
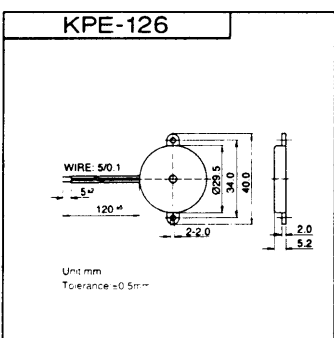
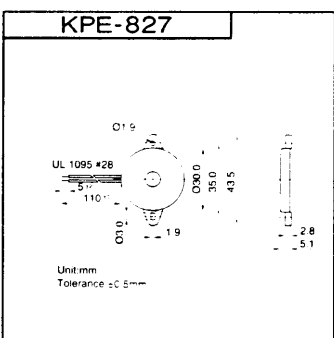
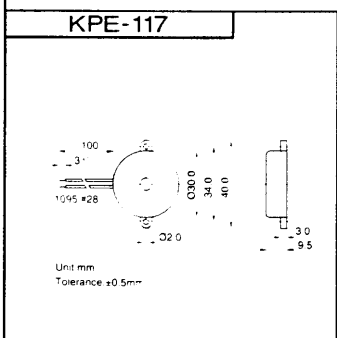

Frequency Curve

