

Transistors

silicon n-p-n power transistors

book 1 parts 1 and 2

Outline: TO-3

Type No.	Drawing reference	Maximum Ratings						hFE		at		V _{CE(sat)}		at		Special Features
		V _{CEO}	V _{CE0}	I _{CM}	I _{C(AV)}	T _j	P _{Tot}	min.	max.	I _c	f _t	min.	max.	I _c	I _B	
		(V)	(V)	(A)	(A)	(°C)	(W)			(A)	(MHz)	(V)	(A)	(mA)		
BDY38	AR3	50	40	6	6	200	115	30	—	2	1.0*	0.7	2	200		
BD181	AR2	55	45	15	10	200	78	20	70	3	—	—	—	—	For use in high quality audio amplifiers.	
BD182		70	60	15	117					4						
BD183		85	80	15	117					3						
BDY20	AR3	100	60	15	15	200	115	20	70	4	1.0*	1.1	4	400		
2N3055	AR3	100	60	—	15	200	115	20	70	4	0.8	1.1	4	400		
BUX80	AR1	800†	400	15	10	150	100	30*	—	1.2	6.0*	1.5	5	1A	For use in switched mode power supplies, inverters and converters.	
BUX81		1000†	450													
BDX91	AR3	60	60	12	8	200	90	20	—	3	4.0	1.0	5	1A	BDX92 } p-n-p BDX94 } complements BDX96 }	
BDX93		80	80													
BDX95		100	100													
§BUY86	AR3	200	120	15	7	150	62.5	50	—	1	45	1.0	7	700	For use in switched mode power supplies, inverters and converters.	
§BUY87		300	150					30	—	2		1.3				
BU326	AR1	800†	375	8	6	150	60	30*	—	0.6	6.0*	1.0	2.5	250	For use in switched mode power supplies of colour tv receivers	
BU326A		900†	400													
BUX82	AR1	800†	400	8	6	150	60	30*	—	0.6	6.0*	1.5	2.5	500	For use in switched mode power supplies, inverters and converters.	
BUX83		1000†	450													
BDY90	AR1	120	100	15	10	175	40	30	120	5	70*	0.5	5	500	For use in switched mode power supplies, inverters and converters	
BDY91		100	80													
BDY92		80	60													
BU126	AR1	750†	300	6	3	125	30	15	60	1	8.0*	10	2.5	250	For use in switched mode power supplies of colour tv receivers.	
BU133	AR1	750†	250	6	3	125	30	15	80	1	8.0*	10	2.5	250		
BDY93/01	AR1	800†	400	7	4	150	30	30*	—	1	10*	1.5	2.5	500		
BDY93		750†	350													
BDY94/01	AR1	800†	300	7	4	150	30	30*	—	1	10*	1.5	2.5	500	For use in converters, inverters, switching and motor control systems.	
BDY94		750†														
BDY96/01	AR1	800†	400	15	10	150	40	30*	—	2	10*	1.5	5	1A		
BDY96		750†	350													
BDY97/01	AR1	800†	300	15	10	150	40	30*	—	2	10*	1.5	5	1A		
BDY97		750†														
BU132	AR1	800†	600	2	1	135	15	25	80	0.25	8*	5.0	0.25	25	For use in vertical deflection output stages of tv receivers.	
BU207A	AR1	1500†	600	7.5	5	115	12.5	2.5	—	4.5	7*	5.0	4.5	2A	For use in horizontal deflection circuits of colour tv receivers.	
BU208A		1500†	700	7.5	5					4.5	1.0	4.5	2A			
BU209A		1700†	800	6	4					3	5.0	3	1.3A			
BU208	AR1	1500†	700	7.5	5	115	12.5	2.25	—	4.5	7*	5.0	4.5	2A	For use in horizontal deflection circuits of colour tv receivers.	
BU204	AR1	1300†	600	3	2.5	115	10	2	—	2	7.5*	5.0	2	1A	For use in horizontal deflection circuits of tv receivers.	
BU205		1500†	700					2	—				1A			
BU206		1700†	800					1.8	—				1.1A			

*Typical V_{CESM} max. §Also available to BS9000 (see page 7)

OUTLINES and DIMENSIONS (millimetres)

A

B.S.3934 SO-16

DO-1
DO-2
DO-3

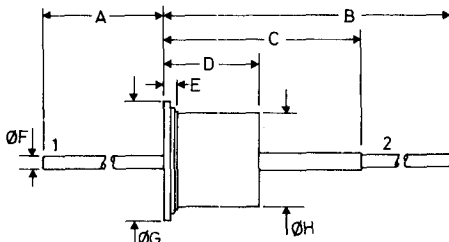

	1	2	A	B	C	D	E	ØF	ØG	ØH
	min.	max.	min.	max.	min.	max.	min.	max.	max.	max.
A1	a	k	35	51	17	7.7	1.6	1.1	9.6	7.1
A2	k	a	35	49	17	8.5	1.9	1.1	9.7	7.1
A3	k	a	35	51	17	7.7	1.6	1.1	9.6	7.1

B

B.S.3934 SO-10

DO-4

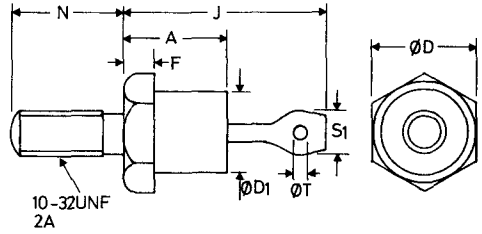

A	10.3 max.	J	20.3 max.
ØD	11.1 max.	N	11.5 max.
ØD1	9.3 max.	S1	4.8 max.
F	3.2	ØT	1.6 min.

	Stud	Eyelet
B1	k	a
B2	a	k

C

B.S.3934 SO-13

DO-5

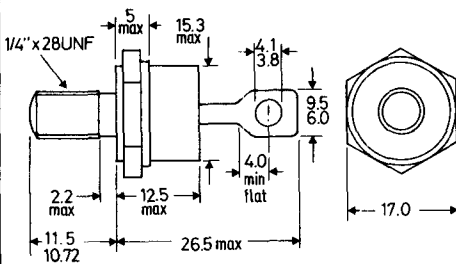

	Stud	Eyelet
C1	k	a
C2	a	k

D

DO-7
DO-14
DO-15

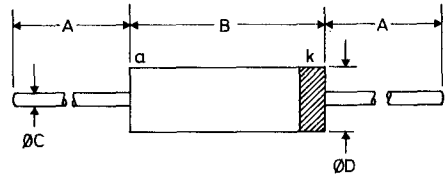

		A	B	ØC	ØD
		min.	max.	nom.	max.
D1	DO-7	25.4	7.6	0.52	2.5
D2	DO-14	25.4	7.6	0.5	3.3
D3	DO-15	25.4	6.4	0.8	3.2

E

DO-22
SOD-47

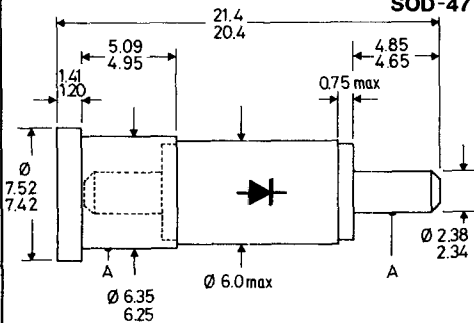

A = concentricity tolerance = ± 0.20

F

DO-30

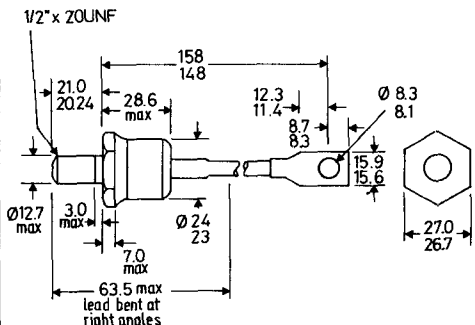

BZW86 Blue sleeve - anode to eyelet
BZW86R Red sleeve - anode to stud

These drawings give limited information for quick reference purposes. For equipment design more complete information should be obtained from individual data sheets in the Technical Handbook or from standard B.S. or JEDEC outline drawings.

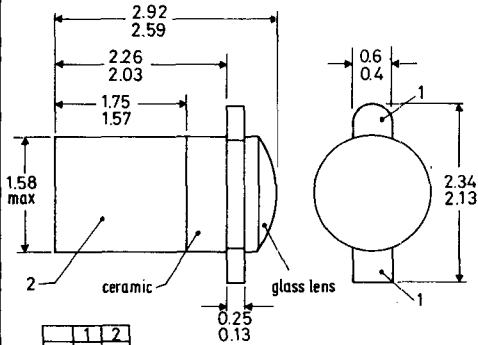
G**DO-31**

	1	2
G1	k	a
G2	e	c

For LED's the overall length = 3.60/2.97

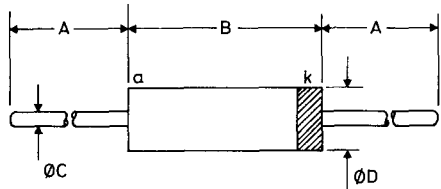
H**DO-35**

A	B	ØC	ØD
min.	max.	max.	max.
25.4	4.25	0.56	1.85

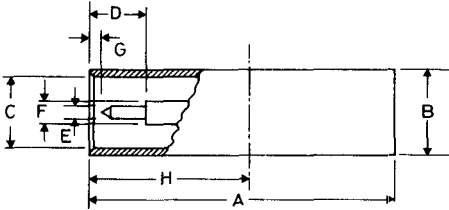
J**DO-37
SOD-49**

A	19.43/18.67	ØE	0.84/0.79
ØB*	5.59/5.49	ØF	1.57/1.52
ØC	4.80/4.72	G	0.71/0.15
D	3.73 min.	H	10.32 nom.

*These tolerances apply only over H

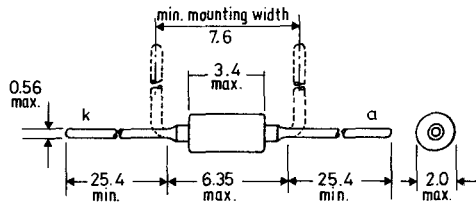
K**SOD-17**

Cathode indicated by the broad band of colour code

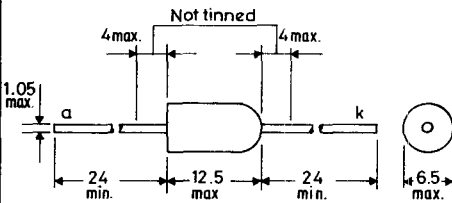
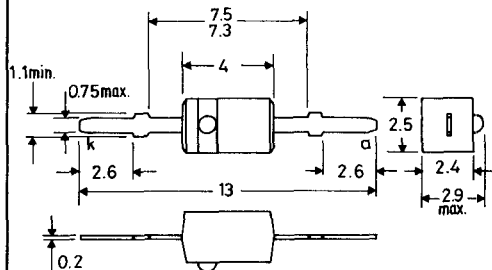
L**SOD-18****M****SOD-23**

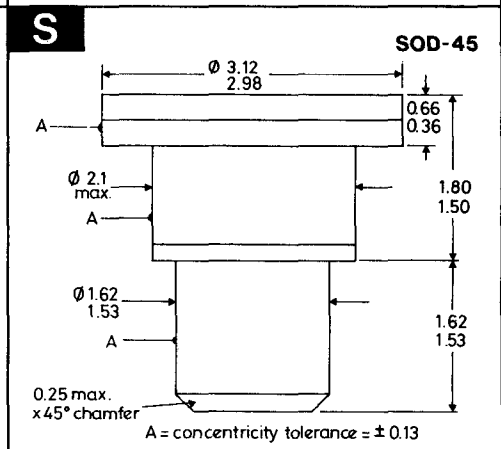
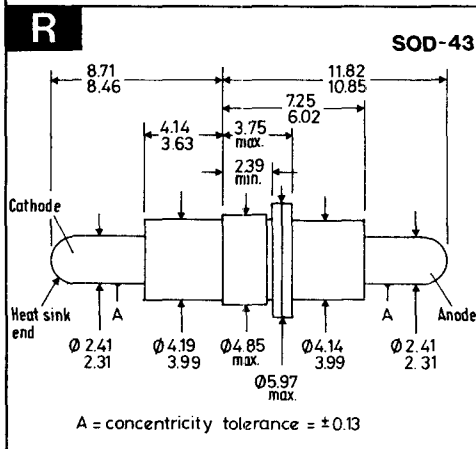
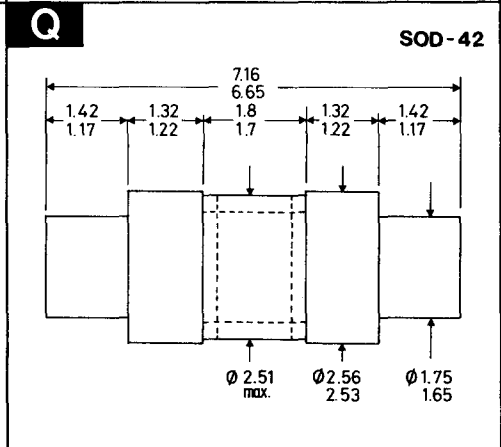
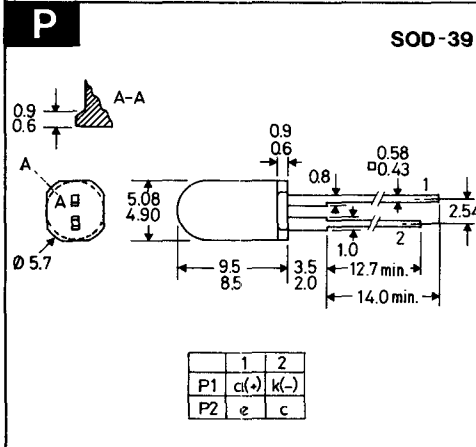
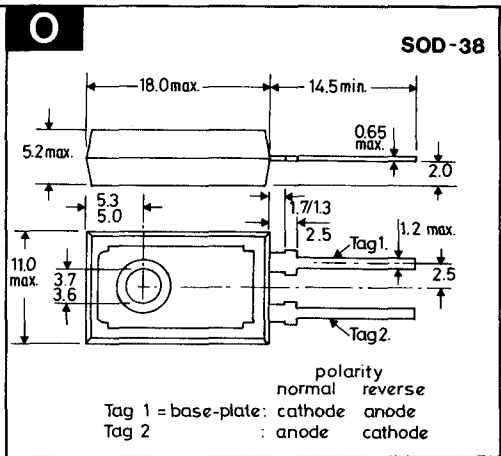
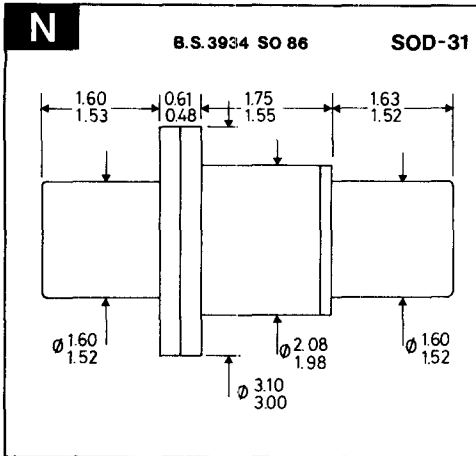

These drawings give limited information for quick reference purposes. For equipment design more complete information should be obtained from individual data sheets in the Technical Handbook or from standard B.S. or JEDEC outline drawings.

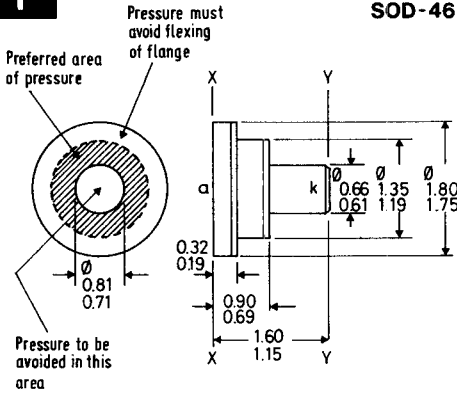
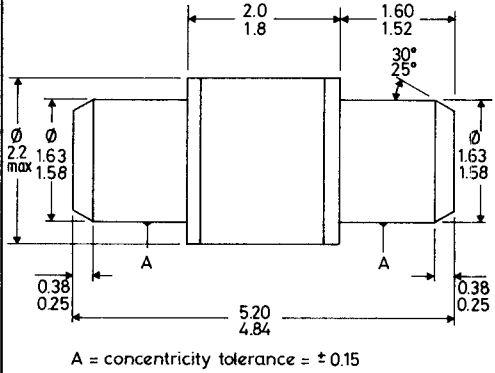
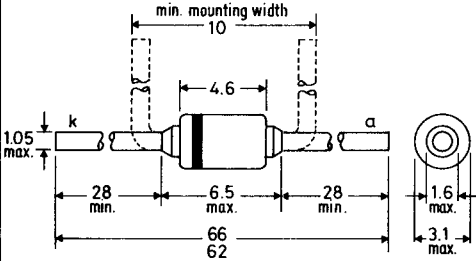
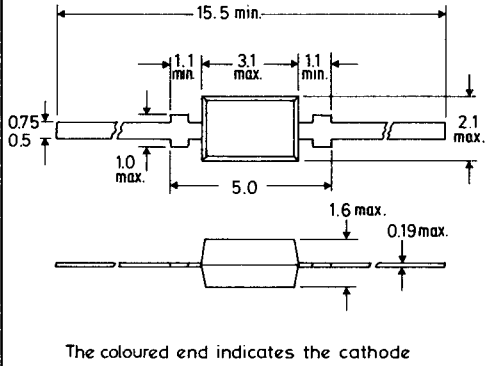
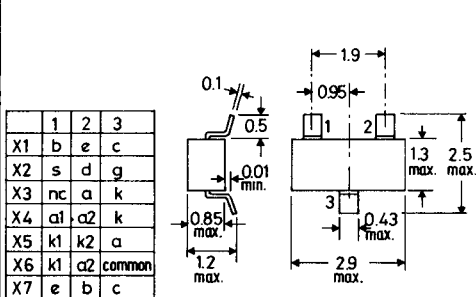
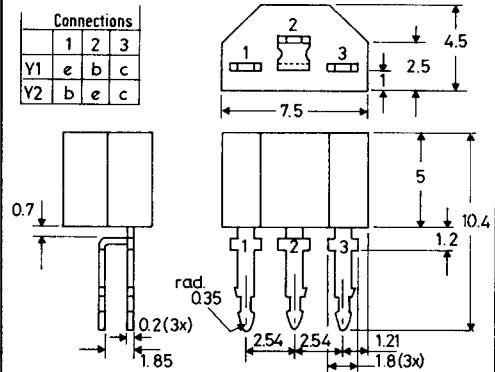
T**SOD-46****U****SOD-50****V****SOD-51****W****SOD-52****X****SOT-23****Y****SOT-25**

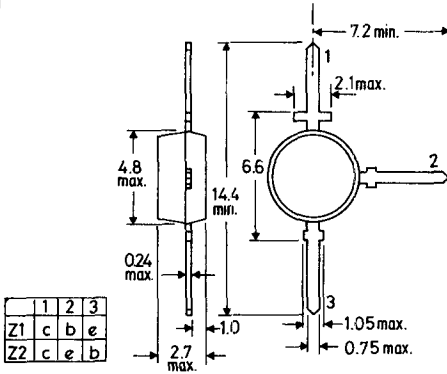
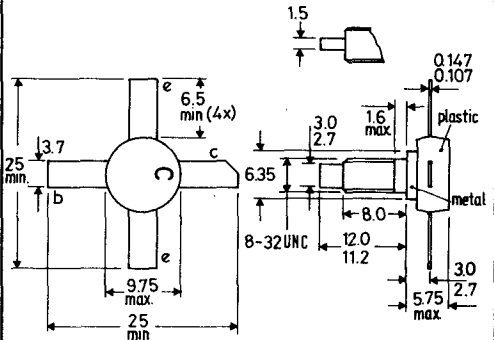
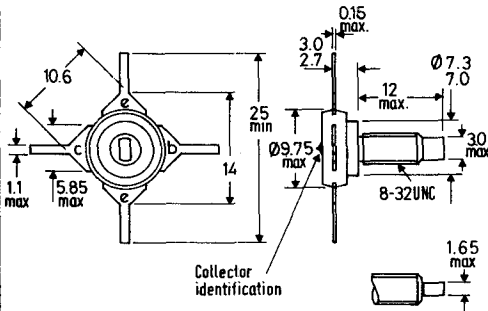
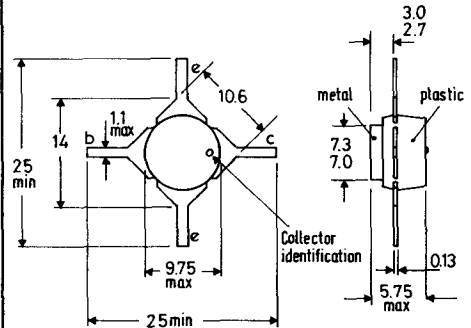
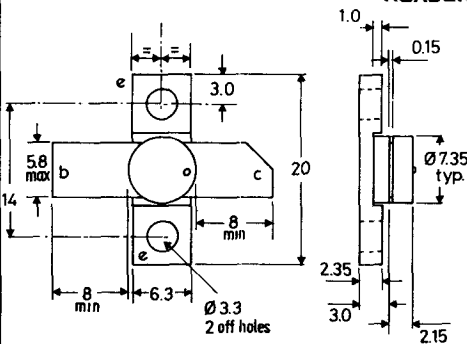
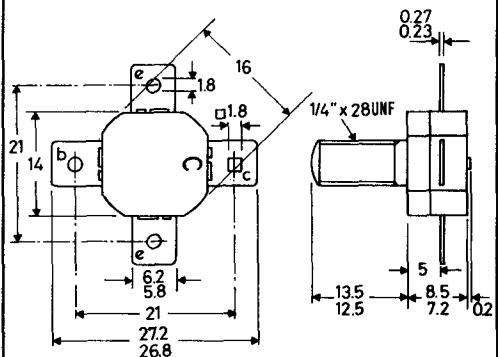
Z**SOT-37****AC****SOT-48/2****AD****SOT-48/3****AE****SOT-48/4****AF****SOT-48
HEADER****AG****SOT-55**

These drawings give limited information for quick reference purposes. For equipment design more complete information should be obtained from individual data sheets in the Technical Handbook or from standard B.S. or JEDEC outline drawings.

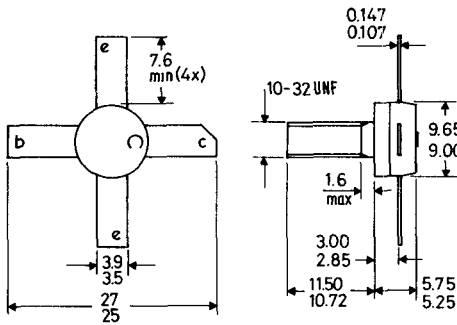
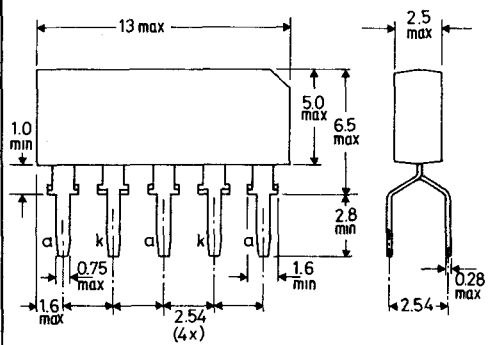
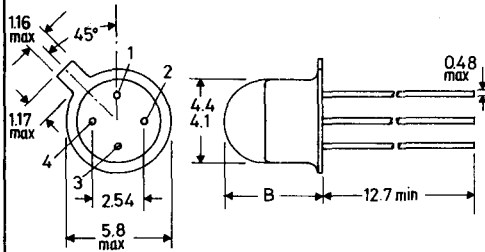
AH**SOT-56****AJ****SOT-60****AK****SOT-70**

	1	2	3	4	B max
AK1	a	—	k	—	5.08
AK2	e	b	c	—	4.5
AK3	Vp	IP	GND	OP	5.08

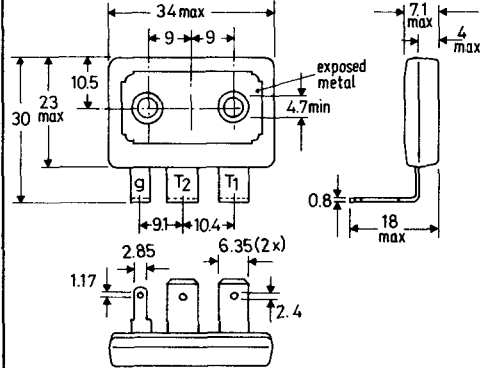
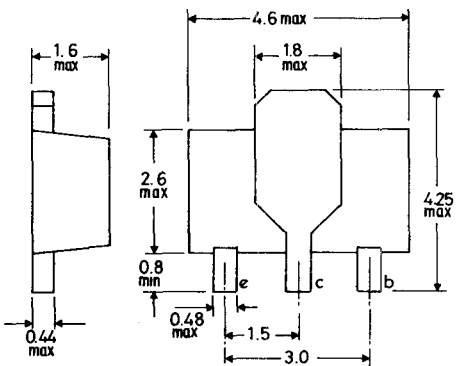
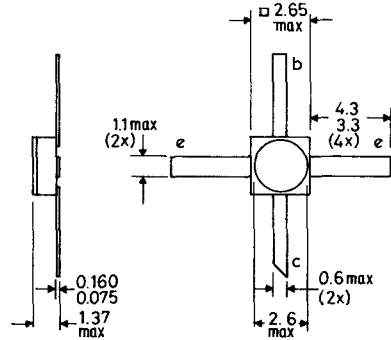
AL**SOT-80****AM****SOT-89****AN****SOT-100**

AO

SOT-103

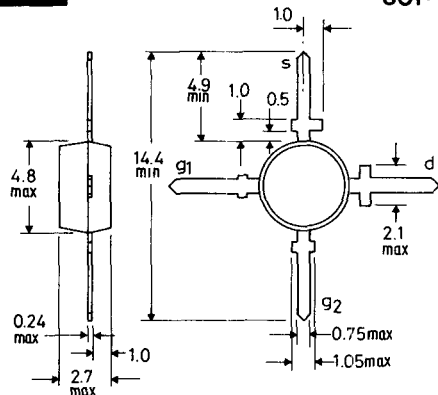

AP

SOT-105

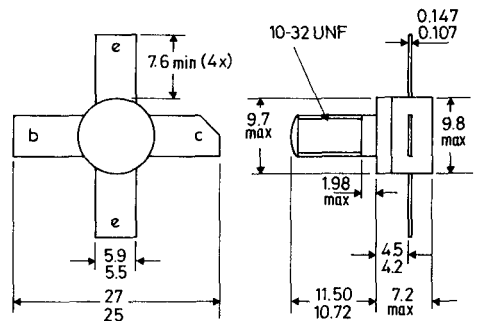

AQ

B.S.3934 SO-21/SB3-10 TO-1

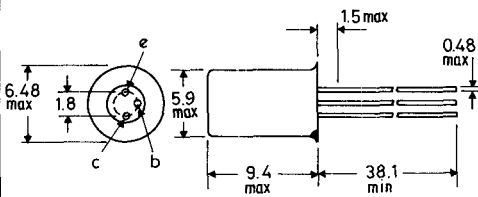

AR

B.S.3934 SO-5B/SB2-2 TO-3

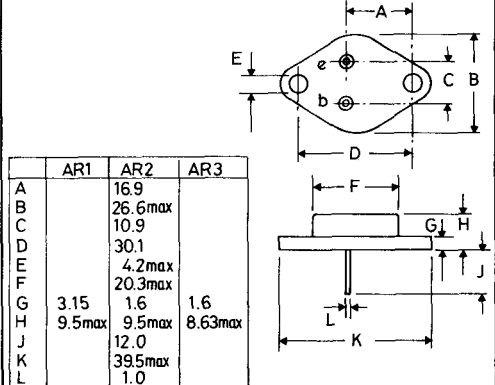

AS

B.S.3934 SO-3/SB3-3B TO-5

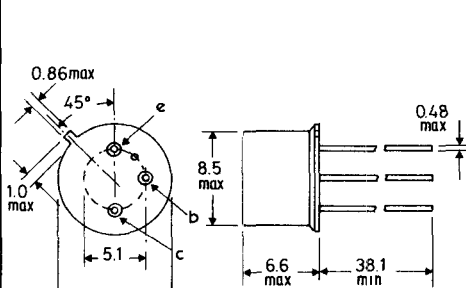

AS1: collector connected to case
AS2: base connected to case

AT

B.S.3934 SO-12A/SB3-6A TO-18

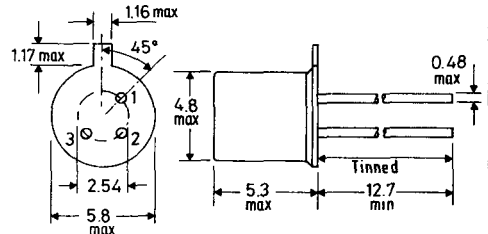

	1	2	3
AT1	e	b	c + env.
AT2	s	d	g + env.
AT3	d	g	s + env.
AT4	k	-	a
AT5	a	-	k
AT6	k	-	a

These drawings give limited information for quick reference purposes. For equipment design more complete information should be obtained from individual data sheets in the Technical Handbook or from standard B.S. or JEDEC outline drawings.

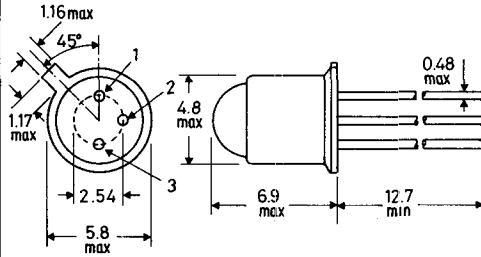
AU**TO-18**
(with lens)

	1	2	3
AU1	a	a	k
AU2	e	b	c+case
AU3	k	-	a

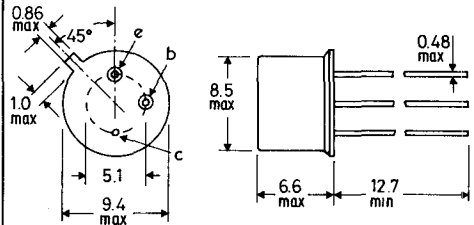
AV**B.S.3934 SO-3/SB3-3A TO-39**

AV1: b+case
 AV2: case isolated
 AV3: c+case
 AV4: e.cathode
 b.gate
 c.anode+case

AV5: e.b. cell connections
 c. metal case
 AV6: red spot indicates
 +ve connection

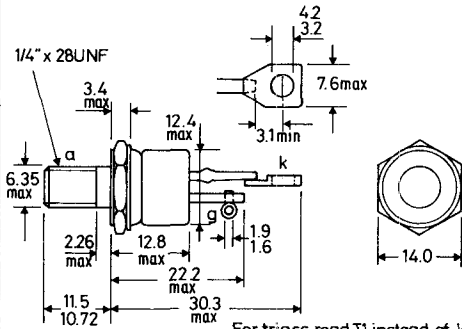
AW**B.S.3932 SO-36 TO-48**

For triacs read T1 instead of k
 T2 instead of a

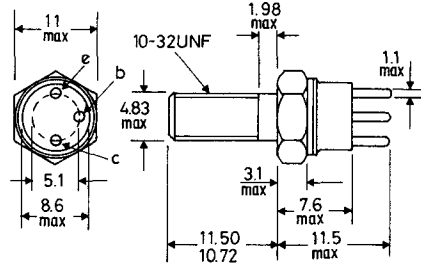
AX**TO-60**

Emitter connected to envelope

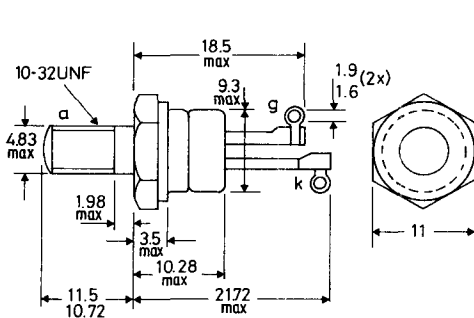
AY**B.S.3934 SO-35A TO-64**

For triacs read T1 instead of k
 T2 instead of a

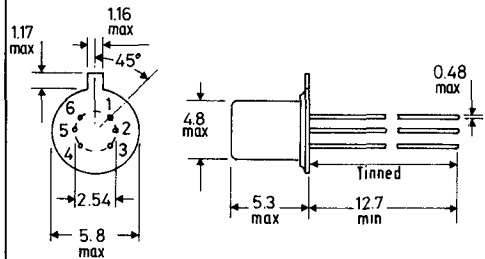
AZ**TO-71**

Pin	1	2	3	4	5	6
AZ1	e1	e2	c2	b2	b1	c1
AZ2	s1	d1	g1	s2	d2	g2

BA

B.S.3934 SO-12A/SB4-3 TO-72

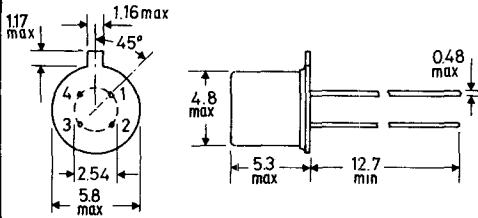

	1	2	3	4
BA1	b	e	c	s+envelope
BA2	e	b	c	s+envelope
BA3	s	d	g	screen+envelope
BA4	d	g	g	s+b+envelope
BA5	d	s	g	b+envelope
BA6	k	gk	ga	a

BBTO-92
variant

Pin	1	2	3
BB1	e	b	c
BB2	b	e	c
BB3	d	s	g
BB4	g	a	k
BB5	b	c	e

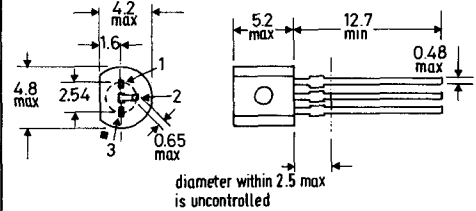
**BC**

B.S.3934 SO-30C TO-94

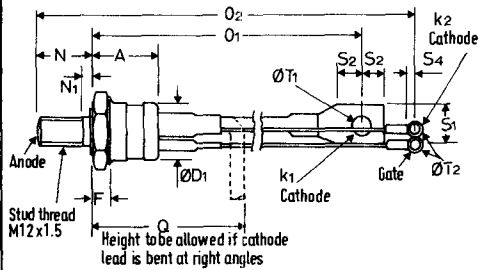

A	28.5max	O1	158 max	S4	3.8 min
ØD1	24.1max	O2	190max	ØT1	8.3max
F	8.9max	Q	63.5max	ØT2	4.2max
N	21.0max	S1	16.5max		
N1	3.0max	S2	9.6min		

BD

TO-103

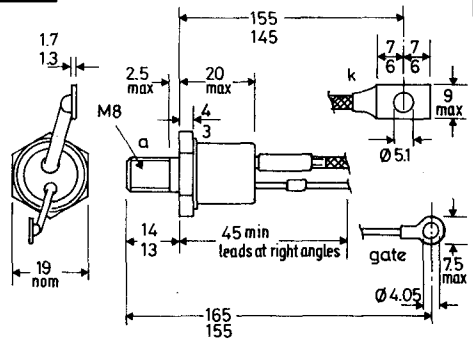
For triacs read T1 instead of k
T2 instead of a**BE**

TO-126

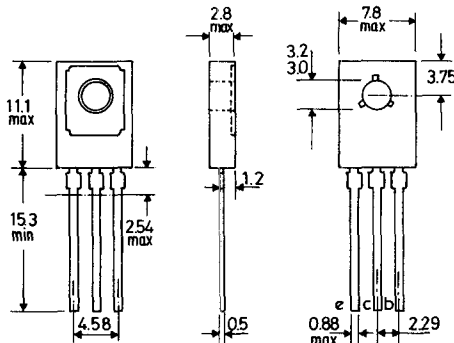
**BF**

TO-220

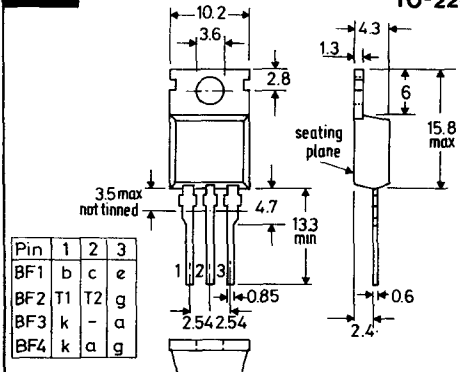

Pin	1	2	3
BF1	b	c	e
BF2	T1	T2	g
BF3	k	-	a
BF4	k	a	g

These drawings give limited information for quick reference purposes. For equipment design more complete information should be obtained from individual data sheets in the Technical Handbook or from standard B.S. or JEDEC outline drawings.

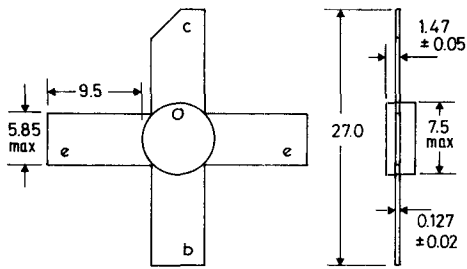
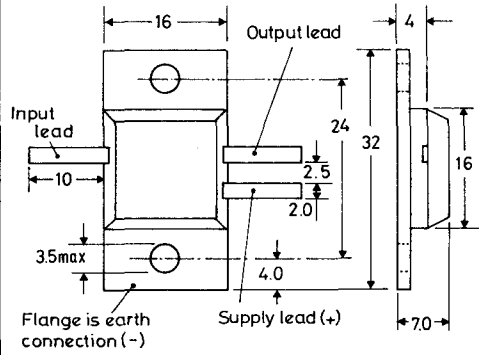
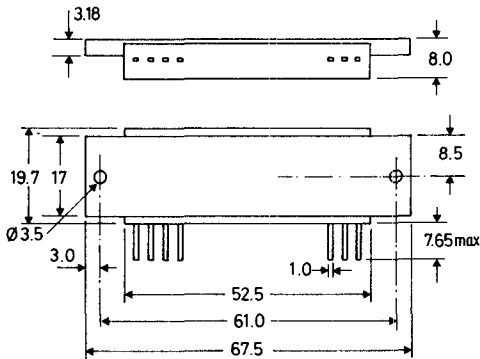
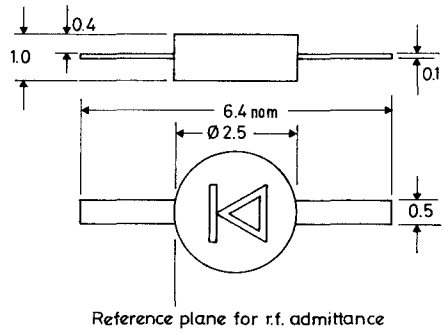
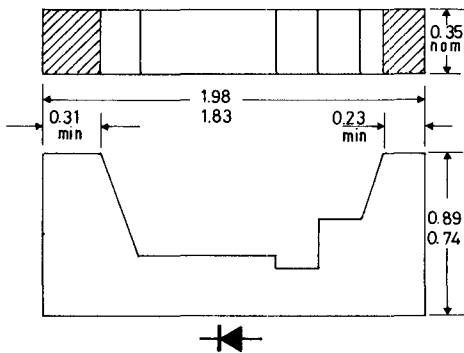
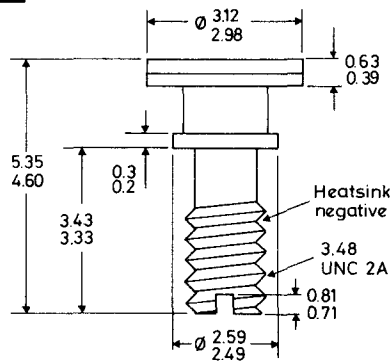
BG**BH****BJ****BK****BL****BM**

BN

B.S.3934

SO-26

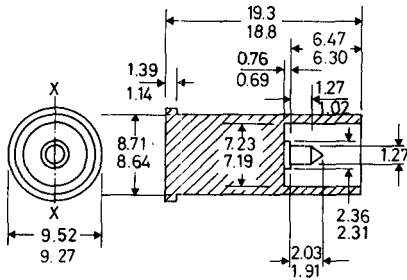

(All dimensions max.)

BO

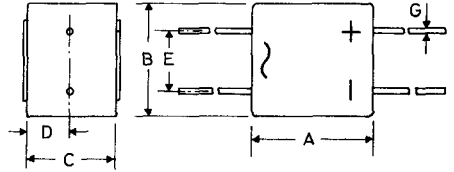

	BO1	BO2	BO3
A	12	20	12
B	10	19	10
C	8	15	8
D	4	7.5	4
E	5	10	5
F	58	60	48
G	0.75	1.0	1.1

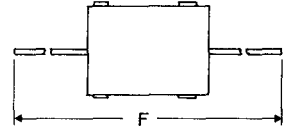

BP

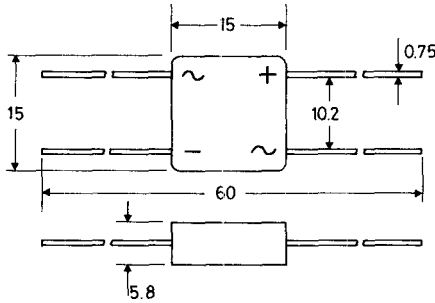

BQ

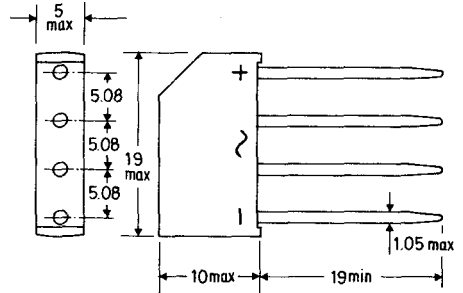

BR

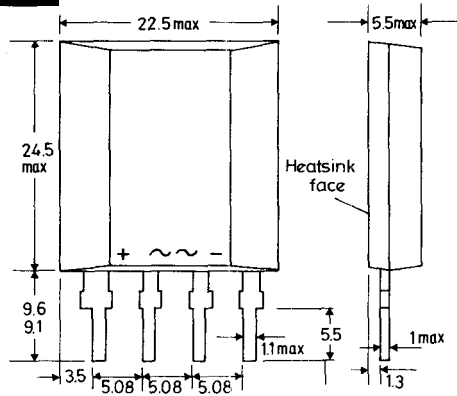

BS

B.S.3934 SO-67

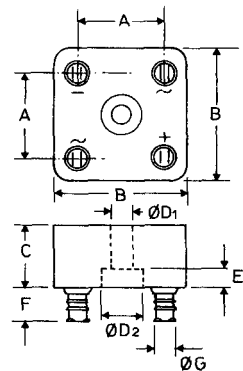

	BS1	BS2
	typ.	max.
A	23	21
B	35	34.6
C	17	15.2
ØD1	5	5.05
ØD2	11	11
E	5	3.7
F	9	9
ØG	4.8	4.8

These drawings give limited information for quick reference purposes. For equipment design more complete information should be obtained from individual data sheets in the Technical Handbook or from standard B.S. or JEDEC outline drawings.

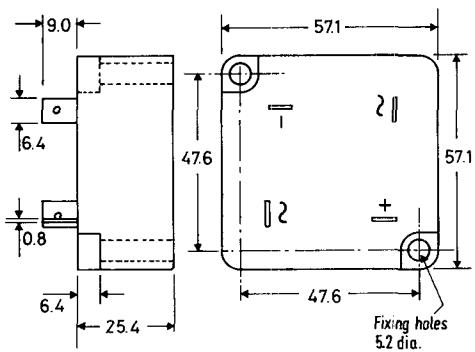
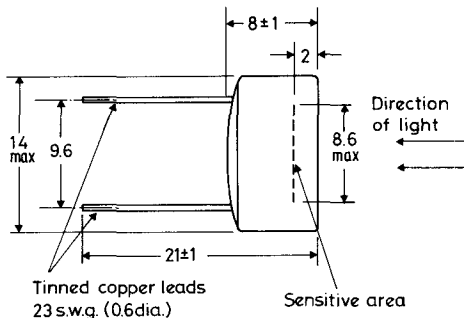
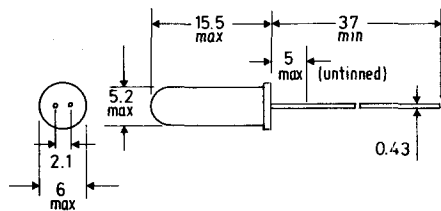
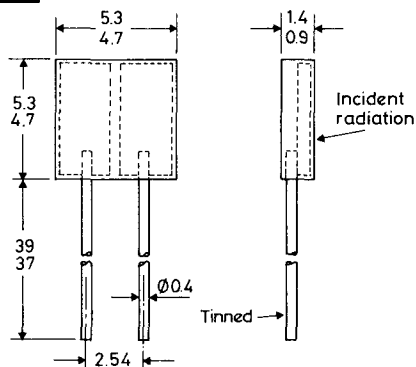
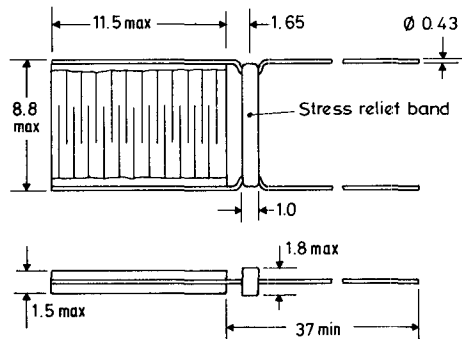
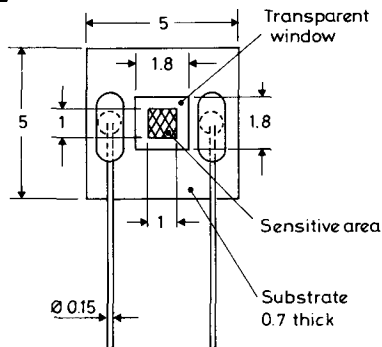
BT**BU****BV****BW****BX****BY**

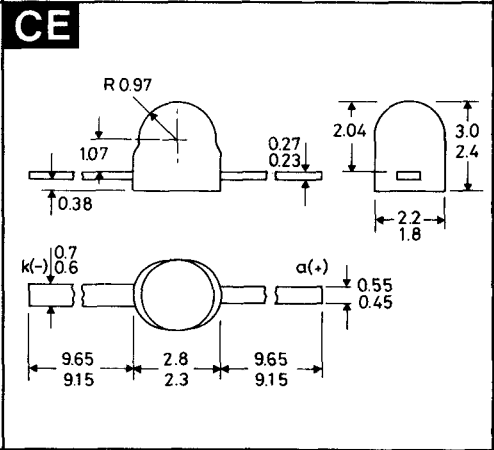
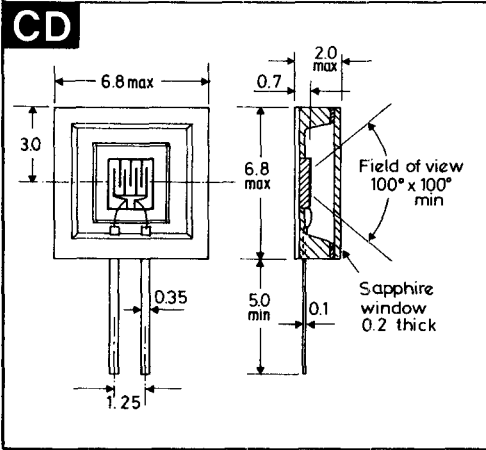
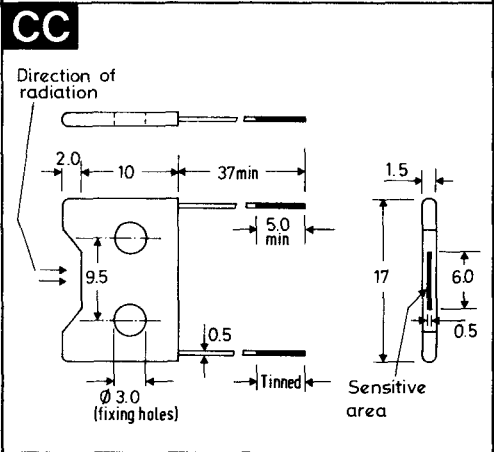
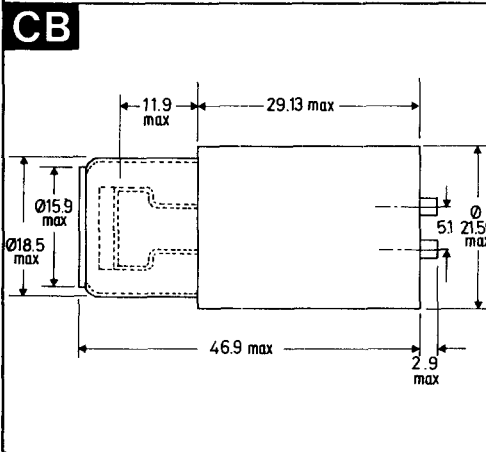
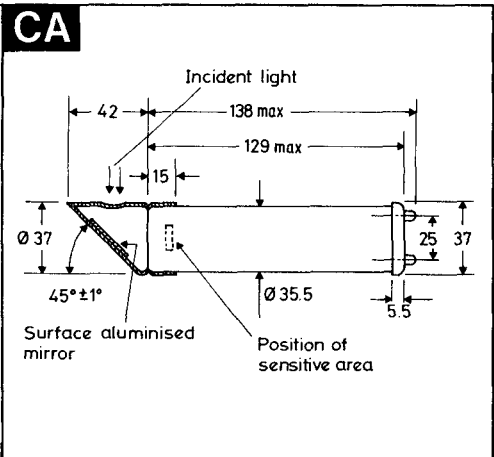
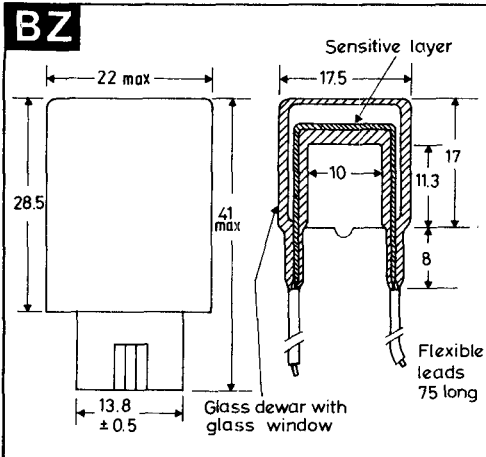

These drawings give limited information for quick reference purposes. For equipment design more complete information should be obtained from individual data sheets in the Technical Handbook or from standard B.S. or JEDEC outline drawings.

CF

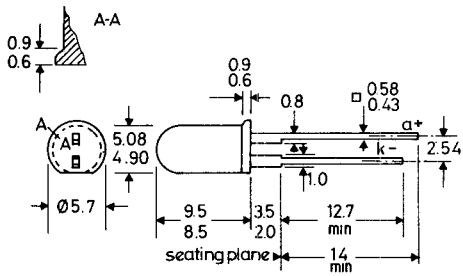

CG

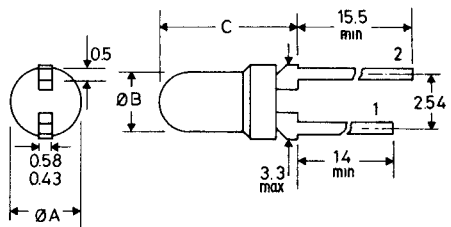

	1	2	$\varnothing A$	$\varnothing B$	C
CG1	k^-	a^+	3.0-3.17	2.4-2.6	5.8-6.3
CG2	a^+	k^-	3.0-3.17	2.4-2.6	5.8-6.3
CG3	k^-	a^+	3.3 max	2.65-3.17	4.8-6.3

CH

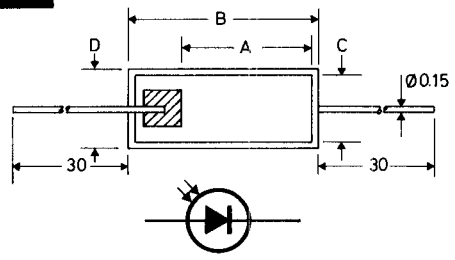

	CH1	CH2
A	2.2	3.5
B	3.35	4.55
C	0.95	1.85
D	1.25	2.15

CJ

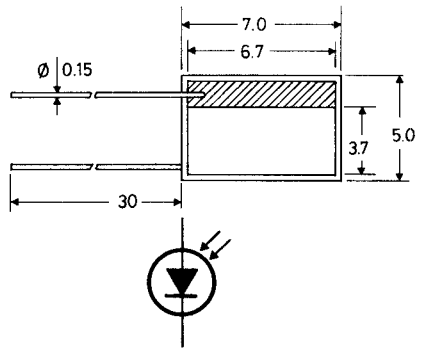

CK

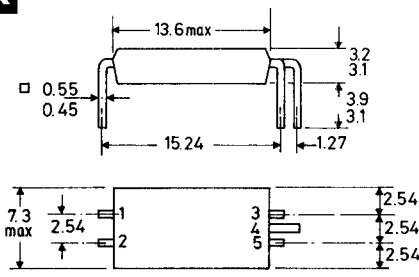

Pin	1	2	3	4	5
CK1	a	k	b	c	e
CK2	k	a	e	omitted	c

CL

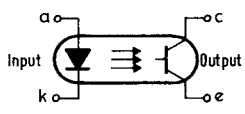
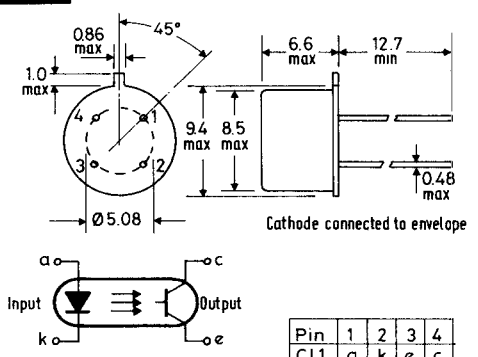

Pin	1	2	3	4
CL1	a	k	e	c
CL2	e	c	a	k

CM

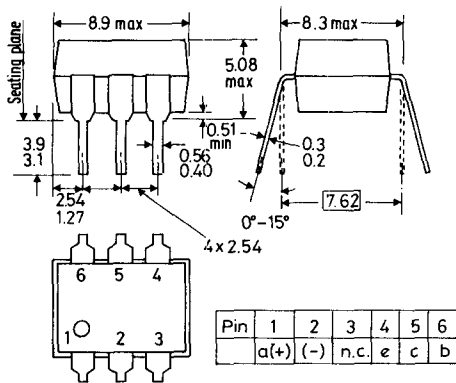

CN

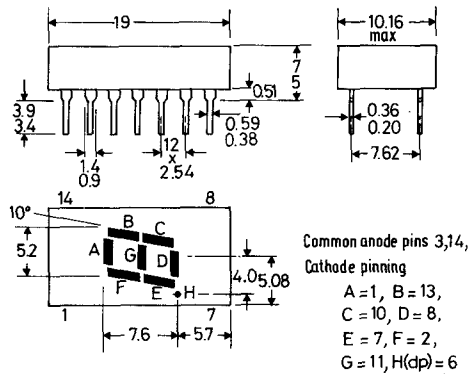

CO

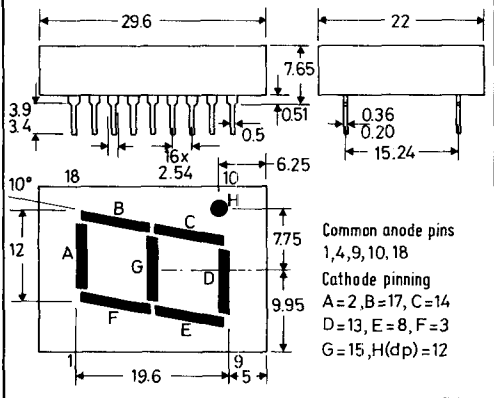

These drawings give limited information for quick reference purposes. For equipment design more complete information should be obtained from individual data sheets in the Technical Handbook or from standard B.S. or JEDEC outline drawings.