

4-BIT X 16-WORD FIFO REGISTER

FEATURES

- Independent asynchronous inputs and outputs
- Expandable in either direction
- Reset capability
- Status indicators on inputs and outputs
- 3-state outputs
- Output capability: standard
- I_{CC} category: MSI

GENERAL DESCRIPTION

The 74HC/HCT40105 are high-speed Si-gate CMOS devices and are pin compatible with the "40105" of the "4000B" series. They are specified in compliance with JEDEC standard no. 7A.

The 74HC/HCT40105 are first-in/first-out (FIFO) "elastic" storage registers that can store sixteen 4-bit words. The "40105" is capable of handling input and output data at different shifting rates. This feature makes it particularly useful as a buffer between asynchronous systems. Each word position in the register is clocked by a control flip-flop, which stores a marker bit. A "1" signifies that the position's data is filled and a "0" denotes a vacancy in that position. The control flip-flop detects the state of the preceding flip-flop and communicates its own status to the succeeding flip-flop. When a control flip-flop is in the "0" state and sees a "1" in the preceding flip-flop, it generates a clock pulse that transfers data from the preceding four data latches into its own four data latches and resets the preceding flip-flop to "0". The first and last control flip-flops have buffered outputs. Since all empty locations "bubble" automatically to the input end, and all valid data ripples through to the output end, the status of the first control flip-flop (data-in ready output - DIR) indicates if the FIFO is full, and the status of the last flip-flop (data-out ready output - DOR) indicates if the FIFO

(continued on next page)

SYMBOL	PARAMETER	CONDITIONS	TYPICAL		UNIT
			HC	HCT	
t _{PHL} / t _{PLH}	propagation delay MR to DIR, DOR S _O to Q _n	C _L = 15 pF V _{CC} = 5 V	16	15	ns
			37	35	ns
t _{PHL}	propagation delay SI to DIR S _O to DOR		16 17	18 18	ns ns
f _{max}	maximum clock frequency		33	31	MHz
C _I	input capacitance		3.5	3.5	pF
C _{PD}	power dissipation capacitance per package	notes 1 and 2	134	145	pF

GND = 0 V; T_{amb} = 25 °C; t_r = t_f = 6 ns

Notes

1. C_{PD} is used to determine the dynamic power dissipation (P_D in μW):

$$P_D = C_{PD} \times V_{CC}^2 \times f_i + \Sigma (C_L \times V_{CC}^2 \times f_o) \text{ where:}$$

f_i = input frequency in MHz
f_o = output frequency in MHz
Σ (C_L × V_{CC}² × f_o) = sum of outputs

C_L = output load capacitance in pF
V_{CC} = supply voltage in V

2. For HC the condition is V_I = GND to V_{CC}
For HCT the condition is V_I = GND to V_{CC} - 1.5 V

ORDERING INFORMATION/PACKAGE OUTLINES

PC74HC/HCT40105P: 16-lead DIL; plastic (SOT-38Z).

PC74HC/HCT40105T: 16-lead mini-pack; plastic (SO-16; SOT-109A).

PIN DESCRIPTION

PIN NO.	SYMBOL	NAME AND FUNCTION
1	OE	output enable input (active LOW)
2	DIR	data-in ready output.
3	SI	shift-in input (LOW-to-HIGH, edge-triggered)
4, 5, 6, 7	D ₀ to D ₃	parallel data inputs
8	GND	ground (0 V)
9	MR	asynchronous master reset input (active HIGH)
13, 12, 11, 10	Q ₀ to Q ₃	3-state data outputs
14	DOR	data-out ready output
15	S _O	shift-out input (HIGH-to-LOW, edge-triggered)
16	V _{CC}	positive supply voltage

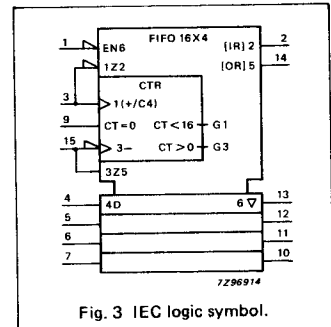
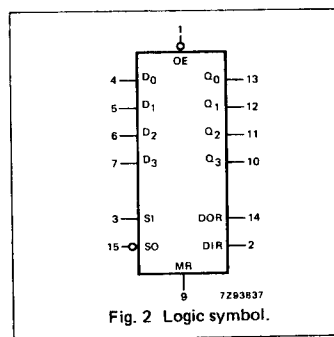
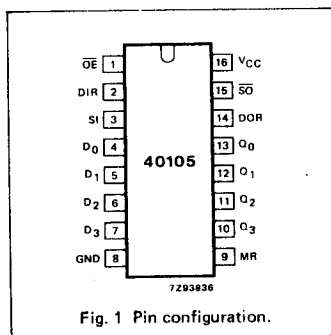

GENERAL DESCRIPTION (Cont'd)

contains data. As the earliest data is removed from the bottom of the data stack (output end), all data entered later will automatically ripple toward the output.

INPUTS AND OUTPUTS**Data inputs (D₀ to D₃)**

As there is no weighting of the inputs, any input can be assigned as the MSB. The size of the FIFO memory can be reduced from the 4 x 16 configuration, i.e. 3 x 16, down to 1 x 16, by tying unused data input pins to V_{CC} or GND.

Data outputs (Q₀ to Q₃)

As there is no weighting of the outputs, any output can be assigned as the MSB. The size of the FIFO memory can be reduced from the 4 x 16 configuration as described for data inputs. In a reduced format, the unused data output pins must be left open circuit.

Master-reset (MR)

When MR is HIGH, the control functions within the FIFO are cleared, and data content is declared invalid. The data-in-ready (DIR) flag is set HIGH and the data-out-ready (DOR) flag is set LOW. The output stage remains in the state of the last word that was shifted out, or in the random state existing at power-up.

Status flag outputs (DIR, DOR)

Indication of the status of the FIFO is given by two status flags, data-in-ready (DIR) and data-out-ready (DOR):

- DIR = HIGH indicates the input stage is empty and ready to accept valid data;
- DIR = LOW indicates that the FIFO is full or that a previous shift-in operation is not complete (busy);
- DOR = HIGH assures valid data is present at the outputs Q₀ to Q₃ (does not indicate that new data is awaiting transfer into the output stage);
- DOR = LOW indicates the output stage is busy or there is no valid data.

Shift-in control (SI)

Data is loaded into the input stage on a LOW-to-HIGH transition of SI. It also triggers an automatic data transfer process (ripple through). If SI is held HIGH during reset, data will be loaded at the falling edge of the MR signal.

Shift-out control (S_O)

A LOW-to-HIGH transition of S_O causes the DOR flags to go LOW. A HIGH-to-LOW transition of S_O causes

upstream data to move into the output stage, and empty locations to move towards the input stage (bubble-up).

Output enable (OE)

The outputs Q₀ to Q₃ are enabled when OE = LOW. When OE = HIGH the outputs are in the high impedance OFF-state.

FUNCTIONAL DESCRIPTION**Data input**

Following power-up, the master-reset (MR) input is pulsed HIGH to clear the FIFO memory (see Fig. 8). The data-in-ready flag (DIR = HIGH) indicates that the FIFO input stage is empty and ready to receive data. When DIR is valid (HIGH), data present at D₀ to D₃ can be shifted-in using the SI control input. With SI = HIGH, data is shifted into the input stage and a busy indication is given by DIR going LOW.

The data remains at the first location in the FIFO until DIR is set to HIGH and data moves through the FIFO to the output stage, or to the last empty location. If the FIFO is not full after the SI pulse, DIR again becomes valid (HIGH) to indicate that space is available in the FIFO. The DIR flag remains LOW if the FIFO is full (see Fig. 6). The SI pulse must be made LOW in order to complete the shift-in process.

With the FIFO full, SI can be held HIGH until a shift-out (S_O) pulse occurs. Then, following a shift-out of data, an empty location appears at the FIFO input and DIR goes HIGH to allow the next data to be shifted-in. This remains at the first FIFO location until SI goes LOW (see Fig. 7).

Data transfer

After data has been transferred from the input stage of the FIFO following SI = LOW, data moves through the FIFO asynchronously and is stacked at the output end of the register. Empty locations appear at the input end of the FIFO as data moves through the device.

Data output

The data-out-ready flag (DOR = HIGH) indicates that there is valid data at the output (Q₀ to Q₃). The initial master-reset at power-on (MR = HIGH) sets DOR to LOW (see Fig. 8). After MR = LOW, data shifted into the FIFO moves through to the output stage causing DOR to go HIGH. As the DOR flag goes HIGH, data can be shifted-out using the S_O control input. With S_O = HIGH, data in the output stage is shifted out and a busy indication is given by DOR going LOW. When S_O is made LOW, data moves through the FIFO

to fill the output stage and an empty location appears at the input stage. When the output stage is filled DOR goes HIGH, but if the last of the valid data has been shifted-out leaving the FIFO empty the DOR flag remains LOW (see Fig. 9). With the FIFO empty, the last word that was shifted-out is latched at the output Q₀ to Q₃.

With the FIFO empty, the S_O input can be held HIGH until the SI control input is used. Following an SI pulse, data moves through the FIFO to the output stage, resulting in the DOR flag pulsing HIGH and as shift-out of data occurring. The S_O control must be made LOW before additional data can be shifted-out (see Fig. 10).

High-speed burst mode

If it is assumed that the shift-in/shift-out pulses are not applied until the respective status flags are valid, it follows that the shift-in/shift-out rates are determined by the status flags. However, without the status flags a high-speed burst mode can be implemented. In this mode, the burst-in/burst-out rates are determined by the pulse widths of the shift-in/shift-out inputs and burst rates of 35 MHz can be obtained. Shift pulses can be applied without regard to the status flags but shift-in pulses that would overflow the storage capacity of the FIFO are not allowed (see Figs 11 and 12).

Expanded format

With the addition of a logic gate, the FIFO is easily expanded to increase word length (see Fig. 17). The basic operation and timing are identical to a single FIFO, with the exception of an additional gate delay on the flag outputs. If during application, the following occurs:

- SI is held HIGH when the FIFO is empty, some additional logic is required to produce a composite DIR pulse (see Figs 7 and 18).

Due to the part-to-part spread of the ripple through time, the SI signals of FIFO_A and FIFO_B will not always coincide and the AND-gate will not produce a composite flag signal. The solution is given in Fig. 18.

The "40105" is easily cascaded to increase the word capacity and no external components are needed. In the cascaded configuration, all necessary communications and timing are performed by the FIFOs. The intercommunication speed is determined by the minimum flag pulse widths and the flag delays. The data rate of cascaded devices is typically 25 MHz. Word-capacity can be expanded to and beyond 32-words x 4-bits (see Fig. 19).

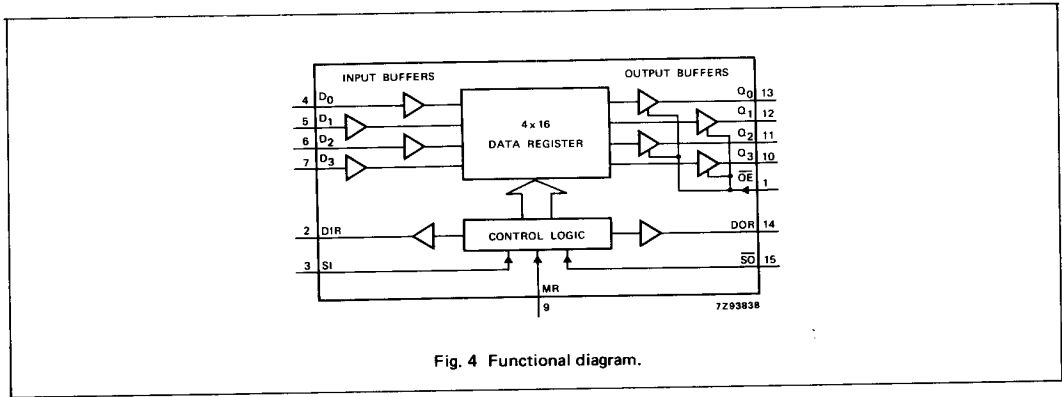

Fig. 4 Functional diagram.

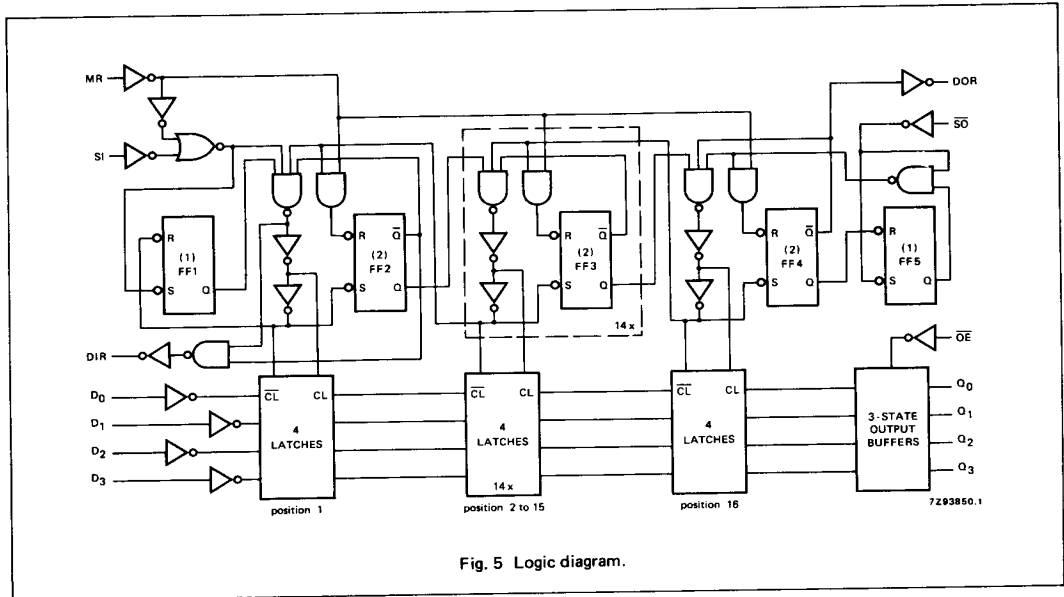

Fig. 5 Logic diagram.

Notes to Fig. 5

(see control flip-flops)

(1) LOW on \bar{S} input of FF1 and FF5 will set Q output to HIGH independent of state on \bar{R} input.

(2) LOW on \bar{R} input of FF2, FF3 and FF4 will set Q output to LOW independent of state on \bar{S} input.

DC CHARACTERISTICS FOR 74HC

For the DC characteristics see chapter "HCMOS family characteristics", section "Family specifications."

Output capability: standard

I_{CC} category: MSI**AC CHARACTERISTICS FOR 74HC**GND = 0 V; t_r = t_f = 6 ns; C_L = 50 pF

SYMBOL	PARAMETER	T _{amb} (°C)						UNIT	TEST CONDITIONS		
		74HC							V _{CC} V	WAVEFORMS	
		+25			-40 to +85		-40 to +125				
		min.	typ.	max.	min.	max.	min.				max.
t _{PHL} / t _{PLH}	propagation delay MR to DIR, DOR		52 19 15	175 35 30		220 44 37		265 53 45	ns	2.0 4.5 6.0	Fig. 8
t _{PHL}	propagation delay SI to DIR		52 19 15	210 42 36		265 53 45		315 63 54	ns	2.0 4.5 6.0	Fig. 6
t _{PHL}	propagation delay S \bar{O} to DOR		55 20 16	210 42 36		265 53 45		315 63 54	ns	2.0 4.5 6.0	Fig. 9
t _{PHL} / t _{PLH}	propagation delay S \bar{O} to Q _n		116 42 34	400 80 68		500 100 85		600 120 102	ns	2.0 4.5 6.0	Fig. 14
t _{PLH}	propagation delay/ ripple through delay SI to DOR		564 205 165	2000 400 340		2500 500 425		3000 600 510	ns	2.0 4.5 6.0	Fig. 10
t _{PLH}	propagation delay/ bubble-up delay S \bar{O} to DIR		701 255 204	2500 500 425		3125 625 532		3750 750 638	ns	2.0 4.5 6.0	Fig. 7
t _{PZH} / t _{PZL}	3-state output enable time OE to Q _n		41 15 12	150 30 26		190 38 33		225 45 38	ns	2.0 4.5 6.0	Fig. 16
t _{PHZ} / t _{PLZ}	3-state output disable time OE to Q _n		41 15 12	140 28 24		175 35 30		210 42 36	ns	2.0 4.5 6.0	Fig. 16
t _{THL} / t _{TLH}	output transition time		19 7 6	75 15 13		95 19 16		110 22 19	ns	2.0 4.5 6.0	Fig. 14
t _w	SI pulse width HIGH or LOW	80 16 14	19 7 6		100 20 17		120 24 20		ns	2.0 4.5 6.0	Fig. 6
t _w	S \bar{O} pulse width HIGH or LOW	120 24 20	39 14 11		150 30 26		180 36 31		ns	2.0 4.5 6.0	Fig. 9
t _w	DIR pulse width HIGH	12 6 5	58 21 17	180 36 31	10 5 4	225 45 38	10 5 4	270 54 46	ns	2.0 4.5 6.0	Fig. 7
t _w	DOR pulse width LOW	12 6 5	55 20 16	170 34 29	10 5 4	215 43 37	10 5 4	255 51 43	ns	2.0 4.5 6.0	Fig. 9

AC CHARACTERISTICS FOR 74HC (Cont'd)

SYMBOL	PARAMETER	T _{amb} (°C)						UNIT	TEST CONDITIONS	
		74HC							V _{CC} V	WAVEFORMS
		+25			-40 to +85		-40 to +125			
		min.	typ.	max.	min.	max.	min.			
t _w	MR pulse width HIGH	80 16 14	22 8 6		100 20 17		120 24 20	ns	2.0 4.5 6.0	Fig. 8
t _{rem}	removal time MR to SI	50 10 9	14 5 4		65 13 11		75 15 13	ns	2.0 4.5 6.0	Fig. 15
t _{su}	set-up time D _n to SI	-5 -5 -5	-39 -14 -11		-5 -5 -5		-5 -5 -5	ns	2.0 4.5 6.0	Fig. 13
t _h	hold time D _n to SI	125 25 21	44 16 13		155 31 26		190 38 32	ns	2.0 4.5 6.0	Fig. 13
f _{max}	maximum pulse frequency SI, SO using flags or burst mode	3.6 18 21	10 30 36		2.8 14 16		2.4 12 14	MHz	2.0 4.5 6.0	Figs 6, 9, 11 and 12
f _{max}	maximum pulse frequency SI, SO cascaded	3.6 18 21	10 30 36		2.8 14 16		2.4 12 14	MHz	2.0 4.5 6.0	Figs 6 and 9

DC CHARACTERISTICS FOR 74HCT

For the DC characteristics see chapter "HCMOS family characteristics", section "Family specifications".

Output capability: standard

I_{CC} category: MSI

Note to HCT types

The value of additional quiescent supply current (ΔI_{CC}) for a unit load of 1 is given in the family specifications. To determine ΔI_{CC} per input, multiply this value by the unit load coefficient shown in the table below.

INPUT	UNIT LOAD COEFFICIENT
OE	0.75
SI	0.40
D _n	0.30
MR	1.50
SO	0.40

AC CHARACTERISTICS FOR 74HCT

GND = 0 V; $t_r = t_f = 6$ ns; $C_L = 50$ pF

SYMBOL	PARAMETER	T_{amb} (°C)								UNIT	TEST CONDITIONS	
		74HCT									V_{CC} V	WAVEFORMS
		+25			-40 to +85		-40 to +125					
		min.	typ.	max.	min.	max.	min.	max.				
t_{PHL}/t_{PLH}	propagation delay MR to DIR, DOR		18	35		44		53	ns	4.5	Fig. 8	
t_{PHL}	propagation delay SI to DIR		21	42		53		63	ns	4.5	Fig. 6	
t_{PHL}	propagation delay SO to DOR		20	42		53		63	ns	4.5	Fig. 9	
t_{PHL}/t_{PLH}	propagation delay SO to Q_n		40	80		100		120	ns	4.5	Fig. 14	
t_{PLH}	propagation delay/ ripple through delay SI to DOR		188	400		500		600	ns	4.5	Fig. 10	
t_{PLH}	propagation delay/ bubble-up delay SO to DIR		244	500		625		750	ns	4.5	Fig. 7	
t_{pZH}/t_{pZL}	3-state output enable time OE to Q_n		18	35		44		53	ns	4.5	Fig. 16	
t_{pHZ}/t_{pLZ}	3-state output disable time OE to Q_n		15	30		38		45	ns	4.5	Fig. 16	
t_{THL}/t_{TLH}	output transition time		7	15		19		22	ns	4.5	Fig. 14	
t_W	SI pulse width HIGH or LOW	16	6		20		24		ns	4.5	Fig. 6	
t_W	SO pulse width HIGH or LOW	16	7		20		24		ns	4.5	Fig. 9	
t_W	DIR pulse width HIGH or LOW	6	20	34	5	43	5	51	ns	4.5	Fig. 7	
t_W	DOR pulse width HIGH or LOW	6	19	34	5	43	5	51	ns	4.5	Fig. 9	
t_W	MR pulse width HIGH	16	7		20		24		ns	4.5	Fig. 8	
t_{rem}	removal time MR to SI	15	7		19		22		ns	4.5	Fig. 15	
t_{su}	set-up time D_n to SI	-5	-14		-5		-5		ns	4.5	Fig. 13	
t_h	hold time D_n to SI	25	16		31		38		ns	4.5	Fig. 13	
f_{max}	maximum pulse frequency SI, SO using flags or burst mode	15	28		12		10		MHz	4.5	Figs 6, 9, 11 and 12	
f_{max}	maximum pulse frequency SI, SO cascaded	15	28		12		10		MHz	4.5	Figs 6 and 9	

AC WAVEFORMS

Shifting in sequence FIFO empty to FIFO full

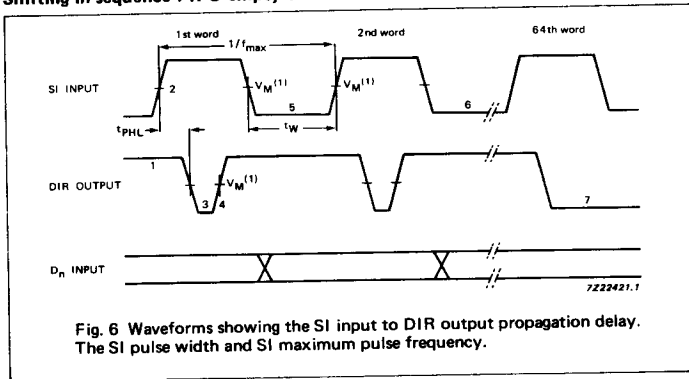

Fig. 6 Waveforms showing the SI input to DIR output propagation delay. The SI pulse width and SI maximum pulse frequency.

Notes to Fig. 6

1. DIR initially HIGH; FIFO is prepared for valid data.
2. SI set HIGH; data loaded into input stage.
3. DIR drops LOW, input stage "busy".
4. DIR goes HIGH, status flag indicates FIFO prepared for additional data; data from first location "ripple through".
5. SI set LOW; necessary to complete shift-in process.
6. Repeat process to load 2nd word through to 16th word into FIFO.
7. DIR remains LOW; with attempt to shift into full FIFO, no data transfer occurs.

With FIFO full; SI held HIGH in anticipation of empty location

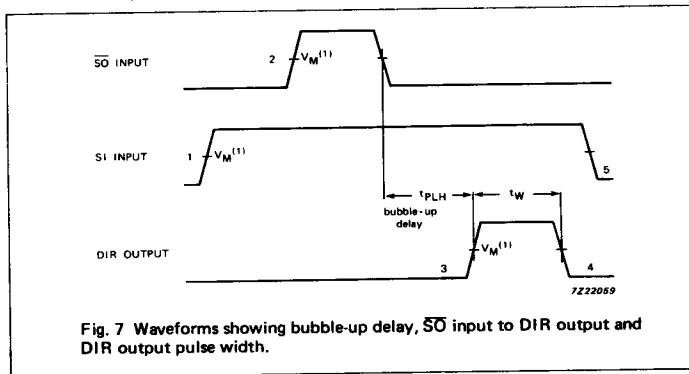

Fig. 7 Waveforms showing bubble-up delay, SO input to DIR output and DIR output pulse width.

Notes to Fig. 7

1. FIFO is initially, shift-in is held HIGH.
2. SO pulse; data in the output stage is unloaded, "bubble-up process of empty locations begins".
3. DIR HIGH; when empty location reached input stage, flag indicates FIFO is prepared for data input.
4. DIR returns to LOW; FIFO is full again.
5. SI brought LOW; necessary to complete shift-in process, DIR remains LOW, because FIFO is full.

AC WAVEFORMS (Cont'd)

Master reset applied with FIFO full

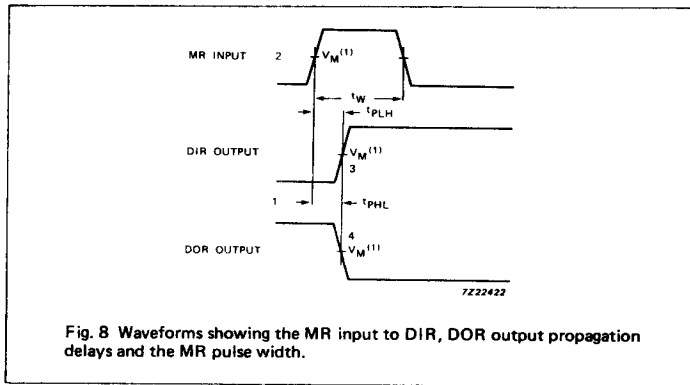

Notes to Fig. 8

1. DIR LOW, output ready HIGH; assume FIFO is full.
2. MR pulse HIGH; clears FIFO.
3. DIR goes HIGH; flag indicates input prepared for valid data.
4. DOR drops LOW; flag indicates FIFO empty.

Shifting out sequence; FIFO full to FIFO empty

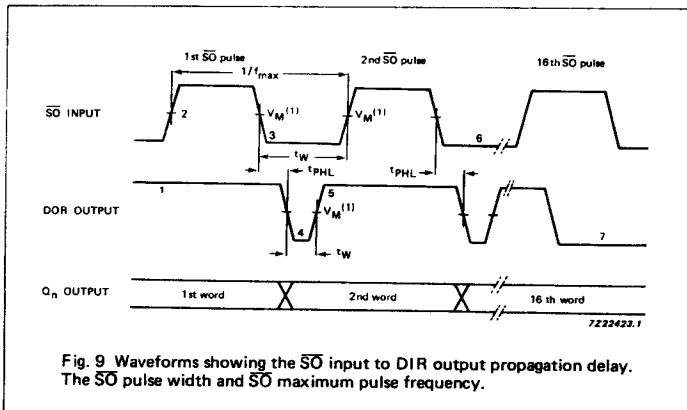

Notes to Fig. 9

1. DOR HIGH; no data transfer in progress, valid data is present at output stage.
2. $\overline{S_O}$ set HIGH.
3. $\overline{S_O}$ is set LOW; data in the input stage is unloaded, and new data replaces it as empty location "bubbles-up" to input stage.
4. DOR drops LOW; output stage "busy".
5. DOR goes HIGH; transfer process completed, valid data present at output after the specified propagation delay.
6. Repeat process to unload the 3rd through to the 16th word from FIFO.
7. DOR remains LOW; FIFO is empty.

With FIFO empty; $\overline{S\bar{O}}$ is held HIGH in anticipation

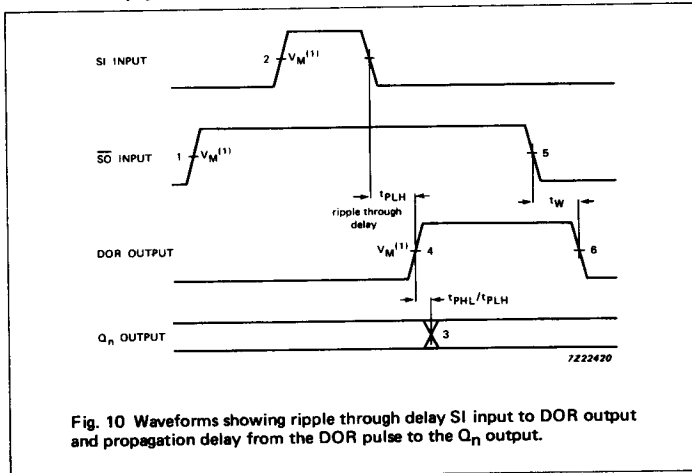

Fig. 10 Waveforms showing ripple through delay SI input to DOR output and propagation delay from the DOR pulse to the Q_n output.

Notes to Fig. 10

1. FIFO is initially empty, $\overline{S\bar{O}}$ is held HIGH.
2. SI pulse; loads data into FIFO and initiates ripple through process.
3. DOR flag signals the arrival of valid data at the output stage.
4. Output transition; data arrives at output stage after the specified propagation delay between the rising edge of the DOR pulse to the Q_n output.
5. $\overline{S\bar{O}}$ set LOW; necessary to complete shift-out process. DOR remains LOW, because FIFO is empty.
6. DOR goes LOW; FIFO is empty again.

Shift-in operation; high-speed burst mode

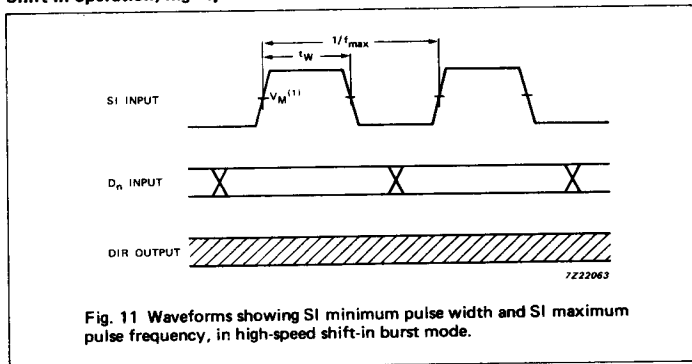

Fig. 11 Waveforms showing SI minimum pulse width and SI maximum pulse frequency, in high-speed shift-in burst mode.

Note to Fig. 11

In the high-speed mode, the burst-in rate is determined by the minimum shift-in HIGH and shift-in LOW specifications. The DIR status flag is a don't care condition, and a shift-in pulse can be applied regardless of the flag. A SI pulse which would overflow the storage capacity of the FIFO is ignored.

AC WAVEFORMS (Cont'd)

Shift-out operation; high-speed burst mode

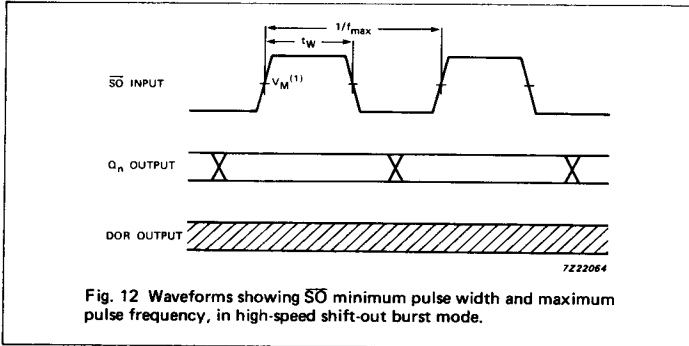

Fig. 12 Waveforms showing \overline{SO} minimum pulse width and maximum pulse frequency, in high-speed shift-out burst mode.

Note to Fig. 12

In the high-speed mode, the burst-out rate is determined by the minimum shift-out HIGH and shift-out LOW specifications. The DOR flag is a don't care condition and a \overline{SO} pulse can be applied without regard to the flag.

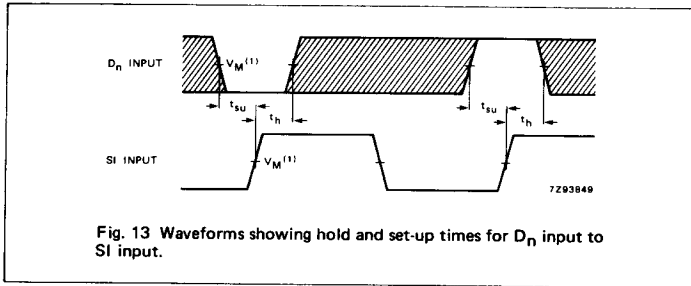

Fig. 13 Waveforms showing hold and set-up times for D_n input to S_i input.

Note to Fig. 13

The shaded areas indicate when the input is permitted to change for predictable output performance.

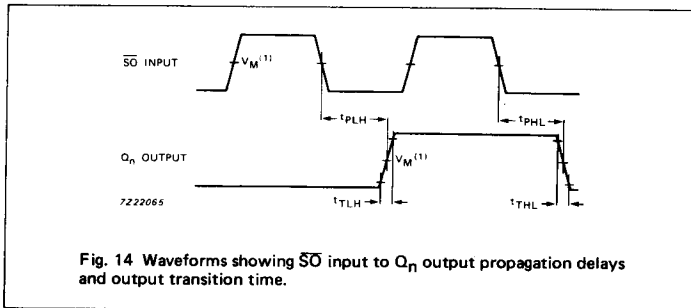
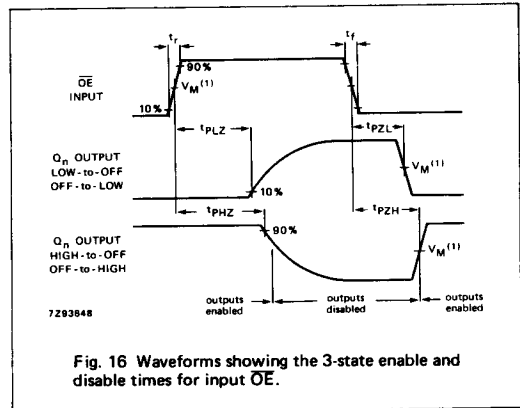
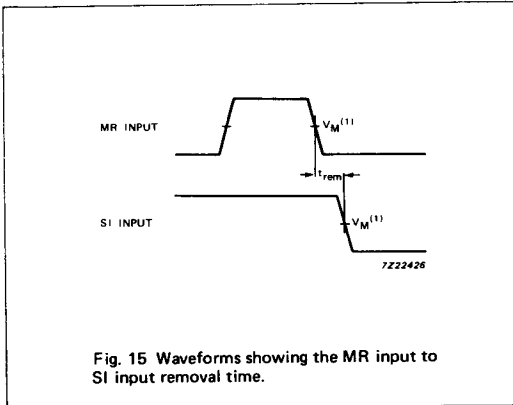

Fig. 14 Waveforms showing \overline{SO} input to Q_n output propagation delays and output transition time.



Note to AC waveforms

(1) HC : $V_M = 50\%$; $V_I = GND$ to V_{CC} .
HCT: $V_M = 1.3V$; $V_I = GND$ to $3V$.

APPLICATION INFORMATION

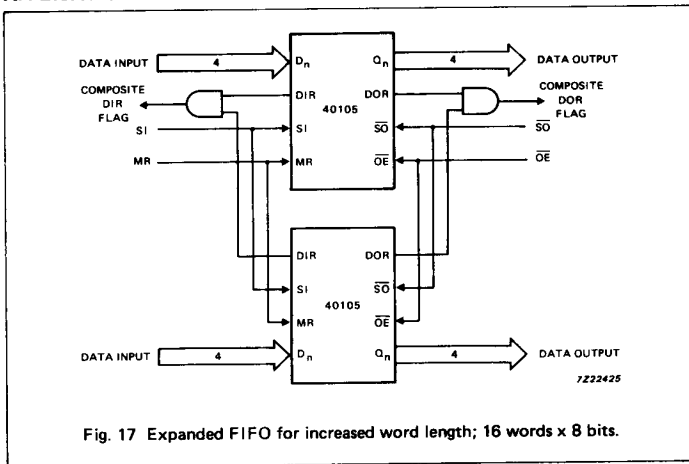

Note to Fig. 17

The PC74HC/HCT40105 is easily expanded to increase word length. Composite DIR and DOR flags are formed with the addition of an AND gate. The basic operation and timing are identical to a single FIFO, with the exception of an added gate delay on the flags.

APPLICATION INFORMATION (Cont'd)

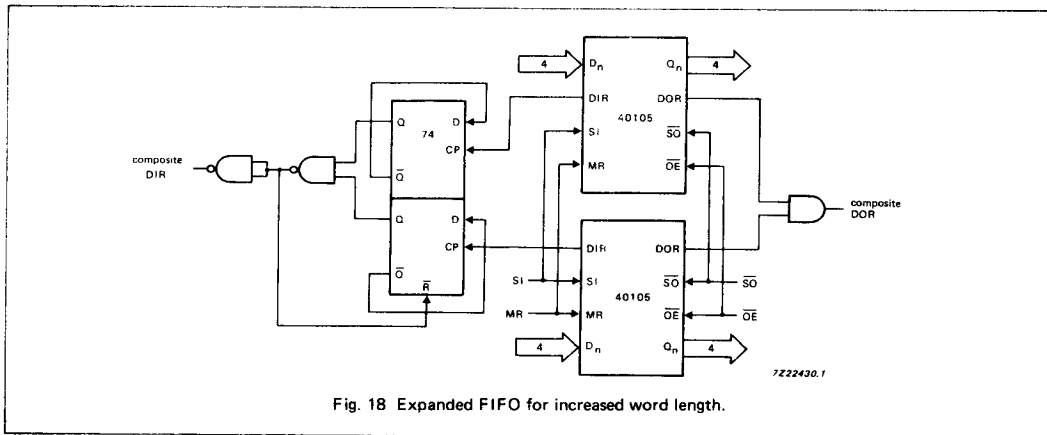

Fig. 18 Expanded FIFO for increased word length.

Note to Fig. 18

This circuit is only required if the SI input is constantly held HIGH, when the FIFO is empty and the automatic shift-in cycles are started (see Fig. 7).

Expanded format

Fig. 19 shows two cascaded FIFOs providing a capacity of 32 words x 4 bits.

Fig. 20 shows the signals on the nodes of both FIFOs after the application of a SI pulse, when both FIFOs are initially empty. After a rippled through delay, data arrives at the output of FIFO_A. Due to \overline{SO}_A being HIGH, a DOR pulse is generated. The requirements of SI_B and D_{nB} are satisfied by the DOR_A pulse width and the timing between the rising edge of DOR_A and Q_{nA} . After a second ripple through delay, data arrives at the output of FIFO_B.

Fig. 21 shows the signals on the nodes of both FIFOs after the application of a \overline{SO}_B pulse, when both FIFOs are initially full. After a bubble-up delay a DIR_B pulse is generated, which acts as a \overline{SO}_A pulse for FIFO_A. One word is transferred from the output of FIFO_A to the input of FIFO_B. The requirements of the \overline{SO}_A pulse for FIFO_A is satisfied by the pulse width of DOR_B. After a second bubble-up delay an empty space arrives at D_{nA} , at which time DIR_A goes HIGH.

Fig. 22 shows the waveforms at all external nodes of both FIFOs during a complete shift-in and shift-out sequence.

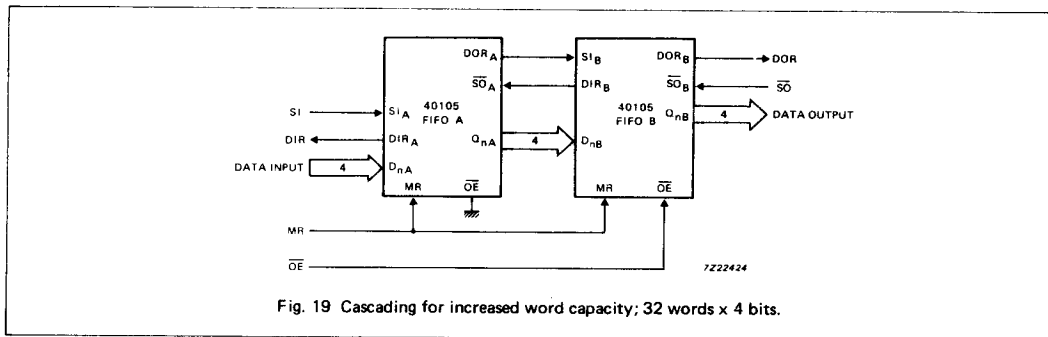

Fig. 19 Cascading for increased word capacity; 32 words x 4 bits.

Note to Fig. 19

The PC74HC/HCT40105 is easily cascaded to increase word capacity without any external circuitry. In cascaded format, all necessary communications are handled by the FIFOs. Figs 17 and 19 demonstrate the intercommunication timing between FIFO_A and FIFO_B. Fig. 22 gives an overview of pulses and timing of two cascaded FIFOs, when shifted full and shifted empty again.

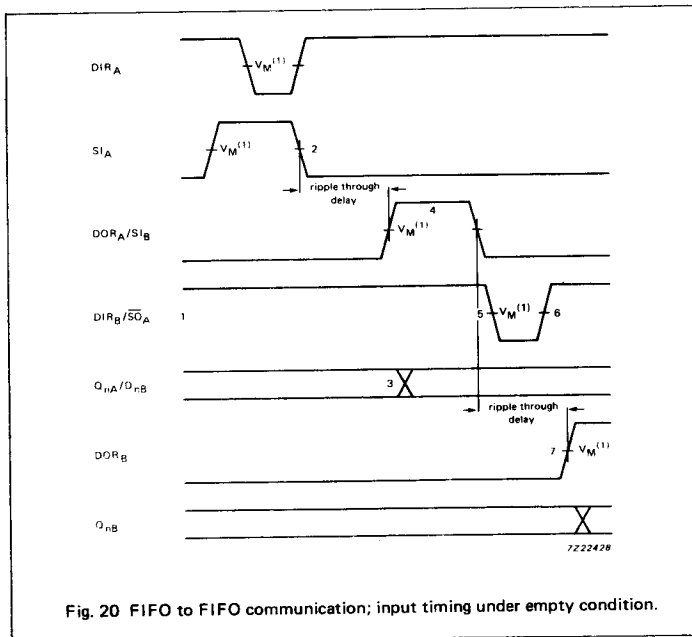

Fig. 20 FIFO to FIFO communication; input timing under empty condition.

Notes to Fig. 20

1. FIFO_A and FIFO_B initially empty, \overline{SO}_A held HIGH in anticipation of data.
2. Load one word into FIFO_A; SI pulse applied, results in DIR pulse.
3. Data out A/data in B transition; valid data arrives at FIFO_A output stage after a specified delay of the DOR flag, meeting data input set-up requirements of FIFO_B.
4. DOR_A and SI_B pulse HIGH; (ripple through delay after SI_A LOW) data is unloaded from FIFO_A as a result of the data output ready pulse, data is shifted into FIFO_B.
5. DIR_B and \overline{SO}_A go LOW; flag indicates input stage of FIFO_B is busy, shift-out of FIFO_A is complete.
6. DIR_B and \overline{SO}_A go HIGH automatically; the input stage of FIFO_B is again able to receive data, \overline{SO} is held HIGH in anticipation of additional data.
7. DOR_B goes HIGH; (ripple through delay after SI_B LOW) valid data is present one propagation delay later at the FIFO_B output stage.

APPLICATION INFORMATION (Cont'd)

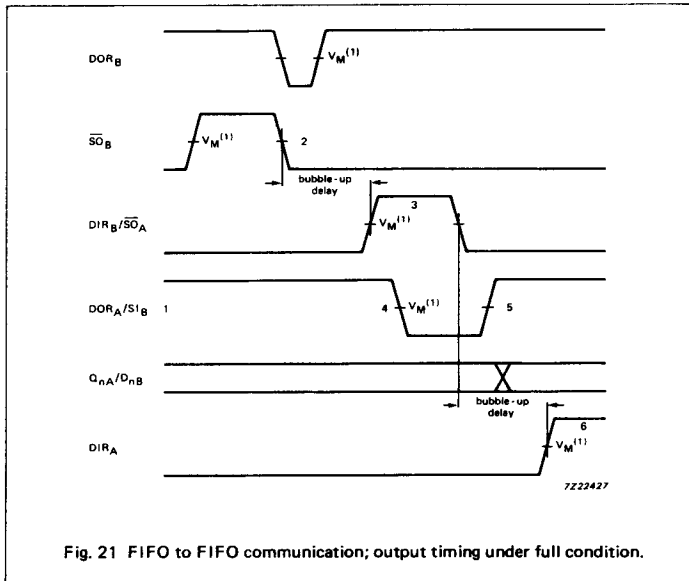

Fig. 21 FIFO to FIFO communication; output timing under full condition.

Notes to Fig. 21

1. FIFO_A and FIFO_B initially full, S_I_B held HIGH in anticipation of shifting in new data as empty location bubbles-up.
2. Unload one word from FIFO_B; S_O pulse applied, results in DOR pulse.
3. DIR_B and S_O_A pulse HIGH; (bubble-up delay after S_O_B LOW) data is loaded into FIFO_B as a result of the DIR pulse, data is shifted out of FIFO_A.
4. DOR_A and S_I_B go LOW; flag indicates the output stage of FIFO_A is busy, shift-in to FIFO_B is complete.
5. DOR_A and S_I_B go HIGH; flag indicates valid data is again available at FIFO_A output stage, S_I_B is held HIGH, awaiting bubble-up of empty location.
6. DIR_A goes HIGH; (bubble-up delay after S_O_A LOW) an empty location is present at input stage of FIFO_A.

Note to application waveforms

- (1) HC : $V_M = 50\%$; $V_I = \text{GND to } V_{CC}$.
 HCT: $V_M = 1.3 \text{ V}$; $V_I = \text{GND to } 3 \text{ V}$.

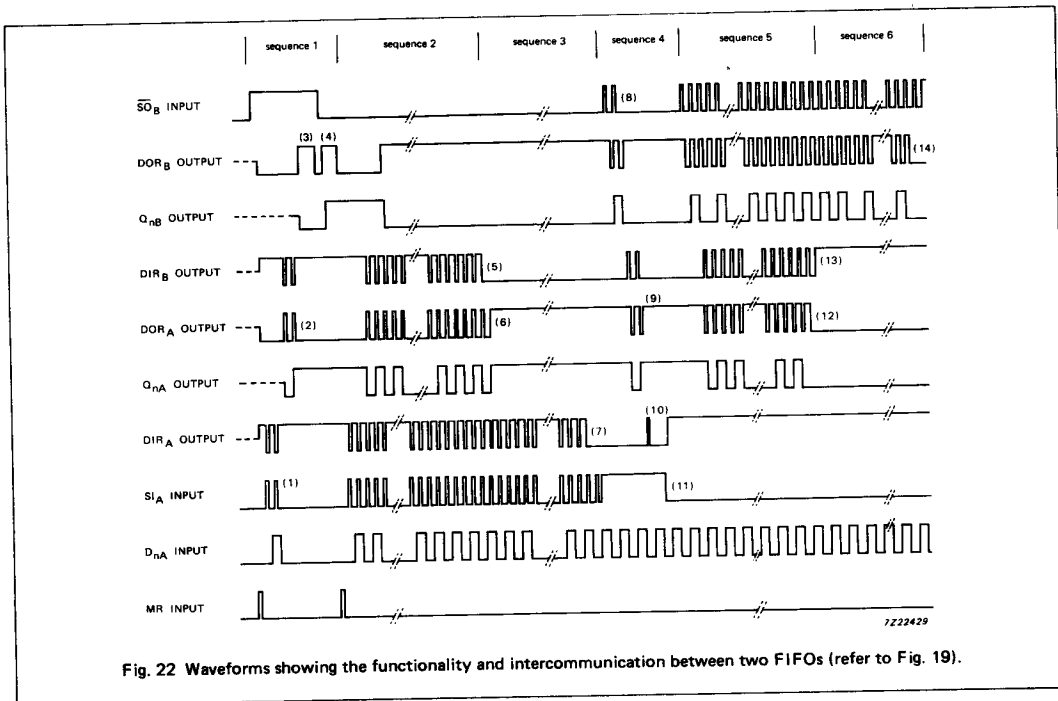

Fig. 22 Waveforms showing the functionality and intercommunication between two FIFOs (refer to Fig. 19).

Note to Fig. 22

Sequence 1 (Both FIFOs empty, starting shift-in process):

After a MR pulse has been applied $FIFO_A$ and $FIFO_B$ are empty. The DOR flags of $FIFO_A$ and $FIFO_B$ go LOW due to no valid data being present at the outputs. The DIR flags are set HIGH due to the FIFOs being ready to accept data. \overline{SO}_B is held HIGH and two SI_A pulses are applied (1). These pulses allow two data words to ripple through to the output stage of $FIFO_A$ and to the input stage of $FIFO_B$ (2). When data arrives at the output of $FIFO_B$, a DOR_B pulse is generated (3). When \overline{SO}_B goes LOW, the first bit is shifted out and a second bit ripples through to the output after which DOR_B goes HIGH (4).

Sequence 2 ($FIFO_B$ runs full):

After the MR pulse, a series of 16 SI pulses are applied. When 16 words are shifted in, DIR_B remains LOW due to $FIFO_B$ being full (5). DOR_A goes LOW due to $FIFO_A$ being empty.

Sequence 3 ($FIFO_A$ runs full):

When 17 words are shifted in, DOR_A remains HIGH due to valid data remaining at the output of $FIFO_A$. Q_{nA} remains HIGH, being the polarity of the 17th data word (6). After the 32th SI pulse, DIR remains LOW and both FIFOs are full (7). Additional pulses have no effect.

Sequence 4 (Both FIFOs full, starting shift-out process):

SI_A is held HIGH and two \overline{SO}_B pulses are applied (8). These pulses shift out two words and thus allow two empty locations to bubble-up to the input stage of $FIFO_B$, and proceed to $FIFO_A$ (9). When the first empty location arrives at the input of $FIFO_A$, a DIR_A pulse is generated (10) and a new word is shifted into $FIFO_A$. SI_A is made LOW and now the second empty location reaches the input stage of $FIFO_A$, after which DIR_A remains HIGH (11).

Sequence 5 ($FIFO_A$ runs empty):

At the start of sequence 5 $FIFO_A$ contains 15 valid words due to two words being shifted out and one word being shifted in in sequence 4. An additional series of \overline{SO}_B pulses are applied. After 15 \overline{SO}_B pulses, all words from $FIFO_A$ are shifted into $FIFO_B$. DOR_A remains LOW (12).

Sequence 6 ($FIFO_B$ runs empty):

After the next \overline{SO}_B pulse, DIR_B remains HIGH due to the input stage of $FIFO_B$ being empty (13). After another 15 \overline{SO}_B pulses, DOR_B remains LOW due to both FIFOs being empty (14). Additional \overline{SO}_B pulses have no effect. The last word remains available at the output Q_n .