

74F381 4-Bit Arithmetic Logic Unit

General Description

The 'F381 performs three arithmetic and three logic operations on two 4-bit words, A and B. Two additional select input codes force the function outputs LOW or HIGH. Carry propagate and generate outputs are provided for use with the 'F182 carry lookahead generator for high-speed expansion to longer word lengths. For ripple expansion, refer to the 'F382 ALU data sheet.

Features

- Low input loading minimizes drive requirements
- Performs six arithmetic and logic functions
- Selectable LOW (clear) and HIGH (preset) functions
- Carry generate and propagate outputs for use with carry lookahead generator

Commercial	Package Number	Package Description
74F381PC	N20A	20-Lead (0.300" Wide) Molded Dual-In-Line
74F381SC (Note 1)	M20B	20-Lead (0.300" Wide) Molded Small Outline, JEDEC
74F381SJ (Note 1)	M20D	20-Lead (0.300" Wide) Molded Small Outline, EIAJ

Note 1: Devices also available in 13" reel. Use suffix = SCX and SJX.

Logic Symbols

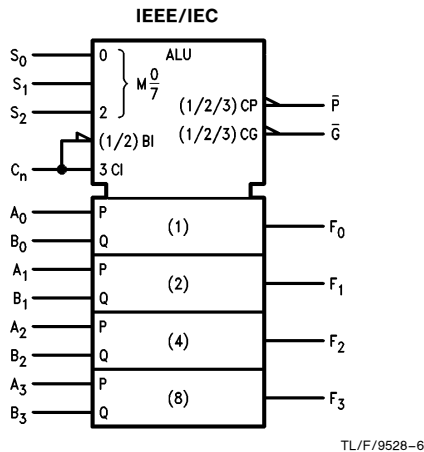
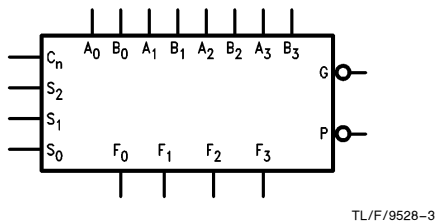

Connection Diagram

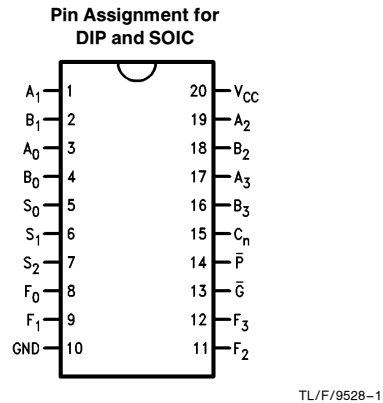

Unit Loading/Fan Out

Pin Names	Description	74F	
		U.L. HIGH/LOW	Input I_{IH}/I_{IL} Output I_{OH}/I_{OL}
A ₀ -A ₃	A Operand Inputs	1.0/3.0	20 μ A/ -1.8 mA
B ₀ -B ₃	B Operand Inputs	1.0/3.0	20 μ A/ -1.8 mA
S ₀ -S ₂	Function Select Inputs	1.0/1.0	20 μ A/ -0.6 mA
C _n	Carry Input	1.0/4.0	20 μ A/ -2.4 mA
\overline{G}	Carry Generate Output (Active LOW)	50/33.3	-1 mA/20 mA
\overline{P}	Carry Propagate Output (Active LOW)	50/33.3	-1 mA/20 mA
F ₀ -F ₃	Function Outputs	50/33.3	-1 mA/20 mA

Functional Description

Signals applied to the Select inputs S₀-S₂ determine the mode of operation, as indicated in the Function Select Table. An extensive listing of input and output levels is shown in the Truth Table. The circuit performs the arithmetic functions for either active HIGH or active LOW operands, with output levels in the same convention. In the Subtract operating modes, it is necessary to force a carry (HIGH for active

HIGH operands, LOW for active LOW operands) into the C_n input of the least significant package.

The Carry Generate (\overline{G}) and Carry Propagate (\overline{P}) outputs supply input signals to the 'F182 carry lookahead generator for expansion to longer word length, as shown in Figure 1. Note that an 'F382 ALU is used for the most significant package. Typical delays for Figure 1 are given in Figure 2.

Function Select Table

Select			Operation
S ₀	S ₁	S ₂	
L	L	L	Clear
H	L	L	B Minus A
L	H	L	A Minus B
H	H	L	A Plus B
L	L	H	A ⊕ B
H	L	H	A + B
L	H	H	AB
H	H	H	Preset

H = HIGH Voltage Level
L = LOW Voltage Level

FIGURE 2. 16-Bit Delay Tabulation

Path Segment	Toward F	Output C _n + 4, OVR
A _i or B _i to \overline{P}	7.2 ns	7.2 ns
\overline{P}_i to C _n + ('F182)	6.2 ns	6.2 ns
C _n to F	8.1 ns	—
C _n or C _n + 4, OVR	—	8.0 ns
Total Delay	21.5 ns	21.4 ns

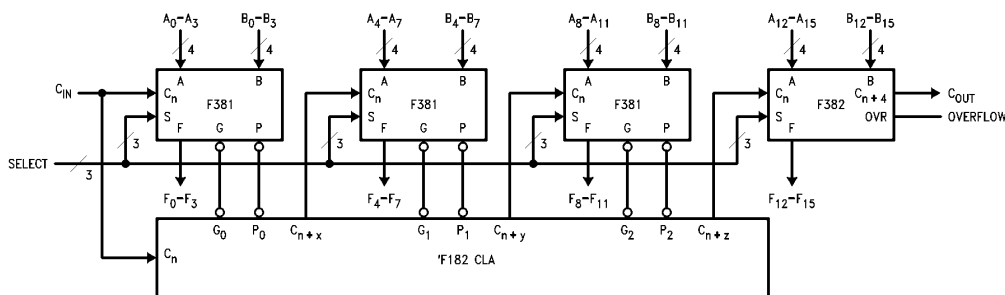
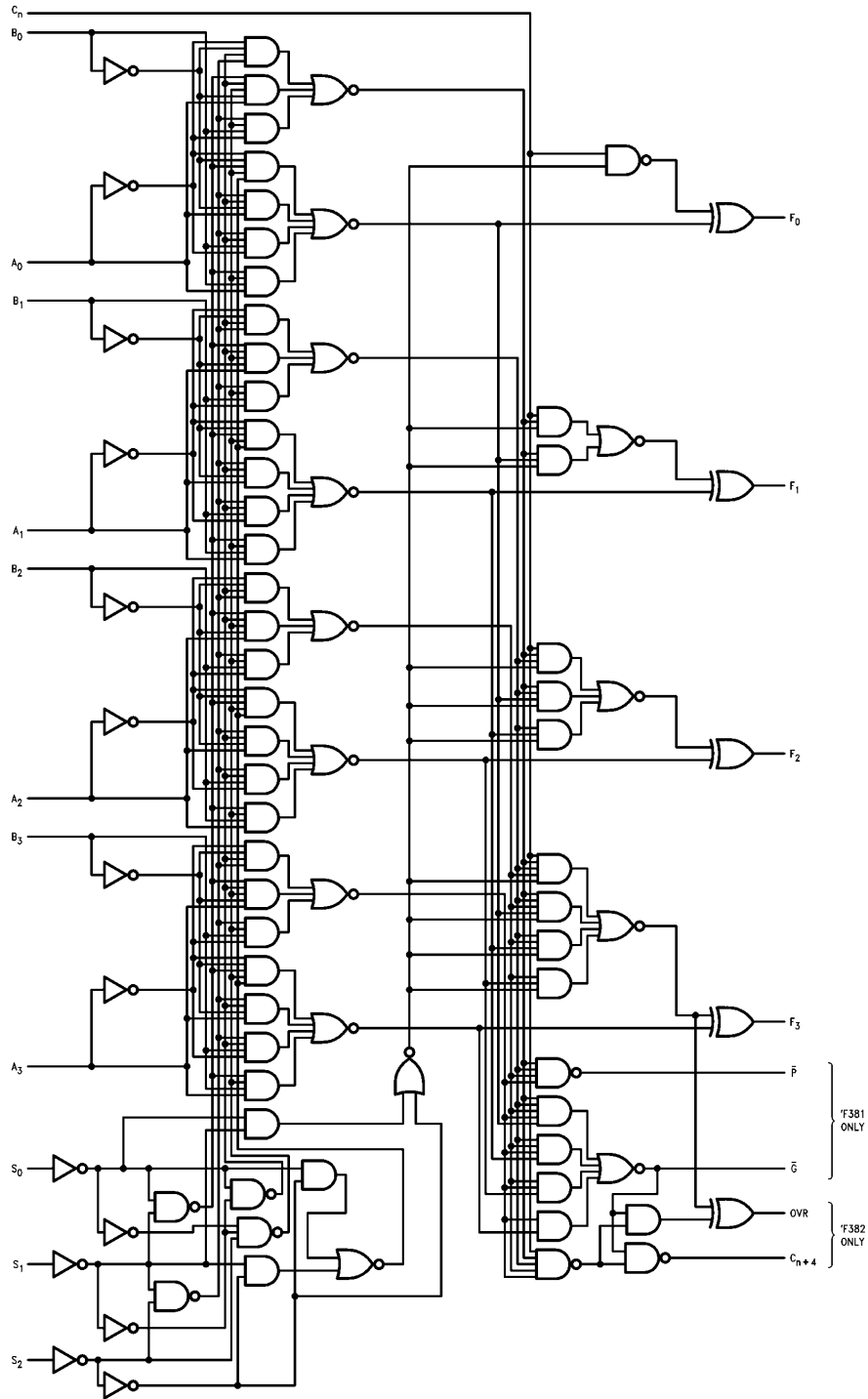

FIGURE 1. 16-Bit Lookahead Carry ALU Expansion

TL/F/9528-4

Logic Diagram



TL/F/9528-5

Please note that this diagram is provided only for the understanding of logic operations and should not be used to estimate propagation delays.

Truth Table

Function	Inputs						Outputs						
	S ₀	S ₁	S ₂	C _n	A _n	B _n	F ₀	F ₁	F ₂	F ₃	\bar{G}	\bar{P}	
CLEAR	L	L	L	X	X	X	L	L	L	L	L	L	
B Minus A	H	L	L	L	L	L	H	H	H	H	H	L	
				L	L	H	L	H	H	H	L	L	
				L	H	L	L	L	L	H	H	L	L
				L	H	H	L	L	L	H	H	L	L
				H	L	L	L	L	L	L	L	L	L
				H	L	H	L	L	L	H	H	L	L
				H	H	L	L	L	L	H	L	L	L
				H	H	H	L	L	L	L	L	L	L
A Minus B	L	H	L	L	L	L	H	H	H	H	H	L	
				L	L	H	L	L	L	L	L	H	L
				L	H	L	L	L	L	H	H	L	L
				L	H	H	L	L	L	H	H	L	L
				H	L	L	L	L	L	L	L	L	L
				H	L	H	L	L	L	H	L	L	L
				H	H	L	L	L	L	H	H	L	L
				H	H	H	L	L	L	L	L	L	L
A Plus B	H	H	L	L	L	L	H	L	L	L	L	H	
				L	L	H	L	H	H	H	H	L	L
				L	H	L	L	L	L	H	H	L	L
				L	H	H	L	L	L	L	L	L	L
				H	L	L	L	L	L	L	L	L	L
				H	L	H	L	L	L	L	L	L	L
				H	H	L	L	L	L	L	L	L	L
				H	H	H	L	L	L	H	H	L	L
A ⊕ B	L	L	H	X	L	L	L	L	L	L	L	H	
				X	L	H	L	H	H	H	H	L	
				X	H	L	L	H	H	L	L	L	
				X	H	H	L	L	L	L	L	L	
A + B	H	L	H	X	L	L	L	L	L	L	L	H	
				X	L	H	L	H	H	H	H	L	
				X	H	L	L	H	H	L	L	L	
				X	H	H	L	H	H	L	L	L	
AB	L	H	H	X	L	L	L	L	L	L	L	L	
				X	L	H	L	L	L	L	L	L	
				X	H	L	L	L	L	L	L	L	
				X	H	H	L	H	H	L	L	L	
PRESET	H	H	H	X	L	L	L	H	H	H	H	H	
				X	L	H	L	H	H	H	H	L	
				X	H	L	L	H	H	L	L	L	
				X	H	H	L	H	H	L	L	L	

H = HIGH Voltage Level
L = LOW Voltage Level
X = Immaterial

Absolute Maximum Ratings (Note 1)

Storage Temperature	-65°C to +150°C
Ambient Temperature under Bias	-55°C to +125°C
Junction Temperature under Bias	-55°C to +175°C
Plastic	-55°C to +150°C
V _{CC} Pin Potential to Ground Pin	-0.5V to +7.0V
Input Voltage (Note 2)	-0.5V to +7.0V
Input Current (Note 2)	-30 mA to +5.0 mA
Voltage Applied to Output in HIGH State (with V _{CC} = 0V)	
Standard Output	-0.5V to V _{CC}
TRI-STATE® Output	-0.5V to +5.5V
Current Applied to Output in LOW State (Max)	twice the rated I _{OL} (mA)

Note 1: Absolute maximum ratings are values beyond which the device may be damaged or have its useful life impaired. Functional operation under these conditions is not implied.

Note 2: Either voltage limit or current limit is sufficient to protect inputs.

Recommended Operating Conditions

Free Air Ambient Temperature	0°C to +70°C
Commercial	
Supply Voltage	+4.5V to +5.5V
Commercial	

DC Electrical Characteristics

Symbol	Parameter	74F			Units	V _{CC}	Conditions
		Min	Typ	Max			
V _{IH}	Input HIGH Voltage	2.0			V		Recognized as a HIGH Signal
V _{IL}	Input LOW Voltage			0.8	V		Recognized as a LOW Signal
V _{CD}	Input Clamp Diode Voltage			-1.2	V	Min	I _{IN} = -18 mA
V _{OH}	Output HIGH Voltage	74F 10% V _{CC} 74F 5% V _{CC}	2.5 2.7		V	Min	I _{OH} = -1 mA I _{OH} = -1 mA
V _{OL}	Output LOW Voltage	74F 10% V _{CC}		0.5	V	Min	I _{OL} = 20 mA
I _{IH}	Input HIGH Current	74F		5.0	μA		V _{IN} = 2.7V
I _{BVI}	Input HIGH Current Breakdown Test	74F		7.0	μA	Max	V _{IN} = 7.0V
I _{CEX}	Output HIGH Leakage Current	74F		50	μA	Max	V _{OUT} = V _{CC}
V _{ID}	Input Leakage Test	74F	4.75		V	0.0	I _{ID} = 1.9 μA All Other Pins Grounded
I _{OD}	Output Leakage Circuit Current	74F		3.75	μA	0.0	V _{IOD} = 150 mV All Other Pins Grounded
I _{IL}	Input LOW Current			-0.6 -1.8 -2.4	mA	Max Max Max	V _{IN} = 0.5V (S _n) V _{IN} = 0.5V (A _n , B _n) V _{IN} = 0.5V (C _n)
I _{OS}	Output Short-Circuit Current		-60	-150	mA	Max	V _{OUT} = 0V
I _{CC}	Power Supply Current		59	89	mA	Max	

AC Electrical Characteristics

Symbol	Parameter	74F			74F		Units
		$T_A = +25^\circ\text{C}$ $V_{CC} = +5.0\text{V}$ $C_L = 50\text{ pF}$			$T_A, V_{CC} = \text{Com}$ $C_L = 50\text{ pF}$		
		Min	Typ	Max	Min	Max	
t_{PLH} t_{PHL}	Propagation Delay C_n to F_i	2.5 2.5	8.1 5.7	12.0 8.0	2.5 2.5	13.0 9.0	ns
t_{PLH} t_{PHL}	Propagation Delay Any A or B to Any F	4.0 3.5	10.4 8.2	15.0 11.0	4.0 3.5	16.0 12.0	ns
t_{PLH} t_{PHL}	Propagation Delay S_i to F_i	4.5 4.0	8.3 8.2	20.5 15.0	4.5 4.0	21.5 16.0	ns
t_{PLH} t_{PHL}	Propagation Delay A_i or B_i to \bar{G}	3.5 3.5	6.4 6.8	10.0 10.0	3.5 3.0	11.0 11.0	ns
t_{PLH} t_{PHL}	Propagation Delay A_i or B_i to \bar{P}	2.5 3.5	7.2 6.5	10.5 9.5	2.5 3.5	11.5 10.5	ns
t_{PLH} t_{PHL}	Propagation Delay S_i to \bar{G} or \bar{P}	4.0 4.5	7.8 10.2	12.0 13.5	4.0 4.5	13.0 14.5	ns

Ordering Information

The device number is used to form part of a simplified purchasing code where the package type and temperature range are defined as follows:

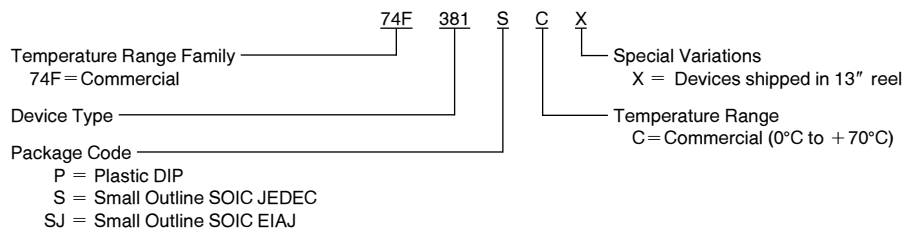

Physical Dimensions inches (millimeters)

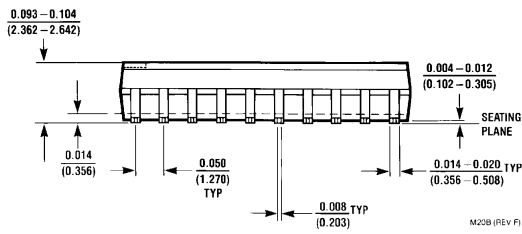
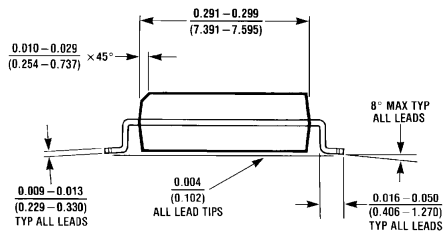
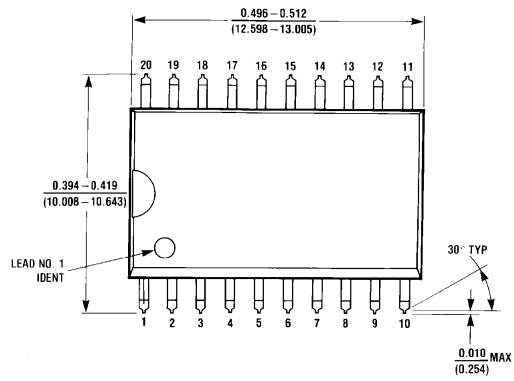

20-Lead (0.300" Wide) Molded Small Outline Package, JEDEC (S)
NS Package Number M20B

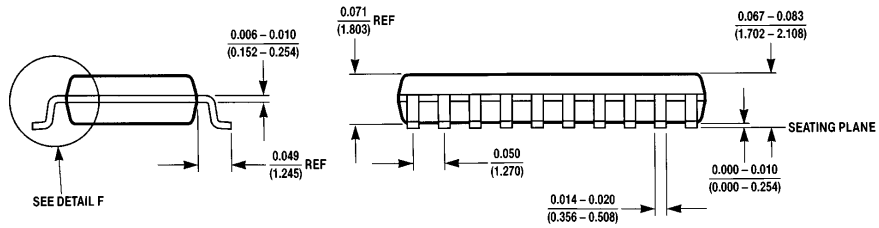
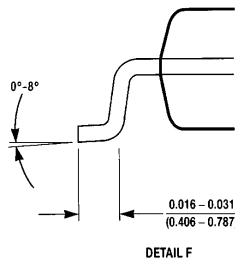
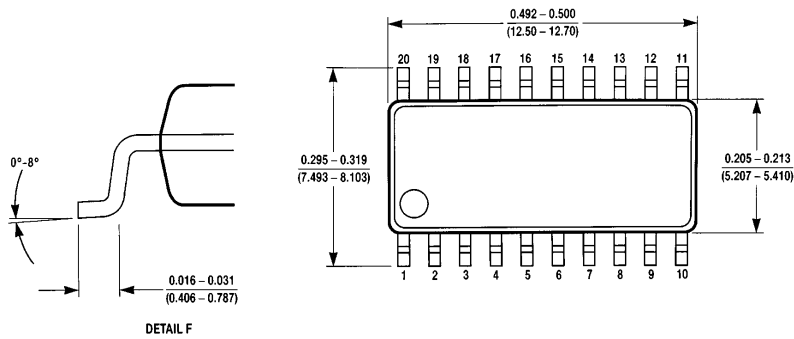

20-Lead (0.300" Wide) Molded Small Outline Package, EIAJ (SJ)
NS Package Number M20D

Physical Dimensions inches (millimeters) (Continued)

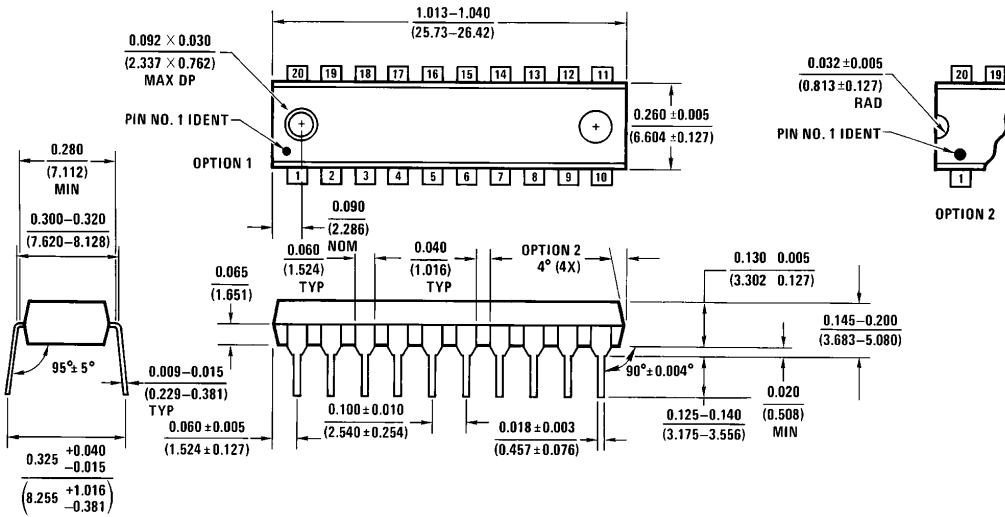

N20A (REV G)

**20-Lead (0.300" Wide) Molded Dual-In-Line Package (P)
NS Package Number N20A**

LIFE SUPPORT POLICY

NATIONAL'S PRODUCTS ARE NOT AUTHORIZED FOR USE AS CRITICAL COMPONENTS IN LIFE SUPPORT DEVICES OR SYSTEMS WITHOUT THE EXPRESS WRITTEN APPROVAL OF THE PRESIDENT OF NATIONAL SEMICONDUCTOR CORPORATION. As used herein:

1. Life support devices or systems are devices or systems which, (a) are intended for surgical implant into the body, or (b) support or sustain life, and whose failure to perform, when properly used in accordance with instructions for use provided in the labeling, can be reasonably expected to result in a significant injury to the user.
2. A critical component is any component of a life support device or system whose failure to perform can be reasonably expected to cause the failure of the life support device or system, or to affect its safety or effectiveness.



National Semiconductor Corporation
1111 West Bardin Road
Arlington, TX 76017
Tel: 1(800) 272-9959
Fax: 1(800) 737-7018

National Semiconductor Europe
Fax: (+49) 0-180-530 85 86
Email: cnjwge@tevm2.nsc.com
Deutsch Tel: (+49) 0-180-530 85 85
English Tel: (+49) 0-180-532 78 32
Français Tel: (+49) 0-180-532 93 58
Italiano Tel: (+49) 0-180-534 16 80

National Semiconductor Hong Kong Ltd.
19th Floor, Straight Block,
Ocean Centre, 5 Canton Rd.
Tsimshatsui, Kowloon
Hong Kong
Tel: (852) 2737-1600
Fax: (852) 2736-9960

National Semiconductor Japan Ltd.
Tel: 81-043-299-2309
Fax: 81-043-299-2408

National does not assume any responsibility for use of any circuitry described, no circuit patent licenses are implied and National reserves the right at any time without notice to change said circuitry and specifications.