



QUAD BUS TRANCEIVERS WITH 3-STATE OUTPUTS

The MC54/74F242 and MC54/74F243 are Quad Bus Transmitters/Receivers designed for 4-line asynchronous 2-way data communication between data buses.

- 2-Way Asynchronous Data Bus Communication
- Input Clamp Diodes Limit High-Speed Termination Effects
- ESD > 4000 Volts

MC54/74F242 (TOP VIEW)

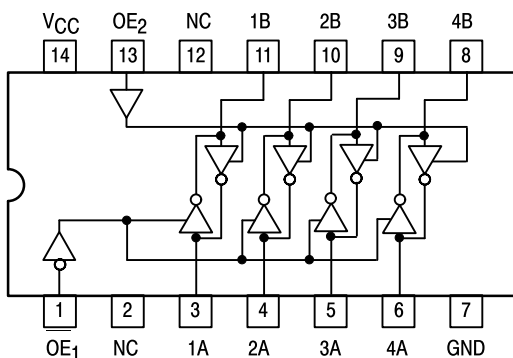

MC54/74F243 (TOP VIEW)

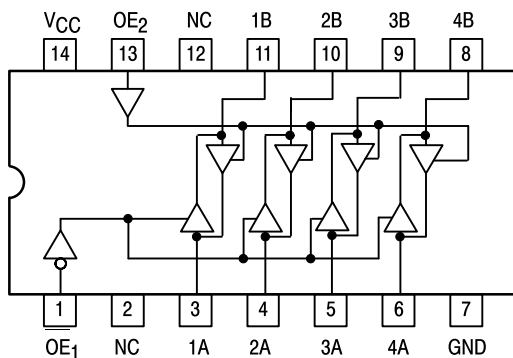

**MC54/74F242
MC54/74F243**

**QUAD BUS TRANSCIEVERS
WITH 3-STATE OUTPUTS**

FAST™ SCHOTTKY TTL

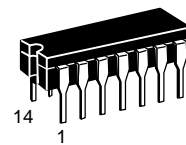

**J SUFFIX
CERAMIC
CASE 632-08**

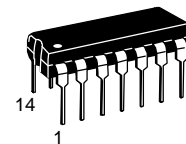

**N SUFFIX
PLASTIC
CASE 646-06**

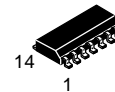

**D SUFFIX
SOIC
CASE 751A-02**

ORDERING INFORMATION

MC54FXXXJ Ceramic
MC74FXXXN Plastic
MC74FXXXD SOIC

GUARANTEED OPERATING RANGES

Symbol	Parameter		Min	Typ	Max	Unit
V _{CC}	Supply Voltage	54,74	4.5	5.0	5.5	V
T _A	Operating Ambient Temperature Range	54	-55	25	125	°C
		74	0	25	70	
I _{OH}	Output Current — High	54			-12	mA
		74			-15	
I _{OL}	Output Current — Low	54			48	mA
		74			64	

MC54/74F242 • MC54/74F243

FUNCTION TABLE – MC54/74F242

Inputs		Output	Inputs		Output
OE ₁	D		OE ₂	D	
L	L	H	L	X	Z
L	H	L	L	X	Z
H	X	Z	H	L	H
H	X	Z	H	H	L

FUNCTION TABLE – MC54/74F243

Inputs		Output	Inputs		Output
OE ₁	D		OE ₂	D	
L	L	L	L	X	Z
L	H	H	L	X	Z
H	X	Z	H	L	L
H	X	Z	H	H	H

H = HIGH Voltage Level; L = LOW Voltage Level; X = Don't Care; Z = HIGH Impedance

DC CHARACTERISTICS OVER OPERATING TEMPERATURE RANGE (unless otherwise specified)

Symbol	Parameter	Limits			Unit	Test Conditions	
		Min	Typ	Max			
V _{IH}	Input HIGH voltage	2.0			V	Guaranteed Input HIGH Voltage	
V _{IL}	Input LOW Voltage			0.8	V	Guaranteed Input LOW Voltage	
V _{IK}	Input Clamp Diode Voltage			-1.2	V	I _{IN} = -18 mA	V _{CC} = MIN
V _{OH}	Output HIGH Voltage	54	2.0		V	I _{OH} = -12 mA	V _{CC} = 4.50 V
		74	2.0		V	I _{OH} = -15 mA	V _{CC} = 4.50 V
		54, 74	2.4		V	I _{OH} = -3.0 mA	V _{CC} = 4.50 V
		74	2.7		V	I _{OH} = -3.0 mA	V _{CC} = 4.75 V
V _{OL}	Output LOW Voltage	54		0.55	V	I _{OL} = 48 mA	V _{CC} = MIN
		74		0.55	V	I _{OL} = 64 mA	
I _{OZH}	Output Off Current HIGH			70	μA	V _{OUT} = 2.7 V	V _{CC} = MAX
				1.0	mA	V _{OUT} = 5.5 V	
I _{OZL}	Output Off Current LOW			-1.6	mA	V _{OUT} = 0.5 V	V _{CC} = MAX
I _{IH}	Input HIGH Current	Enable		20	μA	V _{IN} = 2.7 V	V _{CC} = MAX
		Data		70	μA	V _{IN} = 2.7 V	
		Data		1.0	mA	V _{IN} = 5.5 V	
		Enable		0.1	mA	V _{IN} = 7.0 V	
I _{IL}	Input LOW Current	Enable		-1.0	mA	V _{IN} = 0.5 V	V _{CC} = MAX
		Data		-1.6	mA	V _{IN} = 0.5 V	
I _{OS}	Output Short Circuit Current (Note 2)	74	-100	-225	mA	V _{OUT} = 0 V	V _{CC} = MAX
		54	-100	-275	mA		
I _{CCH}	Power Supply Current HIGH	F242		60	mA	Outputs HIGH	V _{CC} = MAX
		F243		80	mA		
I _{CCL}	Power Supply Current LOW	F242		75	mA	Outputs LOW	V _{CC} = MAX
		F243		90	mA		
I _{CCZ}	Power Supply Current OFF	F242		75	mA	Outputs OFF	V _{CC} = MAX
		F243		90	mA		

NOTES:

1. For conditions shown as MIN or MAX, use the appropriate value specified under recommended operating conditions for the applicable device type.
2. Not more than one output should be shorted at a time, nor for more than 1 second.

MC54/74F242 • MC54/74F243

AC CHARACTERISTICS – MC54/74F242

Symbol	Parameter	54/74F		54F		74F		Unit
		$T_A = +25^\circ\text{C}$ $V_{CC} = +5.0\text{ V}$ $C_L = 50\text{ pF}$		$T_A = -55^\circ\text{C to } +125^\circ\text{C}$ $V_{CC} = 5.0\text{ V} \pm 10\%$ $C_L = 50\text{ pF}$		$T_A = 0^\circ\text{C to } 70^\circ\text{C}$ $V_{CC} = 5.0\text{ V} \pm 10\%$ $C_L = 50\text{ pF}$		
		Min	Max	Min	Max	Min	Max	
t _{PLH}	Propagation Delay,	2.5	7.0	2.5	9.0	2.5	8.0	ns
t _{PHL}	Data to Output	1.5	4.7	1.5	6.0	1.5	5.7	
t _{PZH}	Output Enable Time	2.0	4.7	2.0	6.5	2.0	5.7	ns
t _{PZL}		4.0	9.0	4.0	12	4.0	10	
t _{PHZ}	Output Disable Time	2.0	5.3	2.0	6.5	2.0	6.3	ns
t _{PLZ}		1.5	6.5	1.5	12.5	1.5	8.0	

AC CHARACTERISTICS – MC54/74F243

Symbol	Parameter	54/74F		54F		74F		Unit
		$T_A = +25^\circ\text{C}$ $V_{CC} = +5.0\text{ V}$ $C_L = 50\text{ pF}$		$T_A = -55^\circ\text{C to } +125^\circ\text{C}$ $V_{CC} = 5.0\text{ V} \pm 10\%$ $C_L = 50\text{ pF}$		$T_A = 0^\circ\text{C to } 70^\circ\text{C}$ $V_{CC} = 5.0\text{ V} \pm 10\%$ $C_L = 50\text{ pF}$		
		Min	Max	Min	Max	Min	Max	
t _{PLH}	Propagation Delay,	2.5	5.2	2.0	6.5	2.0	6.2	ns
t _{PHL}	Data to Output	2.5	5.2	2.0	8.5	2.0	6.5	
t _{PZH}	Output Enable Time	2.0	5.7	2.0	8.0	2.0	6.7	ns
t _{PZL}		2.0	7.5	2.0	10.5	2.0	8.5	
t _{PHZ}	Output Disable Time	2.0	6.0	1.5	7.5	1.5	7.0	ns
t _{PLZ}		1.5	6.5	2.0	12.5	1.5	7.5	

**Case 751A-02 D Suffix
14-Pin Plastic
SO-14**

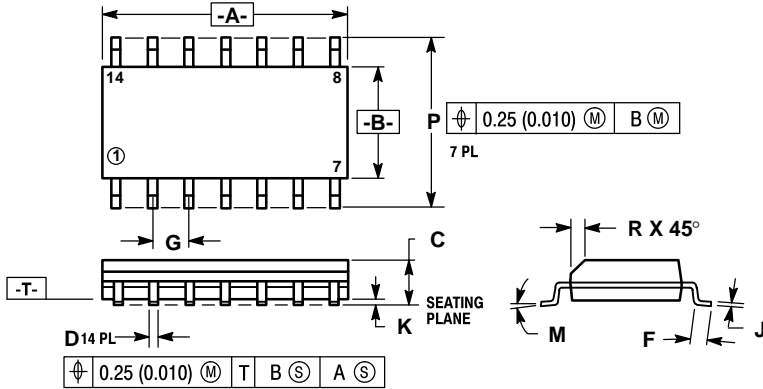

- NOTES:
1. DIMENSIONS "A" AND "B" ARE DATUMS AND "T" IS A DATUM SURFACE.
 2. DIMENSIONING AND TOLERANCING PER ANSI Y14.5M, 1982.
 3. CONTROLLING DIMENSION: MILLIMETER.
 4. DIMENSION A AND B DO NOT INCLUDE MOLD PROTRUSION.
 5. MAXIMUM MOLD PROTRUSION 0.15 (0.006) PER SIDE.
 6. 751A-01 IS OBSOLETE, NEW STANDARD 751A-02.

DIM	MILLIMETERS		INCHES	
	MIN	MAX	MIN	MAX
A	8.55	8.75	0.337	0.344
B	3.80	4.00	0.150	0.157
C	1.35	1.75	0.054	0.068
D	0.35	0.49	0.014	0.019
F	0.40	1.25	0.016	0.049
G	1.27 BSC		0.050 BSC	
J	0.19	0.25	0.008	0.009
K	0.10	0.25	0.004	0.009
M	0°	7°	0°	7°
P	5.80	6.20	0.229	0.244
R	0.25	0.50	0.010	0.019

**Case 632-08 J Suffix
14-Pin Ceramic Dual In-Line**

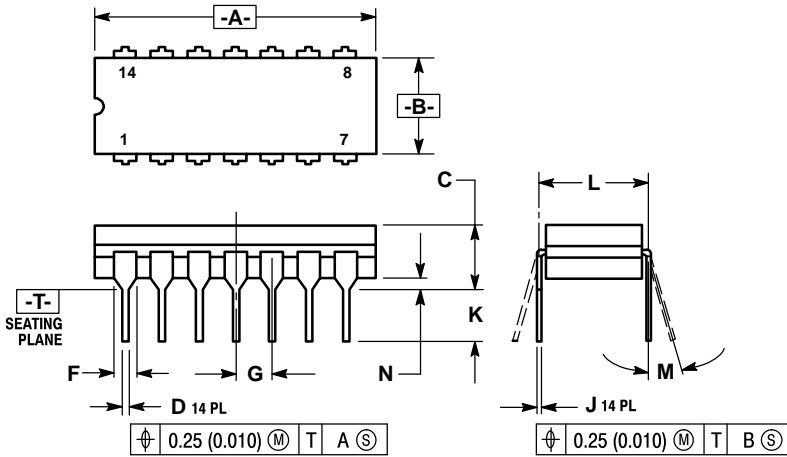

- NOTES:
1. DIMENSIONING AND TOLERANCING PER ANSI Y14.5M, 1982.
 2. CONTROLLING DIMENSION: INCH.
 3. DIMENSION L TO CENTER OF LEAD WHEN FORMED PARALLEL.
 4. DIM F MAY NARROW TO 0.76 (0.030) WHERE THE LEAD ENTERS THE CERAMIC BODY.
 5. 632-01 THRU -07 OBSOLETE, NEW STANDARD 632-08.

DIM	MILLIMETERS		INCHES	
	MIN	MAX	MIN	MAX
A	19.05	19.94	0.750	0.785
B	6.23	7.11	0.245	0.280
C	3.94	5.08	0.155	0.200
D	0.39	0.50	0.015	0.020
F	1.40	1.65	0.055	0.065
G	2.54 BSC		0.100 BSC	
J	0.21	0.38	0.008	0.015
K	3.18	4.31	0.125	0.170
L	7.62 BSC		0.300 BSC	
M	0°	15°	0°	15°
N	0.51	1.01	0.020	0.040

**Case 646-06 N Suffix
14-Pin Plastic**

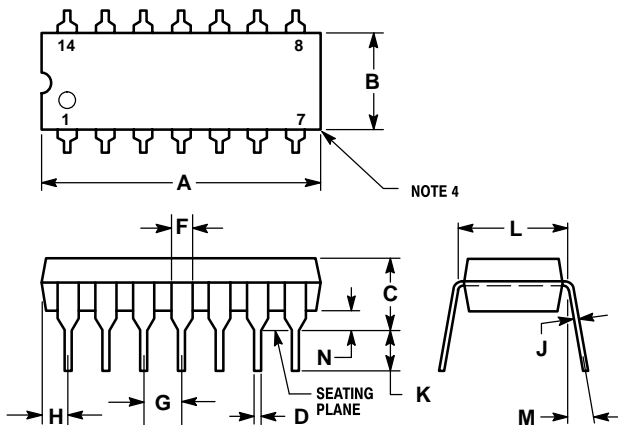

- NOTES:
1. LEADS WITHIN 0.13 mm (0.005) RADIUS OF TRUE POSITION AT SEATING PLANE AT MAXIMUM MATERIAL CONDITION.
 2. DIMENSION "L" TO CENTER OF LEADS WHEN FORMED PARALLEL.
 3. DIMENSION "B" DOES NOT INCLUDE MOLD FLASH.
 4. ROUNDED CORNERS OPTIONAL.
 5. 646-05 OBSOLETE, NEW STANDARD 646-06.

DIM	MILLIMETERS		INCHES	
	MIN	MAX	MIN	MAX
A	18.16	19.56	0.715	0.770
B	6.10	6.60	0.240	0.260
C	3.69	4.69	0.145	0.185
D	0.38	0.53	0.015	0.021
F	1.02	1.78	0.040	0.070
G	2.54 BSC		0.100 BSC	
H	1.32	2.41	0.052	0.095
J	0.20	0.38	0.008	0.015
K	2.92	3.43	0.115	0.135
L	7.62 BSC		0.300 BSC	
M	0°	10°	0°	10°
N	0.39	1.01	0.015	0.039

Motorola reserves the right to make changes without further notice to any products herein. Motorola makes no warranty, representation or guarantee regarding the suitability of its products for any particular purpose, nor does Motorola assume any liability arising out of the application or use of any product or circuit, and specifically disclaims any and all liability, including without limitation consequential or incidental damages. "Typical" parameters can and do vary in different applications. All operating parameters, including "Typicals" must be validated for each customer application by customer's technical experts. Motorola does not convey any license under its patent rights nor the rights of others. Motorola products are not designed, intended, or authorized for use as components in systems intended for surgical implant into the body, or other applications intended to support or sustain life, or for any other application in which the failure of the Motorola product could create a situation where personal injury or death may occur. Should Buyer purchase or use Motorola products for any such unintended or unauthorized application, Buyer shall indemnify and hold Motorola and its officers, employees, subsidiaries, affiliates, and distributors harmless against all claims, costs, damages, and expenses, and reasonable attorney fees arising out of, directly or indirectly, any claim of personal injury or death associated with such unintended or unauthorized use, even if such claim alleges that Motorola was negligent regarding the design or manufacture of the part. Motorola and TM are registered trademarks of Motorola, Inc. Motorola, Inc. is an Equal Opportunity/Affirmative Action Employer.

Literature Distribution Centers:

USA: Motorola Literature Distribution; P.O. Box 20912; Phoenix, Arizona 85036.

EUROPE: Motorola Ltd.; European Literature Centre; 88 Tanners Drive, Blakelands, Milton Keynes, MK14 5BP, England.

JAPAN: Nippon Motorola Ltd.; 4-32-1, Nishi-Gotanda, Shinagawa-ku, Tokyo 141, Japan.

ASIA PACIFIC: Motorola Semiconductors H.K. Ltd.; Silicon Harbour Center, No. 2 Dai King Street, Tai Po Industrial Estate, Tai Po, N.T., Hong Kong.

