

- Package Options Include Plastic and Ceramic DIPs and Ceramic Flat Packages
- Dependable Texas Instruments Quality and Reliability

SN54111 . . . J PACKAGE
 SN74111 . . . N PACKAGE
 (TOP VIEW)

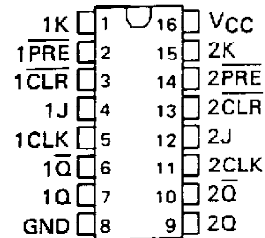

description

The SN54111 and SN74111 are d-c coupled, variable-skew, J-K flip-flops which utilize TTL circuitry to obtain 25-MHz performance typically. They are termed "variable-skew" because they allow the maximum clock skew in a system to be a direct function of the clock pulse width. The J and K inputs are enabled to accept data only during a short period (30 nanoseconds maximum hold time) starting with, and immediately following the rising edge of the clock pulse. After this, inputs may be changed while the clock is at the high level without affecting the state of the master. At the threshold level of the falling edge of the clock pulse, the data stored in the master will be transferred to the output. The effective allowable clock skew then is minimum propagation delay time minus hold time, plus clock pulse width. This means that the system designer can set the maximum allowable clock skew needed by varying the clock pulse width. Thus system design is made easier and the requirements for sophisticated clock distribution systems are minimized or, in some cases, entirely eliminated. These flip-flops have an additional feature—the synchronous input has reduced sensitivity to data change while the clock is high because the data need be present for only a short period of time and the system's susceptibility to noise is thereby effectively reduced.

The SN54111 is characterized for operation over the full military temperature range of -55°C to 125°C ; the SN74111 is characterized for operation from 0°C to 70°C .

FUNCTION TABLE

INPUTS					OUTPUTS	
PRE	CLR	CLK	J	K	Q	Q-bar
L	H	X	X	X	H	L
H	L	X	X	X	L	H
L	L	X	X	X	H [‡]	H [‡]
H	H		L	L	Q ₀	Q ₀ -bar
H	H		H	L	H	L
H	H		L	H	L	H
H	H		H	H	TOGGLE	

[‡]This configuration is non-stable; that is, it will not persist when preset or clear return to their inactive (high) level.

logic symbol†

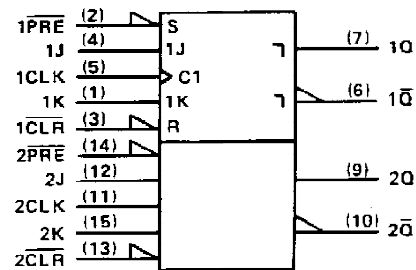

[†]This symbol is in accordance with ANSI/IEEE Std 91-1984 and IEC Publication 617-12.

PRODUCTION DATA documents contain information current as of publication date. Products conform to specifications per the terms of Texas Instruments standard warranty. Production processing does not necessarily include testing of all parameters.

TEXAS
 INSTRUMENTS

POST OFFICE BOX 655012 • DALLAS, TEXAS 75265

SN54111, SN74111 DUAL J-K MASTER-SLAVE FLIP-FLOPS WITH DATA LOCKOUT

logic diagram (positive logic)

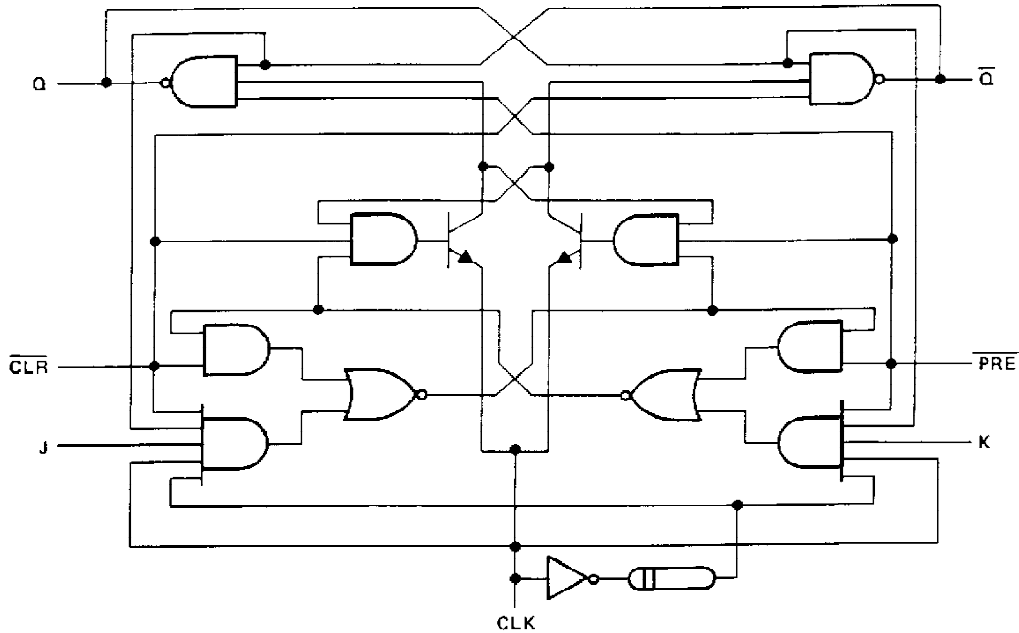

schematics of inputs and outputs

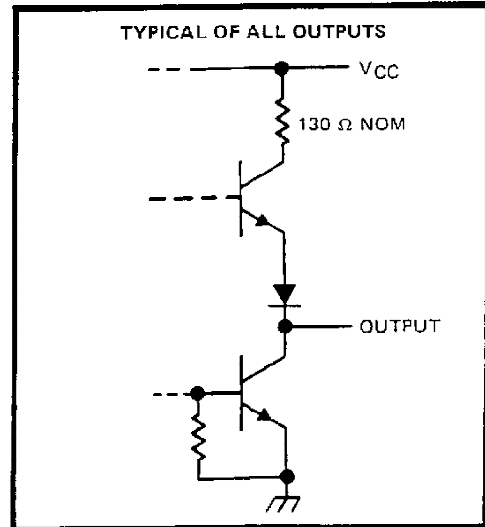
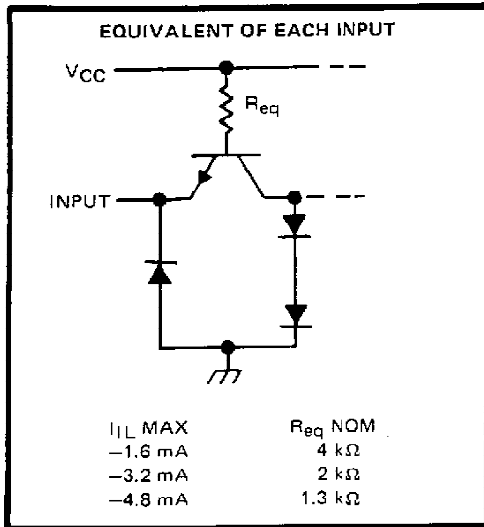

absolute maximum ratings over operating free-air temperature range (unless otherwise noted)

Supply voltage, V_{CC} (see Note 1)	7 V
Input voltage	5.5 V
Operating free-air temperature range: SN54111	-55°C to 125°C
SN74111	0°C to 70°C
Storage temperature range	-65°C to 150°C

NOTE 1: Voltage values are with respect to network ground terminal.

TEXAS
INSTRUMENTS

POST OFFICE BOX 655012 • DALLAS, TEXAS 75265

SN54111, SN74111

DUAL J-K MASTER-SLAVE FLIP-FLOPS WITH DATA LOCKOUT

recommended operating conditions

		SN54111			SN74111			UNIT	
		MIN	NOM	MAX	MIN	NOM	MAX		
V _{CC}	Supply voltage	4.5	5	5.5	4.75	5	5.25	V	
V _{IH}	High-level input voltage	2			2			V	
V _{IL}	Low-level input voltage	0.8			0.8			V	
I _{OH}	High-level output current	-0.8			-0.8			mA	
I _{OL}	Low-level output current	16			16			mA	
t _w	Pulse duration	CLK high or low	25		25		ns		
		PRE or CLR low	25		25				
t _{su}	Input setup time before CLK †	0			0			ns	
t _h	Input hold time data after CLK †	30			30			ns	
T _A	Operating free-air temperature	-55		125		0		70	°C

electrical characteristics over recommended operating free-air temperature range (unless otherwise noted)

PARAMETER	TEST CONDITIONS †	SN54111			SN74111			UNIT		
		MIN	TYP ‡	MAX	MIN	TYP ‡	MAX			
V _{IK}	V _{CC} = MIN, I _I = -12 mA	-1.5			-1.5			V		
V _{OH}	V _{CC} = MIN, V _{IH} = 2 V, V _{IL} = 0.8 V, I _{OH} = -0.8 mA	2.4	3.4		2.4	3.4		V		
V _{OL}	V _{CC} = MIN, V _{IH} = 2 V, V _{IL} = 0.8 V, I _{OL} = 16 mA	0.2			0.2			V		
I _I	V _{CC} = MAX, V _I = 5.5 V	1			1			mA		
I _{IH}	J or K	40			40			μA		
	CLR or PRE	80			80					
	CLK	120			120					
I _{IL}	J or K	-1.6			-1.6			mA		
	CLR †	-3.2			-3.2					
	PRE †	-3.2			-3.2					
	CLK	-4.8			-4.8					
I _{OS} §	V _{CC} = MAX	-20		-57	-18		-57	mA		
I _{CC} #	V _{CC} = MAX, See Note 2	14		20.5		14		20.5		mA

† For conditions shown as MIN or MAX, use the appropriate value specified under recommended operating conditions.

‡ All typical values are at V_{CC} = 5 V, T_A = 25°C.

§ Not more than one output should be shorted at a time.

† Clear is tested with preset high and preset is tested with clear high.

Average per flip-flop.

NOTE 2: With all outputs open, I_{CC} is measured with the Q and \bar{Q} outputs high in turn. At the time of measurement, the clock input is at 4.5 V.

switching characteristics, V_{CC} = 5 V, T_A = 25°C (see note 3)

PARAMETER	FROM (INPUT)	TO (OUTPUT)	TEST CONDITIONS	MIN	TYP	MAX	UNIT
f _{max}				20	25		MHz
t _{PLH}	PRE or CLR	Q or \bar{Q}	R _L = 400 Ω, C _L = 15 pF	12	18		ns
t _{PHL}				21	30		ns
t _{PLH}	CLK	Q or \bar{Q}		12	17		ns
t _{PHL}				20	30		ns

NOTE 3: Load circuits and voltage waveforms are shown in Section 1.

TEXAS
INSTRUMENTS

POST OFFICE BOX 655012 • DALLAS, TEXAS 75265

IMPORTANT NOTICE

Texas Instruments (TI) reserves the right to make changes to its products or to discontinue any semiconductor product or service without notice, and advises its customers to obtain the latest version of relevant information to verify, before placing orders, that the information being relied on is current.

TI warrants performance of its semiconductor products and related software to the specifications applicable at the time of sale in accordance with TI's standard warranty. Testing and other quality control techniques are utilized to the extent TI deems necessary to support this warranty. Specific testing of all parameters of each device is not necessarily performed, except those mandated by government requirements.

Certain applications using semiconductor products may involve potential risks of death, personal injury, or severe property or environmental damage ("Critical Applications").

TI SEMICONDUCTOR PRODUCTS ARE NOT DESIGNED, INTENDED, AUTHORIZED, OR WARRANTED TO BE SUITABLE FOR USE IN LIFE-SUPPORT APPLICATIONS, DEVICES OR SYSTEMS OR OTHER CRITICAL APPLICATIONS.

Inclusion of TI products in such applications is understood to be fully at the risk of the customer. Use of TI products in such applications requires the written approval of an appropriate TI officer. Questions concerning potential risk applications should be directed to TI through a local SC sales office.

In order to minimize risks associated with the customer's applications, adequate design and operating safeguards should be provided by the customer to minimize inherent or procedural hazards.

TI assumes no liability for applications assistance, customer product design, software performance, or infringement of patents or services described herein. Nor does TI warrant or represent that any license, either express or implied, is granted under any patent right, copyright, mask work right, or other intellectual property right of TI covering or relating to any combination, machine, or process in which such semiconductor products or services might be or are used.

IMPORTANT NOTICE

Texas Instruments and its subsidiaries (TI) reserve the right to make changes to their products or to discontinue any product or service without notice, and advise customers to obtain the latest version of relevant information to verify, before placing orders, that information being relied on is current and complete. All products are sold subject to the terms and conditions of sale supplied at the time of order acknowledgement, including those pertaining to warranty, patent infringement, and limitation of liability.

TI warrants performance of its semiconductor products to the specifications applicable at the time of sale in accordance with TI's standard warranty. Testing and other quality control techniques are utilized to the extent TI deems necessary to support this warranty. Specific testing of all parameters of each device is not necessarily performed, except those mandated by government requirements.

CERTAIN APPLICATIONS USING SEMICONDUCTOR PRODUCTS MAY INVOLVE POTENTIAL RISKS OF DEATH, PERSONAL INJURY, OR SEVERE PROPERTY OR ENVIRONMENTAL DAMAGE ("CRITICAL APPLICATIONS"). TI SEMICONDUCTOR PRODUCTS ARE NOT DESIGNED, AUTHORIZED, OR WARRANTED TO BE SUITABLE FOR USE IN LIFE-SUPPORT DEVICES OR SYSTEMS OR OTHER CRITICAL APPLICATIONS. INCLUSION OF TI PRODUCTS IN SUCH APPLICATIONS IS UNDERSTOOD TO BE FULLY AT THE CUSTOMER'S RISK.

In order to minimize risks associated with the customer's applications, adequate design and operating safeguards must be provided by the customer to minimize inherent or procedural hazards.

TI assumes no liability for applications assistance or customer product design. TI does not warrant or represent that any license, either express or implied, is granted under any patent right, copyright, mask work right, or other intellectual property right of TI covering or relating to any combination, machine, or process in which such semiconductor products or services might be or are used. TI's publication of information regarding any third party's products or services does not constitute TI's approval, warranty or endorsement thereof.