

μA709 High Performance Operational Amplifier

Linear Division Operational Amplifiers

Description

The μA709 is a monolithic high gain operational amplifier constructed using the Fairchild Planar Epitaxial process. It features low offset, high input impedance, large input common mode range, high output swing under load, and low power consumption. The device displays exceptional temperature stability and will operate over a wide range of supply voltages with little performance degradation. The amplifier is intended for use in DC servo systems, high impedance analog computers, low level instrumentation applications, and for the generation of special linear and nonlinear transfer functions.

Connection Diagram 8-Lead DIP and SO-8 Package (Top View)

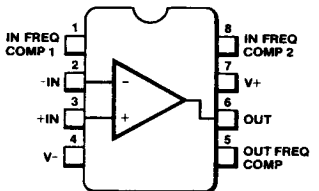

CD00721F

Order Information

Device Code	Package Code	Package Description
μA709TC	9T	Molded DIP
μA709SC	KC	Molded Surface Mount

Connection Diagram 8-Lead Metal Package (Top View)

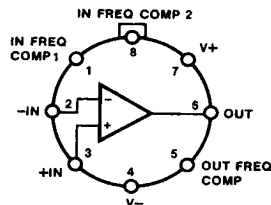

CD00721F

Lead 4 connected to case

Order Information

Device Code	Package Code	Package Description
μA709AHM	5W	Metal
μA709HM	5W	Metal
μA709HC	5W	Metal

Connection Diagram 14-Lead DIP (Top View)

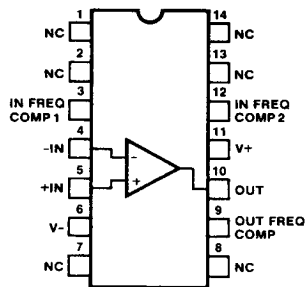

CD00741F

Order Information

Device Code	Package Code	Package Description
μA709PC	9A	Molded DIP

Absolute Maximum Ratings

Storage Temperature Range	
Metal Can	-65°C to +175°C
Molded DIP and SO-8	-65°C to +150°C
Operating Temperature Range	
Extended (μA709AM, μA709M)	-55°C to +125°C
Commercial (μA709C)	0°C to +70°C
Lead Temperature	
Metal Can (soldering, 60 s)	300°C
Molded DIP and SO-8 (soldering, 10s)	265°C

Internal Power Dissipation^{1, 2}

8L-Metal Can	1.00 W
8L-Molded DIP	0.93 W
SO-8	0.81 W
14L-Molded DIP	1.04 W
Supply Voltage	± 18 V
Differential Input Voltage	± 5.0 V
Input Voltage	± 10 V
Output Short Circuit Duration	5.0 s

Notes

1. $T_{J \text{ Max}} = 150^\circ\text{C}$ for the Molded DIP and SO-8, and 175°C for the Metal Can.
2. Ratings apply to ambient temperature at 25°C . Above this temperature, derate the 8L-Metal Can at $6.7 \text{ mW}/^\circ\text{C}$, the 8L-Molded DIP at $7.5 \text{ mW}/^\circ\text{C}$, the SO-8 at $6.5 \text{ mW}/^\circ\text{C}$, and the 14L-Molded DIP at $8.3 \text{ mW}/^\circ\text{C}$.

Equivalent Circuit

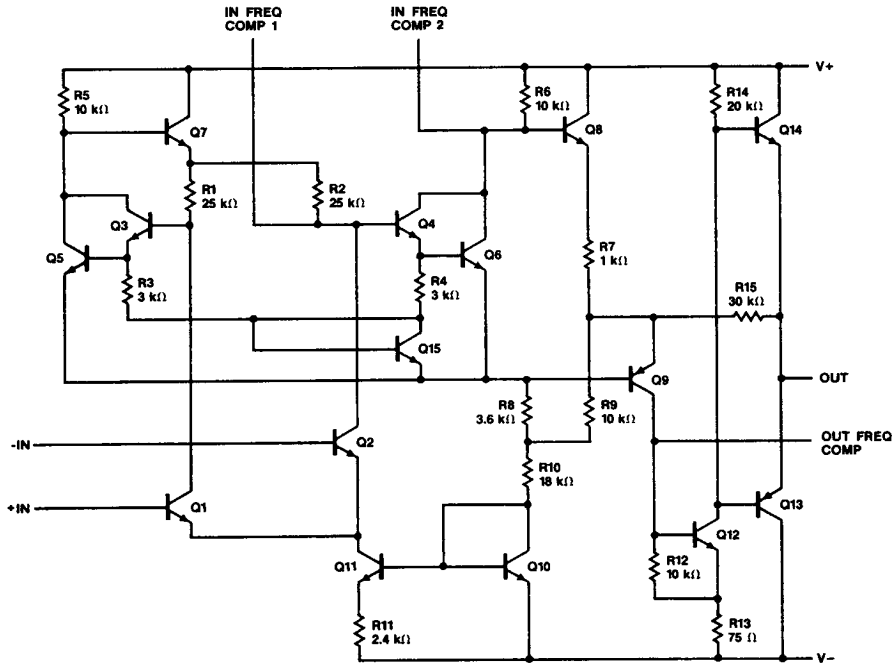

EO00151F

μA709

μA709A and μA709

Electrical Characteristics $T_A = 25^\circ\text{C}$, $\pm 9.0\text{ V} \leq V_{CC} \leq \pm 15\text{ V}$, unless otherwise specified.

Symbol	Characteristic		Condition	μA709A			μA709			Unit
				Min	Typ	Max	Min	Typ	Max	
V_{IO}	Input Offset Voltage		$R_S \leq 10\text{ k}\Omega$		0.6	2.0		1.0	5.0	mV
I_{IO}	Input Offset Current				10	50		50	200	nA
I_{IB}	Input Bias Current				100	200		200	500	nA
Z_I	Input Impedance			350	700		150	400		kΩ
I_{CC}	Supply Current		$V_{CC} = \pm 15\text{ V}$		2.5	3.6		2.7	5.5	mA
P_c	Power Consumption		$V_{CC} = \pm 15\text{ V}$		75	108		80	165	mW
TR	Transient Response	Rise time	$V_{CC} = \pm 15\text{ V}$ $V_I = 20\text{ mV}$ $R_L = 2.0\text{ k}\Omega$ $C_1 = 5.0\text{ nF}$ $A_V = 1.0$		0.3	1.5		0.3	1.0	μs
		Overshoot	$R_2 = 50\ \Omega$ $C_L \leq 100\text{ pF}$ $R_1 = 1.5\text{ k}\Omega$ $C_2 = 200\text{ pF}$ $A_V = 1.0$		10	30		10	30	%

The following specifications apply over the range of -55°C to $+125^\circ\text{C}$ for the μA709A and μA709.

V_{IO}	Input Offset Voltage	$R_S \leq 10\text{ k}\Omega$			3.0			6.0		mV
$\Delta V_{IO}/\Delta T$	Input Offset Voltage Temperature Sensitivity	$R_S = 50\ \Omega$		1.8	10		3.0			μV/°C
		$R_S \leq 10\text{ k}\Omega$		4.8	25		6.0			
I_{IO}	Input Offset Current	$T_A = +125^\circ\text{C}$		3.5	50		20	200		nA
		$T_A = -55^\circ\text{C}$		40	250		100	500		
$\Delta I_{IO}/\Delta T$	Input Offset Current Temperature Sensitivity	$T_A = +25^\circ\text{C}$ to $+125^\circ\text{C}$		0.08	0.5					nA/°C
		$T_A = +25^\circ\text{C}$ to -55°C		0.45	2.8					
I_{IB}	Input Bias Current	$T_A = -55^\circ\text{C}$		300	600		500	1500		nA
$\Delta I_{IB}/\Delta T$	Input Bias Current Temperature Sensitivity	$T_A = +125^\circ\text{C}$		2.1	3.0					nA/°C
		$T_A = -55^\circ\text{C}$		2.7	4.5					
Z_I	Input Impedance	$T_A = -55^\circ\text{C}$	85	170		40	100			kΩ
CMR	Common Mode Rejection	$R_S \leq 10\text{ k}\Omega$	80	110		70	90			db
V_{IR}	Input Voltage Range	$V_{CC} = \pm 15\text{ V}$	± 8.0	± 10		± 8.0	± 10			V
PSRR	Power Supply Rejection Ratio	$R_S \leq 10\text{ k}\Omega$		40	100		50	150		μV/V
A_{Vs}	Large Signal Voltage Gain	$V_{CC} = \pm 15\text{ V}$ $R_L \geq 2.0\text{ k}\Omega$ $V_O = \pm 10\text{ V}$	25		70	25	45	70		V/mV
V_{OP}	Output Voltage Swing	$V_{CC} = \pm 15\text{ V}$ $R_L = 10\text{ k}\Omega$	± 12	± 14		± 12	± 14			V
		$V_{CC} = \pm 15\text{ V}$ $R_L = 2.0\text{ k}\Omega$	± 10	± 13		± 10	± 13			

μA709

μA709A and μA709 (Cont.)

Electrical Characteristics $T_A = 25^\circ\text{C}$, $\pm 9.0\text{ V} \leq V_{CC} \leq \pm 15\text{ V}$, unless otherwise specified.

Symbol	Characteristic	Condition	μA709A			μA709			Unit
			Min	Typ	Max	Min	Typ	Max	
I_{CC}	Supply Current	$T_A = \pm 125^\circ\text{C}$		2.1	3.0				mA
		$T_A = -55^\circ\text{C}$		2.7	4.5				

μA709C

Electrical Characteristics $T_A = 25^\circ\text{C}$, $V_{CC} = \pm 15\text{ V}$, unless otherwise specified.

Symbol	Characteristic		Condition	μA709C			Unit
				Min	Typ	Max	
V_{IO}	Input Offset Voltage		$R_S \leq 10\text{ k}\Omega$		2.0	7.5	mV
I_{IO}	Input Offset Current				100	500	nA
I_{IB}	Input Bias Current				300	1500	nA
Z_i	Input Impedance			50	250		kΩ
I_{CC}	Supply Current		$V_{CC} = \pm 15\text{ V}$		2.7	6.66	mA
P_c	Power Consumption		$V_{CC} = \pm 15\text{ V}$		80	200	mW
CMR	Common Mode Rejection		$R_S \leq 10\text{ k}\Omega$	65	90		dB
V_{IR}	Input Voltage Range		$V_{CC} = \pm 15\text{ V}$	± 8.0	± 10		V
PSRR	Power Supply Rejection Ratio		$R_S \leq 10\text{ k}\Omega$		50	200	μV/V
TR	Transient Response	Rise time	$V_{CC} = \pm 15\text{ V}$ $V_i = 20\text{ mV}$ $R_L = 2.0\text{ k}\Omega$ $C_1 = 5.0\text{ nF}$ $A_V = 1.0$		0.3		μs
		Overshoot	$R_2 = 50\ \Omega$ $C_L = 100\text{ pF}$ $R_1 = 1.5\text{ k}\Omega$ $C_2 = 200\text{ pF}$ $A_V = 1.0$		10		%

The following specifications apply over the range of 0°C to $+70^\circ\text{C}$.

V_{IO}	Input Offset Voltage	$R_S \leq 10\text{ k}\Omega$			10.0	mV
I_{IO}	Input Offset Current	$T_A = 0^\circ\text{C}$			750	nA
I_{IB}	Input Bias Current	$T_A = 0^\circ\text{C}$			2000	nA
Z_i	Input Impedance	$T_A = 0^\circ\text{C}$	35	80		kΩ
A_{VS}	Large Signal Voltage Gain	$V_{CC} = \pm 15\text{ V}$ $R_L \geq 2.0\text{ k}\Omega$ $V_O = \pm 10\text{ V}$	15	45		V/mV
V_{OP}	Output Voltage Swing	$V_{CC} = \pm 15\text{ V}$ $R_L = 10\text{ k}\Omega$	± 12	± 14		V
		$V_{CC} = \pm 15\text{ V}$ $R_L = 2.0\text{ k}\Omega$	± 10	± 13		V

Typical Performance Curves for μ A709A

Voltage Gain vs Supply Voltage

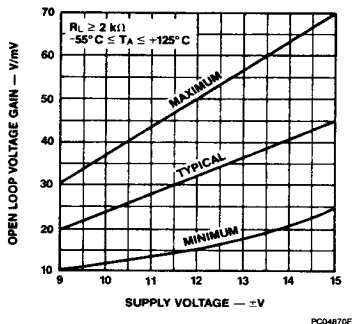

Output Voltage Swing vs Supply Voltage

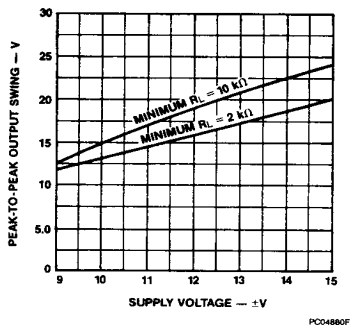

Input Common Mode Voltage Range vs Supply Voltage

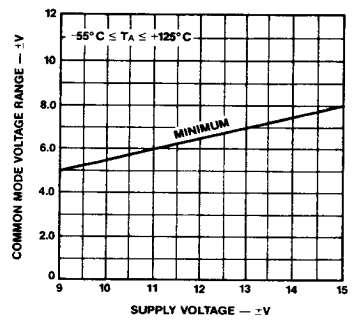

Voltage Transfer Characteristics

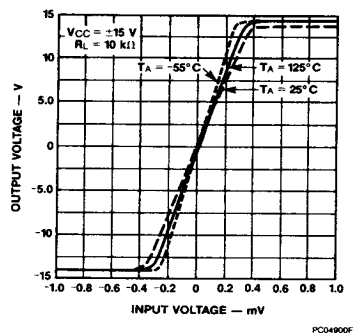

Voltage Gain vs Temperature

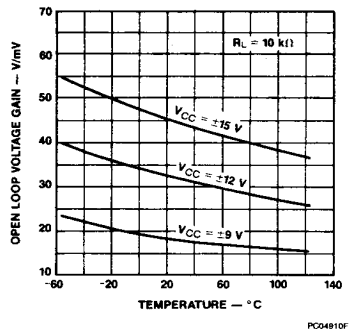

Output Voltage Swing vs Load Resistance

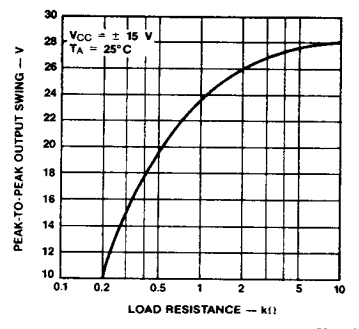

Input Bias Current vs Temperature

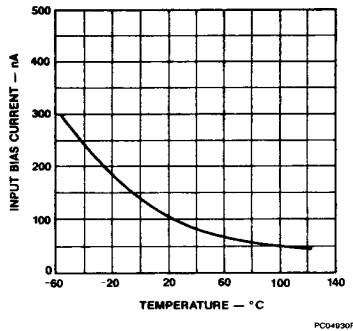

Input Bias Current vs Supply Voltage

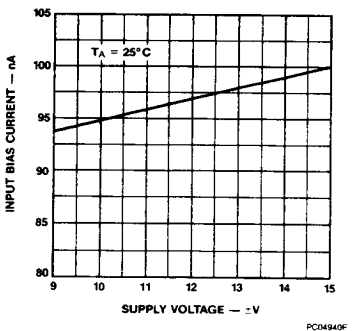

Input Offset Current vs Temperature

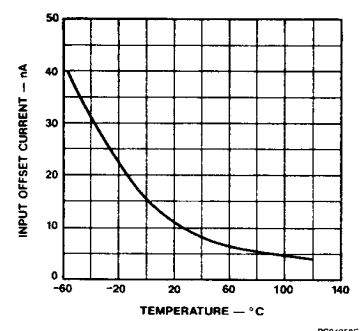

Typical Performance Curves for μA709A (Cont.)

Common Mode Rejection Ratio vs Temperature

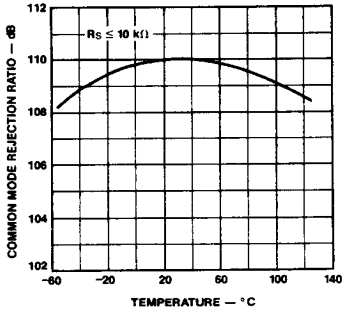

Input Resistance vs Temperature

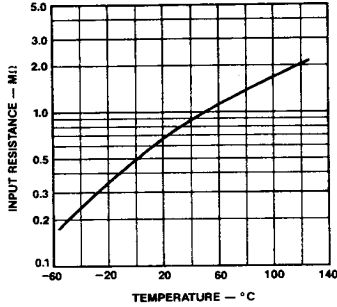

Power Consumption vs Temperature

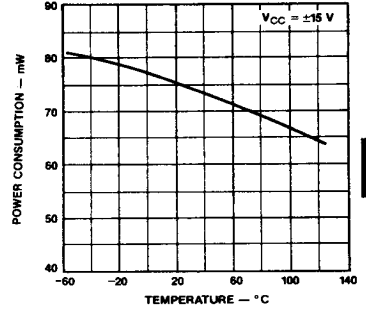

Transient Response

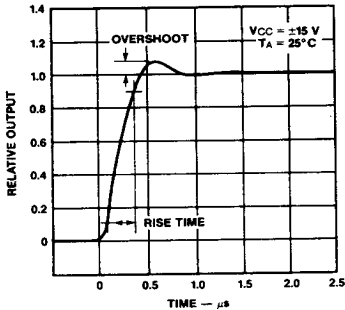

Power Consumption vs Supply Voltage

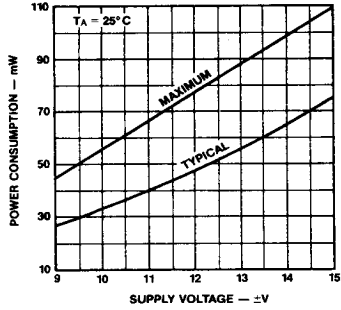

Slew Rate vs Closed Loop Gain Using Recommended Compensation Networks

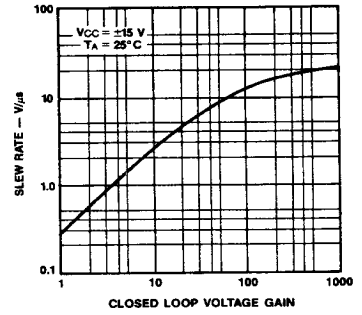

Power Consumption vs Supply Voltage (μA709 and μA709C)

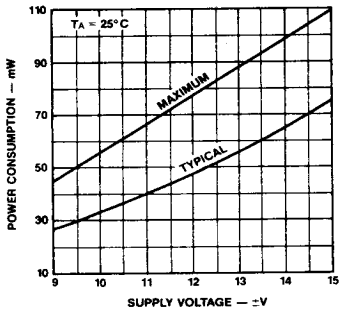

Voltage Transfer Characteristics (μA709 and μA709C)

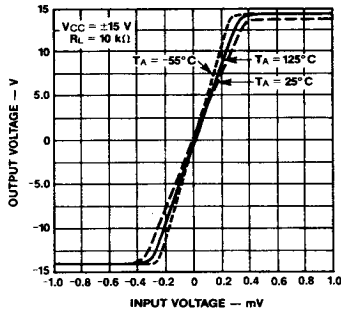

Input Bias Current vs Temperature (μA709 and μA709C)

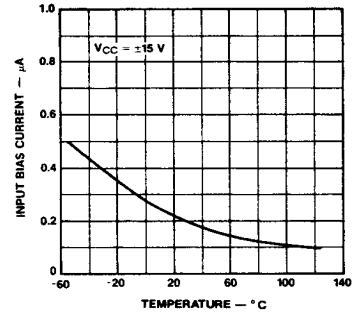

Typical Performance Curves for $\mu A709$ and $\mu A709C$ (Cont.)

Input Offset Current vs Temperature

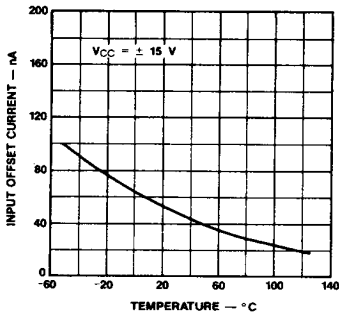

PC05030F

Input Resistance vs Temperature

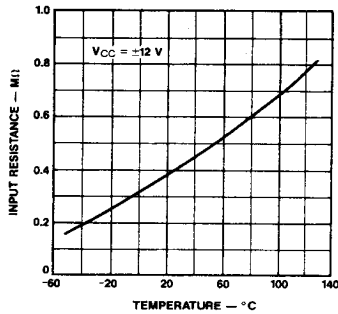

PC05040F

Power Consumption vs Temperature

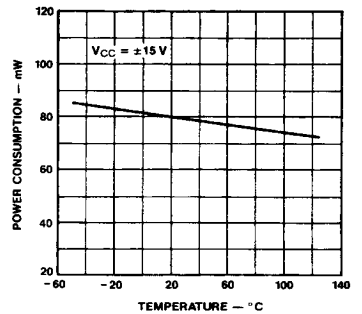

PC05051F

Output Voltage Swing vs Load Resistance

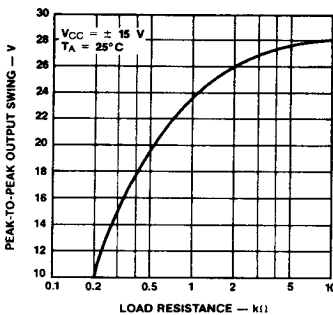

PC04920F

Output Voltage Swing vs Supply Voltage

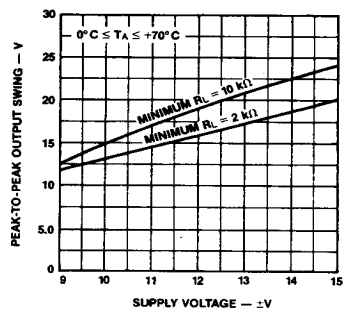

PC05060F

Transient Response

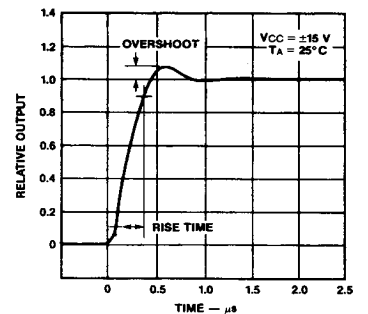

PC04901F

Input Bias Current vs Supply Voltage

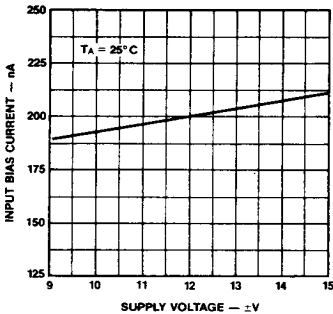

PC05080F

Frequency Characteristics vs Supply Voltage

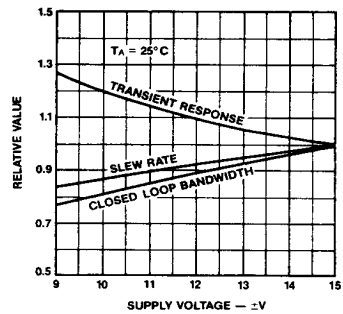

PC05070F

Frequency Characteristics vs Temperature

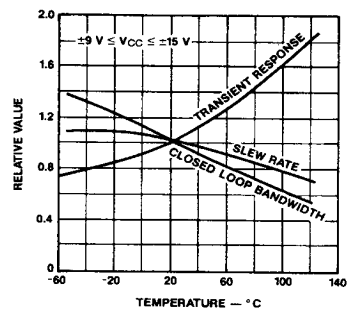

PC05081F

Typical Performance Curves for μA709 and μA709C (Cont.)

Voltage Gain vs Supply Voltage (μA709C)

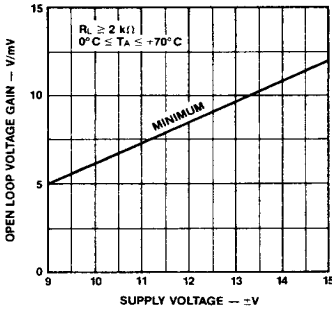

PC05100F

Voltage Gain vs Supply Voltage (μA709)

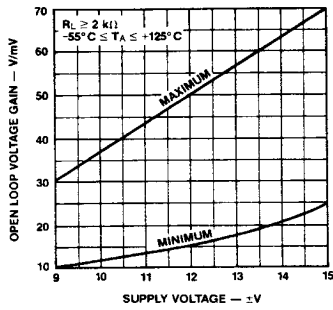

PC05110F

Input Common Mode Voltage Range vs Supply Voltage

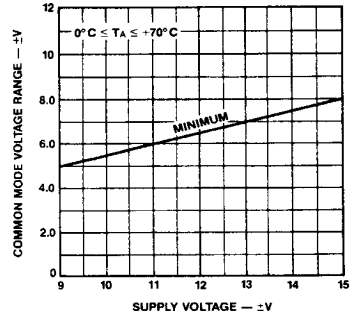

PC05121F

7

Frequency Compensation Curves For All Types

Open Loop Frequency Response For Various Values Of Compensation

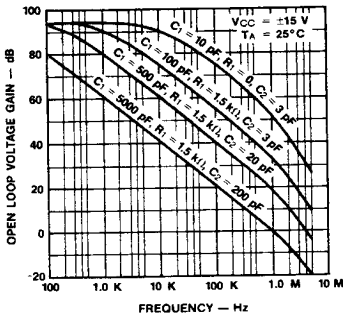

PC05131F

Frequency Response For Various Closed Loop Gains

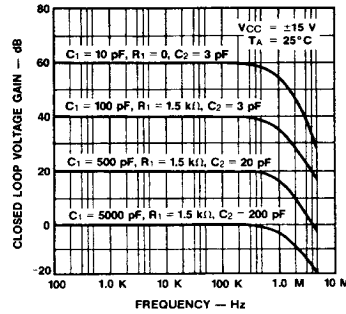

PC05141F

Output Voltage Swing vs Frequency For Various Values Of Compensation

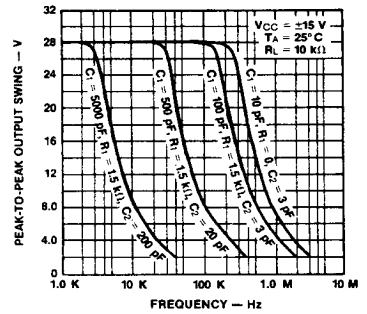

PC05151F

Test Circuits

Transient Response Circuit

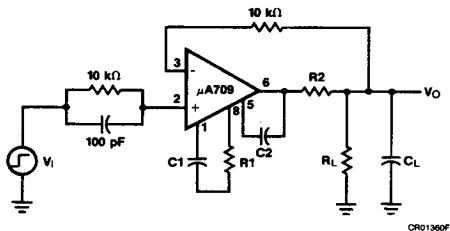

CR01360F

Frequency Compensation Circuit

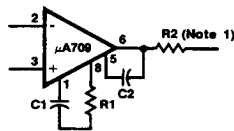

CR01371F

Protection Circuits

Output Short Circuit Protection

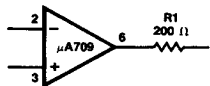

CR01380F

Input Breakdown Protection

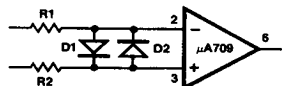

CR01390F

Latch Up Protection

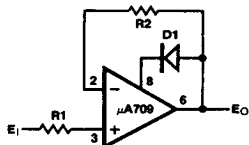

CR01400F

Supply Over Voltage Protection

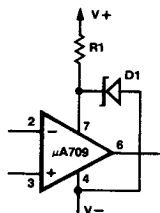

CR01410F

Note

1. Use $R_2 = 50 \Omega$ when the amplifier is operated with capacitive loading.