

Display Drivers

T-52-13-07

U 123 P • Photo pulse amplifier

Features:

- Integrated operational amplifier and photo detector on one chip
- External controlled photo sensitivity through R_{2-3}
- Quiescent current $I_{SB} = 11 \text{ mA}$
- For $R_{2-3} \geq 50 \text{ k}\Omega$ internal frequency compensations
- No influence of primary illumination up to $E \leq 15 \text{ klx}$, $f \leq 100 \text{ Hz}$ (fluorescent lamps)
- Radiant sensitive area $A = 1 \text{ mm}^2$

Case:
Special case, clear plastic DIP 6
Dimensions see page 63 Fig. 103

U 143 M • Driver circuit for LED digits in TV program displays

Supply voltage range	$-V_{DD}$	10.8...13.2 V
Control level Pin 2...6	$-V_{IL}$	4.0...13.2 V
	V_{IH}	-0.3... 1.0 V

Features:

- Display numbers from 1 to 16
- Direct control of LED-digits with $I_o \geq 10 \text{ mA}$
- Input code BCD
- Display BCD + 1
- Pull-up input resistor 50 k Ω
- Separate input for dark switching I_{DS}

Case:
DIP 16
Dimensions see page 63 Fig. 105

Displays:
e.g. TDSR 5110,
TDSR 5150

U 175 M • U 176 M • Pulse generator for flasher circuits

Supply voltage range	V_S	4.75...13.2 V
Frequency	$V_S = 5 \text{ V}$	U 175 M f_o 1.3...5.2 Hz
		U 176 M f_o 0.3...1.3 Hz
Frequency deviation	$V_S = 12 \text{ V}$	U 175 M f_o 5 Hz
		U 176 M f_o 1.25 Hz
Frequency deviation	$V_S = 5 \dots 12 \text{ V}$	U 175 M Δf 0.3 Hz/V
		U 176 M Δf 0.075 Hz/V

Features:

- Small dimensions
- $P_V = 150 \text{ mW}$ at $T_{amb} = 75 \text{ }^\circ\text{C}$

Case: TO 92 • Dimensions see page 64 Fig. 110

LED: e.g. TLUR 5400

Display Drivers

T-52-13-07

U 237 BG · U 244 B · U 247 BG · U 254 B · U 257 BG · U 267 BG · Driver for LED displays with 5 or 10 diodes

Supply voltage range	Pin 8	V_S	12...25	V
Output current (in series)	Pin 6	I_O	20	mA
Input threshold distance	Pin 7	ΔV_I	$\leq \pm 30$	mV

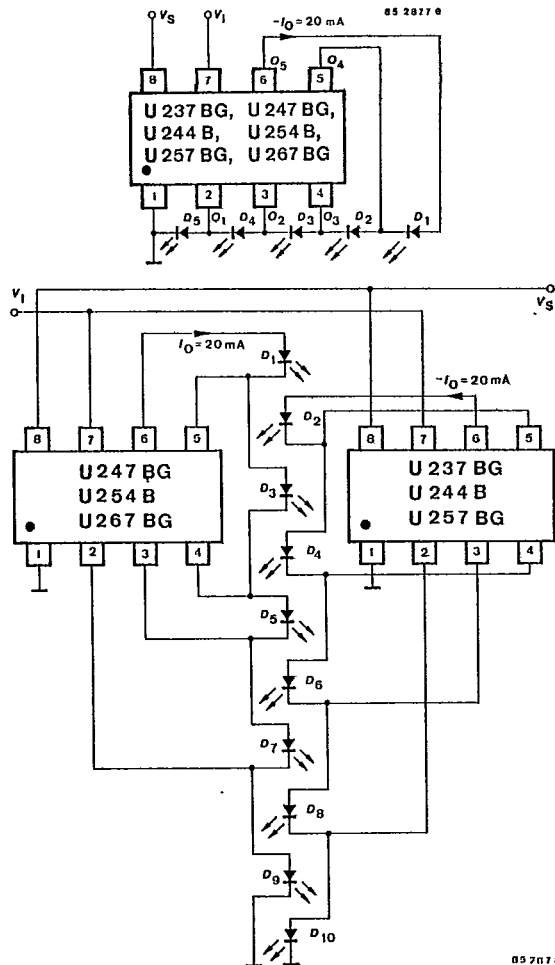

Features:

- Wide supply voltage range
- High LED current
- Low power dissipation due to series connection of LED's
- Different colour LED's can be connected arbitrary
- No peripheral components are necessary
- High input resistance
- Eligible between:
 - 5 LED's line with linear scale division with U 237 BG or U 247 BG
 - 5 LED's line having linear scale division with U 244 B or U 254 B of flowing transition
 - 5 LED's line with logarithmic scale division with U 257 BG or U 276 BG
 - 10 LED's line with linear scale division with U 237 BG and U 247 BG
 - 10 LED's line having linear scale division with U 244 B and U 254 B of flowing transition
 - 10 LED's line with logarithmic scale division with U 257 BG and U 267 BG

Case:

DIP 8
 Dimensions see page 63
 Fig. 104
 LEDs: e.g. TLSH 5100

U 427 B · U 428 B-FP · Driver for IR transmitter diodes

Supply voltage range	V_S	5...10	V	
Control range	V_I	3...10	V	
Control current $\frac{I_p}{T} \leq 0.013$	I_i	<0.1	mA	
Controlled output current pulse	U 427 B U 428 B-FP	I_c I_c	1.3 0.75	A A

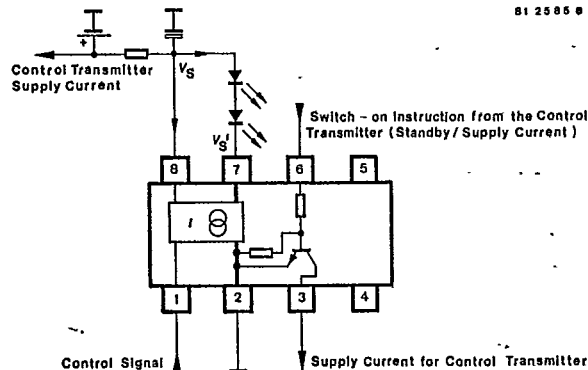

Features:

- Current stabilisation starts at 1.2 V
- Additional switching transistor $I_c = 20$ mA
- Automatic current control

Case:

DIP 8 (U 427 B)
 Dimensions see page 63
 Fig. 104
 or
 SO 8 (U 428 B-FP)
 Dimensions see page 64
 Fig. 111

IREDS: e.g. TSIP 5200



Display Drivers

T-52-13-07

U 429 B-FP · U 430 B-FP · Driver for IR transmitter diodes

Supply voltage range	V_{S1}	2.8...13.2	V
Control range	V_i	2.5...13.2	V
Control current	i_i	0.25	mA
Controlled output current pulse	$I_{O(IR)}$	320	mA

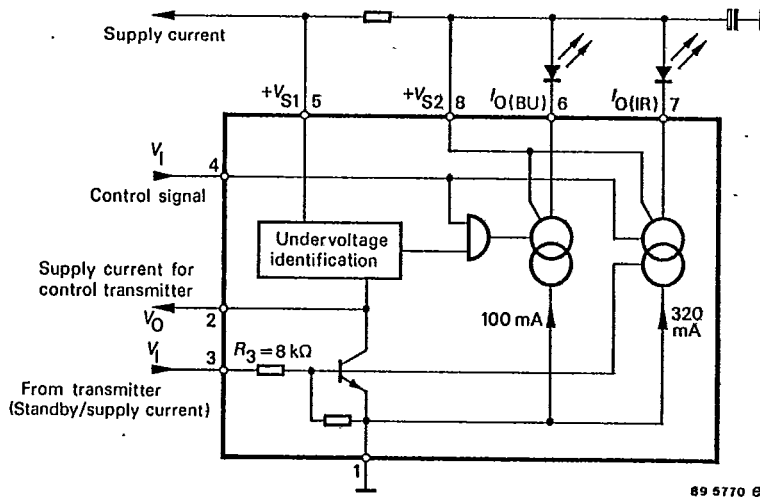

Features:

- Constant current for IR signal 320 mA
- Undervoltage control with indicator driver
- Constant current output for control LED 100 mA
- Current stabilisation starts at $V_{CE} = 1V$
- Control voltage $V_4 = 2...13.2V$
- Minimum driver current $I_4 = 0.4A$
- Additional switching transistor $I_C = 20mA$

Case:

SO 8
Dimensions see page 64
Fig. 111

LED: e.g. TLUR 4400

IRE: e.g. TSIP 5200

U 1096 B · U 2097 B · Driver for 30-element flying spot LED displays

Supply voltage range	Pin 10	V_S	8...16	V
Input voltage range	Pin 16	V_i	0...(V_S-1)	V
Difference of input threshold voltages	Pin 16	ΔV_i	100...500	mV

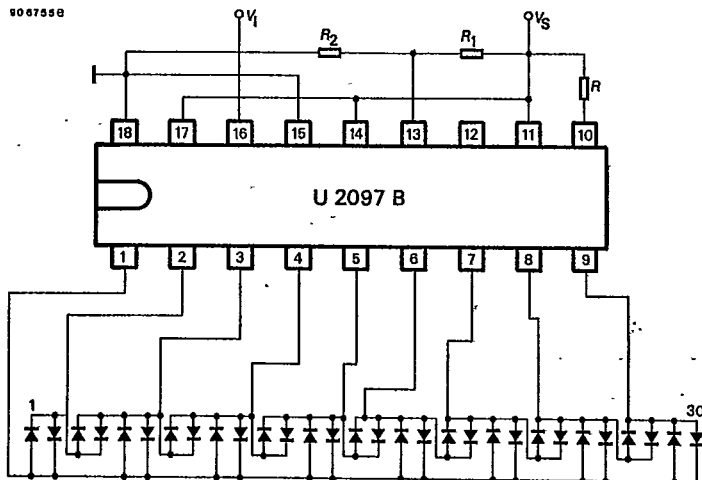

Features:

- Only 9 address lines for 30 LED's "TELEPAREL"
- Up to 150 LED's can be driven by arranging several IC's in a series
- LED's of various colours can be incorporated in displays
- 15 mA current source (U 1096 B)
- External adjustable LED current up to 30 mA (U 2097 B)
- Analogue voltage input
- Regulated indicating range
- Simple voltage ratio indication

Case:

DIP 18
Dimensions see page 63
Fig. 106

LEDs: e.g. TLSH 5100

Display Drivers

T-52-13-07

U 2066 B · U 2067 B · Low cost stereo LED scale controller for radio, amplifier or cassette recorder

Supply voltage range	Pin 16	V_S	7...18	V
Total supply current	Pin 16	I_S	35	mA
LED current source		I_o	15	mA

Features:

- Wide supply voltage range
- Constant LED current
- Low power dissipation due to series connection of LEDs
- Different colour LEDs can be mixed easily
- One operational amplifier per channel
- Logarithmic scale division
- Threshold intervals:
5 dB - 5 dB - 3 dB - 3 dB (U 2066 B)
2 dB - 2 dB - 2 dB - 2 dB (U 2067 B)

Case:

DIP 16
Dimensions see page 63
Number 105

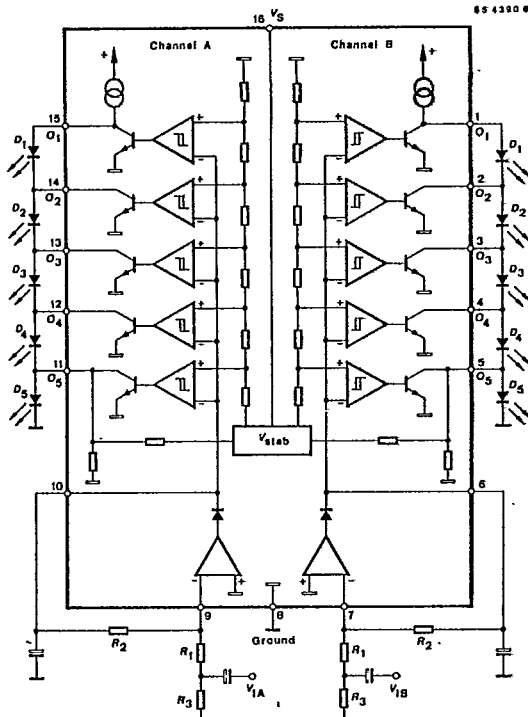

LEDs: e.g. TLS. 5100

Channel B

- LED-Output O₁
- LED-Output O₂
- LED-Output O₃
- LED-Output O₄
- LED-Output O₅
- Rectifier output
- OP AMP "negative"-Input
- Ground (GND)

Channel A

- OP AMP "negative"-Input
- Rectifier output
- LED-Output O₅
- LED-Output O₄
- LED-Output O₃
- LED-Output O₂
- LED-Output O₁
- Supply voltage V_S

Block diagram and pin connections

U 2068 B · Stereo volume indicator for 2 x 5 LEDs and two headphone amplifiers for radio and cassette recorder

Supply voltage range	Pin 20	V_S	7...18	V
Total supply current	Pin 20	I_S	40	mA
LED current source		I_o	15	mA

Features:

- Large supply voltage range
- Constant LED current
- Low power dissipation due to series connection of LEDs
- Different colour LEDs can be mixed easily
- One independent connectable operational amplifier per channel
- Logarithmic scale division with intervals:
6 dB - 6 dB - 3 dB - 3 dB

Case:

DIP 20
Dimensions see page 63
Fig. 107

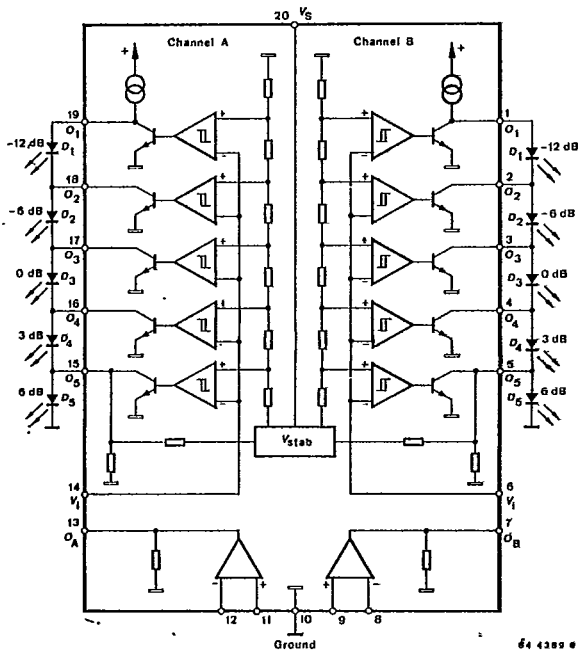

LEDs: e.g. TLS. 5100

Channel B

- LED-Output O₁
- LED-Output O₂
- LED-Output O₃
- LED-Output O₄
- LED-Output O₅
- Comparator input V_i
- OP AMP-Output OUT
- OP AMP "negative"-Input
- OP AMP "positive"-Input
- Ground (GND)

Channel A

- OP AMP "positive"-Input
- OP AMP "negative"-Input
- OP AMP-Output OUT
- Comparator input V_i
- LED-Output O₅
- LED-Output O₄
- LED-Output O₃
- LED-Output O₂
- LED-Output O₁
- Supply voltage V_S

Block diagram and pin connections



Display Drivers

T-52-13-07

Survey – Display drivers

U 3088 M U 3088 M-FP U 3089 M	U 3081 M U 3081 M-FP	U 3082 M	U 3084 M U 3084 M-FP U 3085 M	U 3079 M
Uncoded serial data input				
8 outputs open drain	15 outputs open drain	19 outputs open drain	19 outputs open drain	34 outputs curr. sink
Clear input				Brightness CTR. input
Cascadable				
Wired OR				
U 3089 M: Masc option with pull-up resistors			U 3085 M: Masc option with pull-up resistors	
NCMOS		NMOS	NCMOS	

U 3088 M · U 3088 M-FP · U 3089 M · Microcomputer controlled display drivers with 8 outputs

Supply voltage range	V_S	4.5...5.5	V
Quiescent supply current	I_S	100	μA
Output voltage ($A_1 \dots A_8$) $I_{OL} = 15 \text{ mA}$	V_{OL}	≤ 1	V

Features:

- 8 buffered uncoded outputs, open drain, 15 mA each
- Cascadable through separate shifting register output
- Static drive of LEDs with common anode
- Serial data interface for microcomputer control
- Pull-up resistor at the inputs as a mask option (U 3089 M)

Case:

DIP 16 (U 3088 M, U 3089 M)
Dimensions see page 63
Fig. 105
or
SO 16 (U 3088 M-FP)
Dimensions see page 65
Fig. 112

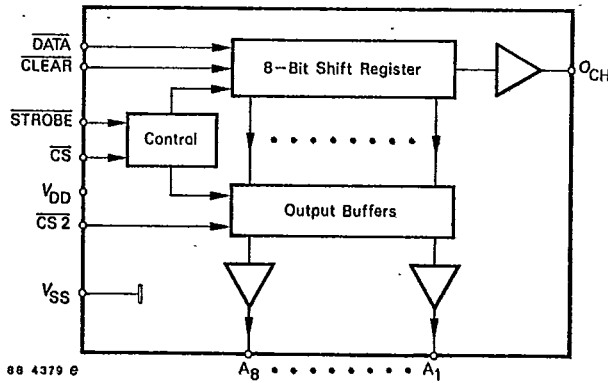

88 4379 0

U 3081 M · U 3081 M-FP · Microcomputer controlled display drivers with 15 outputs

Supply voltage range	V_S	4.5...5.5	V
Quiescent supply current	I_S	200	μA
Output voltage ($A_1 \dots A_{15}$) $I_{OL} = 15 \text{ mA}$	V_{OL}	≤ 1	V

Features:

- 15 buffered uncoded outputs, open drain 15 mA
- Static drive of LEDs with common anode
- Serial data interface for microcomputer control

Case:

DIP 20 (U 3081 M)
Dimensions see page 63
Fig. 107
or
SO 20 (U 3081 M-FP)
Dimensions see page 65
Fig. 113

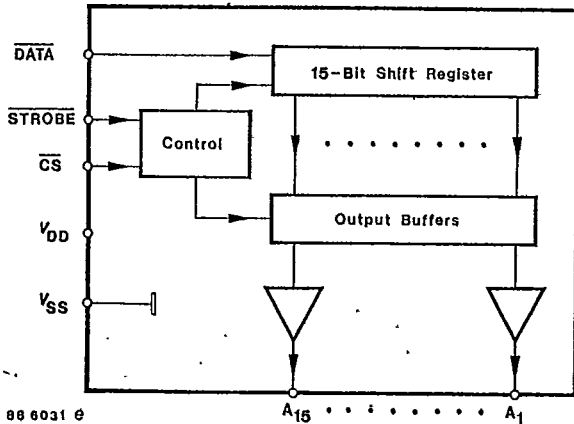

88 6031 0

Display Drivers

T-52-13-07

U 3082 M • Microcomputer controlled display drivers with 19 outputs

Supply voltage range	V_S	10.8...13.2	V
Quiescent supply current	I_S	6	mA
Output voltage ($A_1 \dots A_{19}$) $I_{OL} = 15 \text{ mA}$	V_{OL}	≤ 1	V

- Features:**
- 19 buffered unencoded outputs, open drain 15 mA each
 - Static drive of LED indicators with common anode
 - Serial data interface for microcomputer control

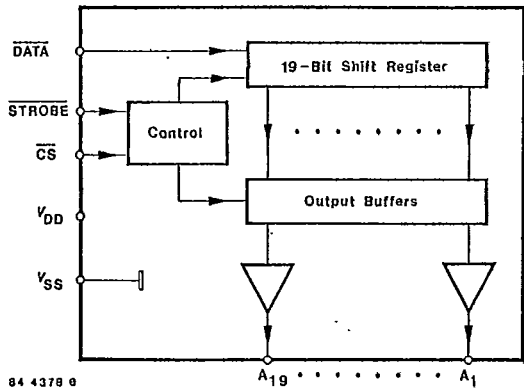

Case:
DIP 24
Dimensions see page 64
Fig. 108

U 3084 M • U 3084 M-FP • U 3085 M • Microcomputer controlled display drivers with 19 outputs

Supply voltage range	V_S	4.5...5.5	V
Quiescent supply current	I_S	200	μA
Output voltage ($A_1 \dots A_{19}$) $I_{OL} = 15 \text{ mA}$	V_{OL}	≤ 1	V

- Features:**
- 19 buffered unencoded outputs, open drain 15 mA each
 - Static drive of LEDs with common anode
 - Serial data interface for microcomputer control
 - Pull-up resistor at the inputs as a mask option (U 3085 M)
 - C-MOS version of U 3082 M

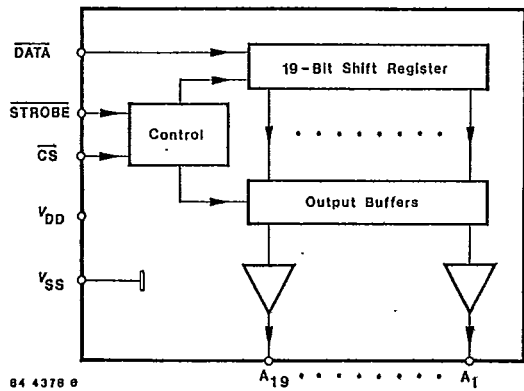

Case:
DIP 24 (U 3084 M, U 3085 M)
Dimensions see page 64
Fig. 108
or
SO 24 (U 3084 M-FP)
Dimensions see page 65
Fig. 114

U 3079 M • T 3079 M • Microcomputer controlled display drivers with 34 outputs

Supply voltage range	V_S	4.5...5.5	V
Quiescent supply current	I_S	2.5	mA

- Features:**
- 34 buffered, unencoded outputs
 - Current generator outputs, typ. 8 mA sink each
 - Static drive of LED-displays with common anode
 - Serial data-interface for software-controlled matching to microcomputers
 - Continuous brightness control
 - Data enable

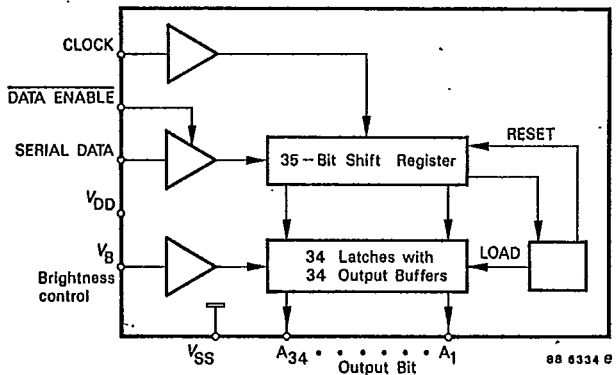

Case:
DIP 40 (U 3079 M)
Dimensions see page 64
Fig. 109
or
Chip for hybrid construction (T 3079 M)

