

RoHS compliant

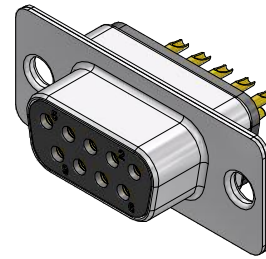
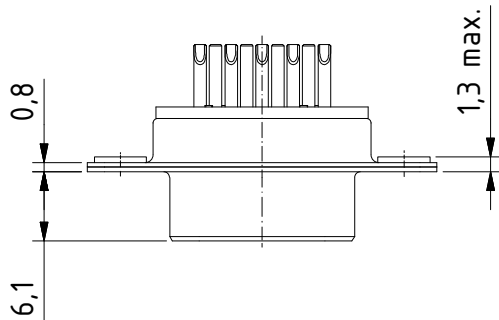
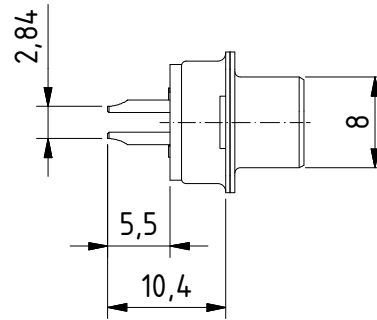
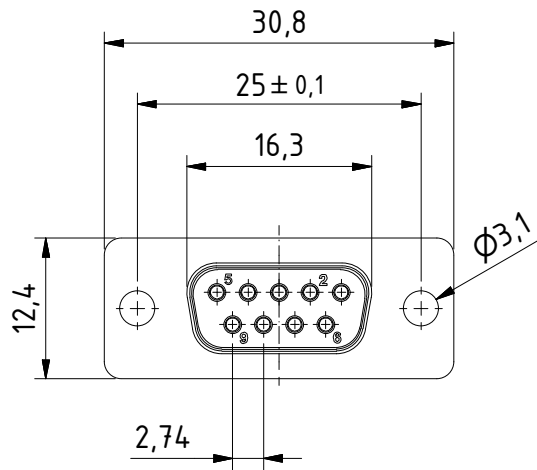

suitable for cable AWG 22

Capacitor value 1'000 pF

MATERIALS

- Insulator: Thermoplastic UL 94-V-0 black
- Contact: Copper alloy
- Contact finish: Quality class 2
- Shell: steel tin plated

CHARAKTERISTICS

- Working voltage: 100V
- Current rating: 5A
- Contact resistance: max. 10mΩ - DIN41652
- Insulation resistance: >1GΩ
- Temperature range: -55° to +125°C

General tolerances (Deltron standard)			
size in mm	> 0.5 up to 3	> 3 up to 6	> 6 up to 30
tolerances	±0.1	±0.2	±0.2
			±0.3

modification	Rev. a) 17.03.1998 mr	Rev. b) 08.03.1999 mr	Rev.	DE002747 part no.		
	Rev.	Rev.	Rev.			
D09SZ/2FP102	1.5:1 scale	drawn	08.09.1997	mr		
		checked				
		approved				
 Industrie Neuhof 8c CH-3422 Kirchberg			K052004 b drawing no.			