

LM137/LM337 3-Terminal Adjustable Negative Regulators

General Description

The LM137/LM337 are adjustable 3-terminal negative voltage regulators capable of supplying in excess of $-1.5A$ over an output voltage range of $-1.2V$ to $-37V$. These regulators are exceptionally easy to apply, requiring only 2 external resistors to set the output voltage and 1 output capacitor for frequency compensation. The circuit design has been optimized for excellent regulation and low thermal transients. Further, the LM137 series features internal current limiting, thermal shutdown and safe-area compensation, making them virtually blowout-proof against overloads.

The LM137/LM337 serve a wide variety of applications including local on-card regulation, programmable-output voltage regulation or precision current regulation. The LM137/LM337 are ideal complements to the LM117/LM317 adjustable positive regulators.

Features

- Output voltage adjustable from $-1.2V$ to $-37V$
- 1.5A output current guaranteed, $-55^{\circ}C$ to $+150^{\circ}C$
- Line regulation typically 0.01%/V
- Load regulation typically 0.3%
- Excellent thermal regulation, 0.002%/W

- 77 dB ripple rejection
- Excellent rejection of thermal transients
- 50 ppm/ $^{\circ}C$ temperature coefficient
- Temperature-independent current limit
- Internal thermal overload protection
- P+ Product Enhancement tested
- Standard 3-lead transistor package
- Output is short circuit protected

LM137 Series Packages and Power Capability

Device	Package	Rated Power Dissipation	Design Load Current
LM137/337	TO-3 (K)	20W	1.5A
	TO-39 (H)	2W	0.5A
LM337	TO-220 (T)	15W	1.5A
LM337M	TO-202 (P)	7.5W	0.5A

Typical Applications

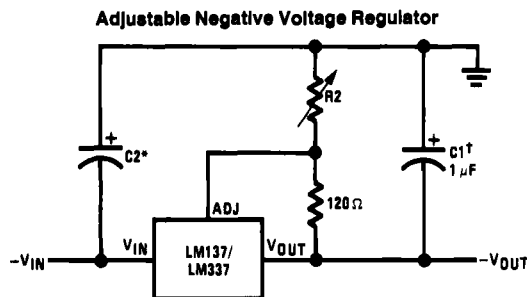

TL/H/9087-1

Full output current not available at high input-output voltages

$$-V_{OUT} = -1.25V \left(1 + \frac{R_2}{120\Omega} \right) + (-I_{ADJ} \times R_2)$$

†C1 = 1 μF solid tantalum or 10 μF aluminum electrolytic required for stability

*C2 = 1 μF solid tantalum is required only if regulator is more than 4" from power-supply filter capacitor

Output capacitors in the range of 1 μF to 1000 μF of aluminum or tantalum electrolytic are commonly used to provide improved output impedance and rejection of transients

Absolute Maximum Ratings

If Military/Aerospace specified devices are required, please contact the National Semiconductor Sales Office/Distributors for availability and specifications. (Note 4)

Power Dissipation	Internally Limited
Input-Output Voltage Differential	40V

Operating Junction Temperature Range	
LM137	-55°C to +150°C
LM337	0°C to +125°C
Storage Temperature	
	-65°C to +150°C
Lead Temperature (Soldering, 10 sec.)	
	300°C
Plastic Package (Soldering, 4 sec.)	
	260°C
ESD Rating	
	2k Volts

Electrical Characteristics (Note 1)

Parameter	Conditions	LM137			LM337			Units
		Min	Typ	Max	Min	Typ	Max	
Line Regulation	$T_j = 25^\circ\text{C}$, $3\text{V} \leq V_{\text{IN}} - V_{\text{OUT}} \leq 40\text{V}$ (Note 2) $I_L = 10\text{mA}$		0.01	0.02		0.01	0.04	%/V
Load Regulation	$T_j = 25^\circ\text{C}$, $10\text{mA} \leq I_{\text{OUT}} \leq I_{\text{MAX}}$		0.3	0.5		0.3	1.0	%
Thermal Regulation	$T_j = 25^\circ\text{C}$, 10 ms Pulse		0.002	0.02		0.003	0.04	%/W
Adjustment Pin Current			65	100		65	100	μA
Adjustment Pin Current Charge	$10\text{mA} \leq I_L \leq I_{\text{MAX}}$ $3.0\text{V} \leq V_{\text{IN}} - V_{\text{OUT}} \leq 40\text{V}$, $T_A = 25^\circ\text{C}$		2	5		2	5	μA
Reference Voltage	$T_j = 25^\circ\text{C}$ (Note 3) $3\text{V} \leq V_{\text{IN}} - V_{\text{OUT}} \leq 40\text{V}$, (Note 3) $10\text{mA} \leq I_{\text{OUT}} \leq I_{\text{MAX}}$, $P \leq P_{\text{MAX}}$	-1.225	-1.250	-1.275	-1.213	-1.250	-1.287	V
		-1.200	-1.250	-1.300	-1.200	-1.250	-1.300	V
Line Regulation	$3\text{V} \leq V_{\text{IN}} - V_{\text{OUT}} \leq 40\text{V}$, (Note 2)		0.02	0.05		0.02	0.07	%/V
Load Regulation	$10\text{mA} \leq I_{\text{OUT}} \leq I_{\text{MAX}}$, (Note 2)		0.3	1		0.3	1.5	%
Temperature Stability	$T_{\text{MIN}} \leq T_j \leq T_{\text{MAX}}$		0.6			0.6		%
Minimum Load Current	$ V_{\text{IN}} - V_{\text{OUT}} \leq 40\text{V}$ $ V_{\text{IN}} - V_{\text{OUT}} \leq 10\text{V}$		2.5	5		2.5	10	mA
			1.2	3		1.5	6	mA
Current Limit	$ V_{\text{IN}} - V_{\text{OUT}} \leq 15\text{V}$ K and T Package H and P Package $ V_{\text{IN}} - V_{\text{OUT}} = 40\text{V}$, $T_j = 25^\circ\text{C}$ K and T Package H and P Package	1.5	2.2	3.5	1.5	2.2	3.7	A
		0.5	0.8	1.8	0.5	0.8	1.9	A
		0.24	0.4		0.15	0.4		A
		0.15	0.17		0.10	0.17		A
RMS Output Noise, % of V_{OUT}	$T_j = 25^\circ\text{C}$, $10\text{Hz} \leq f \leq 10\text{kHz}$		0.003			0.003		%
Ripple Rejection Ratio	$V_{\text{OUT}} = -10\text{V}$, $f = 120\text{Hz}$ $C_{\text{ADJ}} = 10\mu\text{F}$		60			60		dB
			66	77		66	77	dB
Long-Term Stability	$T_j = 125^\circ\text{C}$, 1000 Hours		0.3	1		0.3	1	%
Thermal Resistance, Junction to Case	H Package		12	15		12	15	$^\circ\text{C}/\text{W}$
	K Package		2.3	3		2.3	3	$^\circ\text{C}/\text{W}$
	T Package					4		$^\circ\text{C}/\text{W}$
	P Package					7		$^\circ\text{C}/\text{W}$
Thermal Resistance, Junction to Ambient (No Heat Sink)	H Package		140			140		$^\circ\text{C}/\text{W}$
	K Package		35			35		$^\circ\text{C}/\text{W}$
	T Package					50		$^\circ\text{C}/\text{W}$
	P Package					80		$^\circ\text{C}/\text{W}$

Note 1: Unless otherwise specified, these specifications apply $-55^\circ\text{C} \leq T_j \leq +150^\circ\text{C}$ for the LM137, $0^\circ\text{C} \leq T_j \leq +125^\circ\text{C}$ for the LM337; $V_{\text{IN}} - V_{\text{OUT}} = 5\text{V}$; and $I_{\text{OUT}} = 0.1\text{A}$ for the TO-39 and TO-202 packages and $I_{\text{OUT}} = 0.5\text{A}$ for the TO-3 and TO-220 packages. Although power dissipation is internally limited, these specifications are applicable for power dissipations of 2W for the TO-39 and TO-202 and 20W for the TO-3 and TO-220. I_{MAX} is 1.5A for the TO-3 and TO-220 packages, and 0.5A for the TO-202 package and 0.2A for the TO-39 package.

Note 2: Regulation is measured at constant junction temperature, using pulse testing with a low duty cycle. Changes in output voltage due to heating effects are covered under the specification for thermal regulation. Load regulation is measured on the output pin at a point $1/8"$ below the base of the TO-3 and TO-39 packages.

Note 3: Selected devices with tightened tolerance reference voltage available.

Note 4: Refer to RETS137H drawing for LM137H or RETS137K drawing for LM137K military specifications.

Schematic Diagram

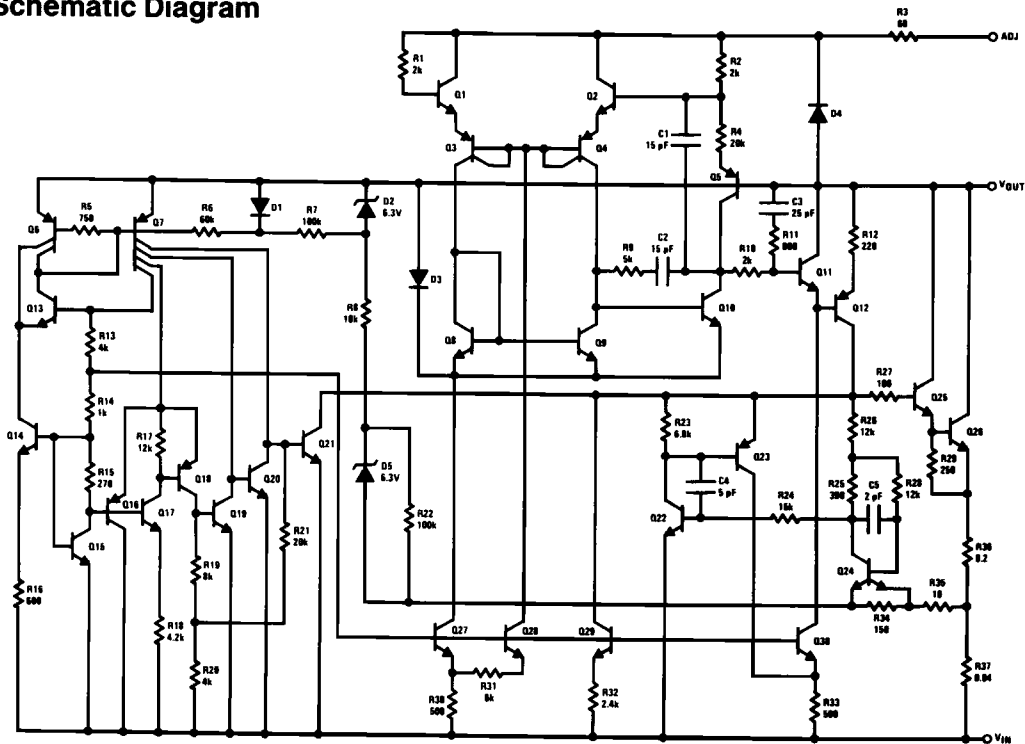

TL/H/9067-2

Thermal Regulation

When power is dissipated in an IC, a temperature gradient occurs across the IC chip affecting the individual IC circuit components. With an IC regulator, this gradient can be especially severe since power dissipation is large. Thermal regulation is the effect of these temperature gradients on output voltage (in percentage output change) per Watt of power change in a specified time. Thermal regulation error is independent of electrical regulation or temperature coefficient, and occurs within 5 ms to 50 ms after a change in power dissipation. Thermal regulation depends on IC layout as well as electrical design. The thermal regulation of a voltage regulator is defined as the percentage change of V_{OUT} , per Watt, within the first 10 ms after a step of power is applied. The LM137's specification is 0.02%/W, max.

In *Figure 1*, a typical LM137's output drifts only 3 mV (or 0.03% of $V_{OUT} = -10V$) when a 10W pulse is applied for 10 ms. This performance is thus well inside the specification limit of $0.02\%/W \times 10W = 0.2\%$ max. When the 10W pulse is ended, the thermal regulation again shows a 3 mV step at the LM137 chip cools off. Note that the load regulation error of about 8 mV (0.08%) is additional to the thermal regulation error. In *Figure 2*, when the 10W pulse is applied for 100 ms, and the thermal error stays well within 0.1% (10 mV).

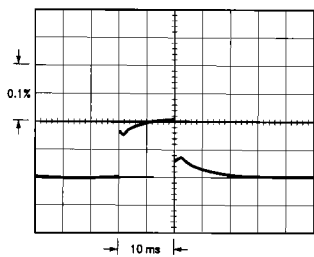

TL/H/9067-3

LM137, $V_{OUT} = -10V$
 $V_{IN} - V_{OUT} = -40V$
 $I_L = 0A \rightarrow 0.25A \rightarrow 0A$
 Vertical sensitivity, 5 mV/div

FIGURE 1

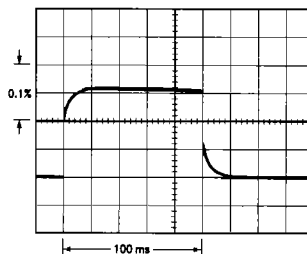

TL/H/9067-4

LM137, $V_{OUT} = -10V$
 $V_{IN} - V_{OUT} = -40V$
 $I_L = 0A \rightarrow 0.25A \rightarrow 0A$
 Horizontal sensitivity, 20 ms/div

FIGURE 2

Connection Diagrams

**TO-3
Metal Can Package**

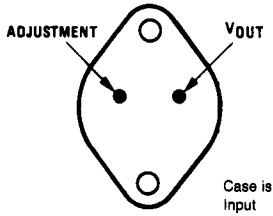

TL/H/9087-5

Bottom View

**Order Number LM137K STEEL or LM337K STEEL
See NS Package Number K02A**

**TO-39
Metal Can Package**

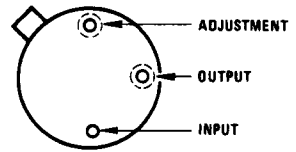

TL/H/9087-6

Bottom View

**Order Number LM137H or LM337H
See NS Package Number H03A**

**TO-220
Plastic Package**

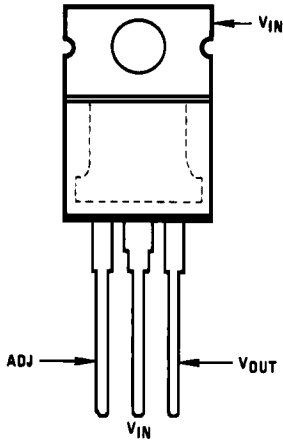

TL/H/9087-7

Front View

**Order Number LM337T
See NS Package Number T03B**

**TO-202
Plastic Package**

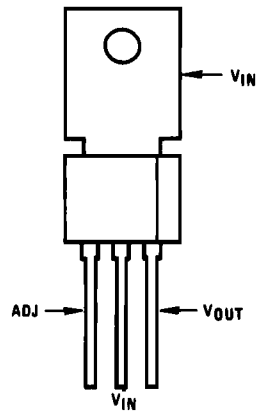

TL/H/9087-8

Front View

**Order Number LM337MP
See NS Package Number P03A**

Typical Applications (Continued)

Adjustable Lab Voltage Regulator

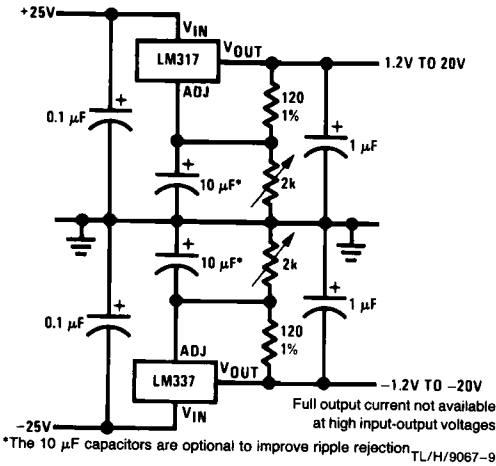

-5.2V Regulator with Electronic Shutdown*

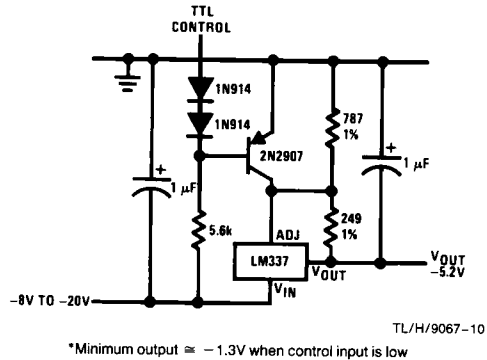

Current Regulator

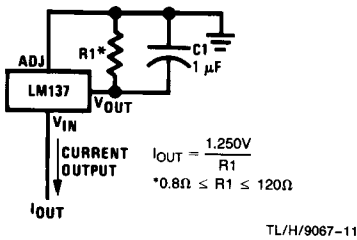

Adjustable Current Regulator

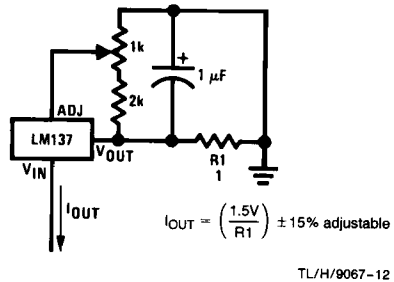

Negative Regulator with Protection Diodes

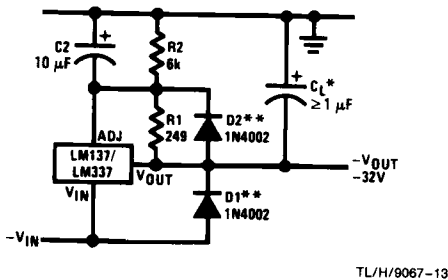

*When C1 is larger than 20 μF, D1 protects the LM137 in case the input supply is shorted

**When C2 is larger than 10 μF and -VOUT is larger than -25V, D2 protects the LM137 in case the output is shorted

High Stability - 10V Regulator

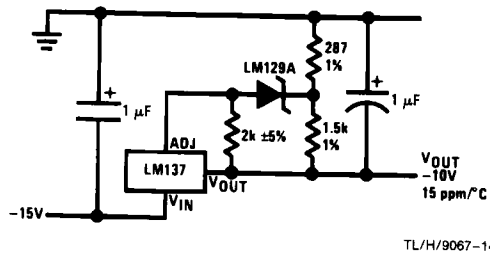

Typical Performance Characteristics (K Steel and T Packages)

