

NPN 8 GHz wideband transistor

 BFG65

N AMER PHILIPS/DISCRETE

69E D

DESCRIPTION

NPN transistor in a four-lead dual emitter plastic envelope (SOT103). It is designed for wideband application in the GHz range, such as satellite TV systems and repeater amplifiers in fibre-optical systems. The device features a very high transition frequency, high gain and a very low noise figure up to 2 GHz.

PINNING

PIN	DESCRIPTION
1	emitter
2	collector
3	emitter
4	base

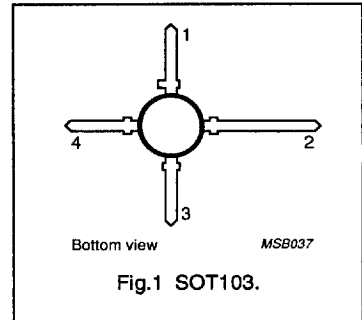

QUICK REFERENCE DATA

SYMBOL	PARAMETER	CONDITIONS	MIN.	TYP.	MAX.	UNIT
V_{CBO}	collector-base voltage	open emitter	–	–	20	V
V_{CEO}	collector-emitter voltage	open base	–	–	10	V
I_C	DC collector current		–	–	50	mA
P_{tot}	total power dissipation	up to $T_s = 158^\circ\text{C}$ (note 1)	–	–	300	mW
T_j	junction temperature		–	–	175	$^\circ\text{C}$
h_{FE}	DC current gain	$I_C = 15\text{ mA}$; $V_{CE} = 5\text{ V}$	60	100	–	
f_T	transition frequency	$I_C = 15\text{ mA}$; $V_{CE} = 8\text{ V}$; $f = 500\text{ MHz}$	–	8	–	GHz
G_{UM}	maximum unilateral power gain	$I_C = 15\text{ mA}$; $V_{CE} = 8\text{ V}$; $f = 2\text{ GHz}$	–	10.5	–	dB
F	noise figure at optimum source impedance	$Z_S = 50\ \Omega$; $I_C = 15\text{ mA}$; $V_{CE} = 8\text{ V}$; $f = 1\text{ GHz}$	–	1.7	–	dB

LIMITING VALUES

In accordance with the Absolute Maximum System (IEC 134).

SYMBOL	PARAMETER	CONDITIONS	MIN.	MAX.	UNIT
V_{CBO}	collector-base voltage	open emitter	–	20	V
V_{CEO}	collector-emitter voltage	open base	–	10	V
V_{EBO}	emitter-base voltage	open collector	–	2.5	V
I_C	DC collector current		–	50	mA
P_{tot}	total power dissipation	up to $T_s = 158^\circ\text{C}$ (note 1)	–	300	mW
T_{stg}	storage temperature range		–65	150	$^\circ\text{C}$
T_j	junction temperature		–	175	$^\circ\text{C}$

Note

- T_s is the temperature at the soldering point of the collector lead.

NPN 8 GHz wideband transistor

BFG65

N AMER PHILIPS/DISCRETE

69E D -

THERMAL RESISTANCE

SYMBOL	PARAMETER	THERMAL RESISTANCE
$R_{th\ j-s}$	from junction to soldering point	55 K/W

CHARACTERISTICS

 $T_j = 25\text{ }^\circ\text{C}$ unless otherwise specified.

SYMBOL	PARAMETER	CONDITIONS	MIN.	TYP.	MAX.	UNIT
I_{CBO}	collector cut-off current	$I_E = 0; V_{CB} = 5\text{ V}$	–	–	50	nA
h_{FE}	DC current gain	$I_C = 15\text{ mA}; V_{CE} = 5\text{ V}$	60	100	–	
f_T	transition frequency	$I_C = 15\text{ mA}; V_{CE} = 8\text{ V};$ $f = 500\text{ MHz}$	–	8	–	GHz
C_c	collector capacitance	$I_E = I_B = 0; V_{CB} = 8\text{ V};$ $f = 1\text{ MHz}$	–	1.1	–	pF
C_e	emitter capacitance	$I_C = I_B = 0; V_{EB} = 0.5\text{ V};$ $f = 1\text{ MHz}$	–	1.3	–	pF
C_{re}	feedback capacitance	$I_C = 0; V_{CE} = 8\text{ V};$ $f = 1\text{ MHz}$	–	0.5	–	pF
G_{UM}	maximum unilateral power gain (note 1)	$I_C = 15\text{ mA}; V_{CE} = 8\text{ V};$ $T_{amb} = 25\text{ }^\circ\text{C}; f = 800\text{ MHz}$	–	18.5	–	dB
		$I_C = 15\text{ mA}; V_{CE} = 8\text{ V};$ $T_{amb} = 25\text{ }^\circ\text{C}; f = 2\text{ GHz}$	–	10.5	–	dB
F	noise figure at optimum source impedance	$Z_S = 50\ \Omega; I_C = 5\text{ mA}; V_{CE} = 8\text{ V};$ $T_{amb} = 25\text{ }^\circ\text{C}; f = 1\text{ GHz}$	–	1.3	–	dB
		$Z_S = 50\ \Omega; I_C = 15\text{ mA}; V_{CE} = 8\text{ V};$ $T_{amb} = 25\text{ }^\circ\text{C}; f = 1\text{ GHz}$	–	1.7	–	dB
		$Z_S = 50\ \Omega; I_C = 5\text{ mA}; V_{CE} = 8\text{ V};$ $T_{amb} = 25\text{ }^\circ\text{C}; f = 2\text{ GHz}$	–	2.1	–	dB
		$Z_S = 50\ \Omega; I_C = 15\text{ mA}; V_{CE} = 8\text{ V};$ $T_{amb} = 25\text{ }^\circ\text{C}; f = 2\text{ GHz}$	–	2.7	–	dB

Note

1. G_{UM} is the maximum unilateral power gain, assuming S_{12} is zero and $G_{UM} = 10 \log \frac{|S_{21}|^2}{(1 - |S_{11}|^2)(1 - |S_{22}|^2)}$ dB.

NPN 8 GHz wideband transistor

BFG65

N AMER PHILIPS/DISCRETE

69E D

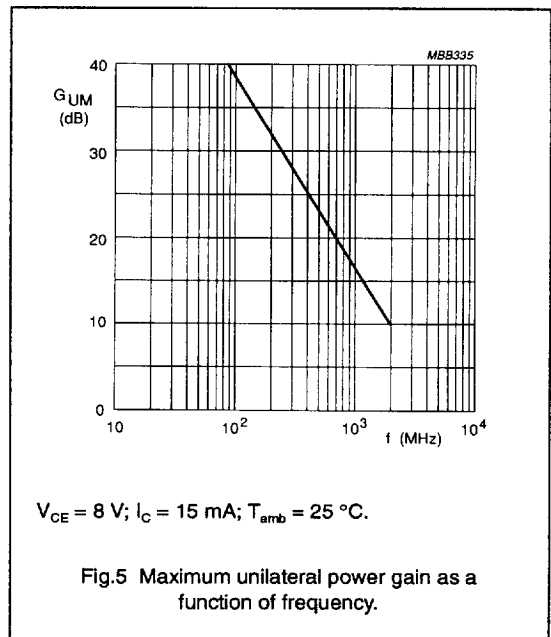
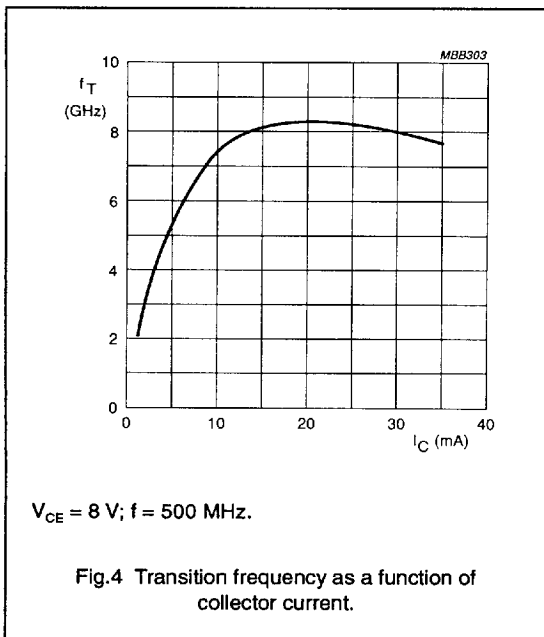
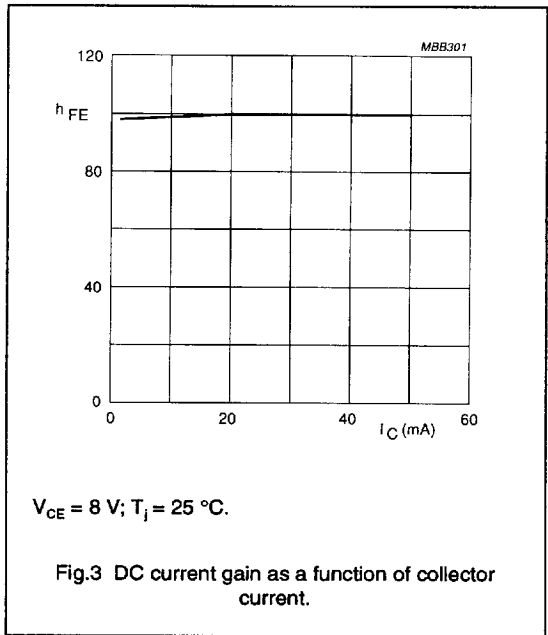
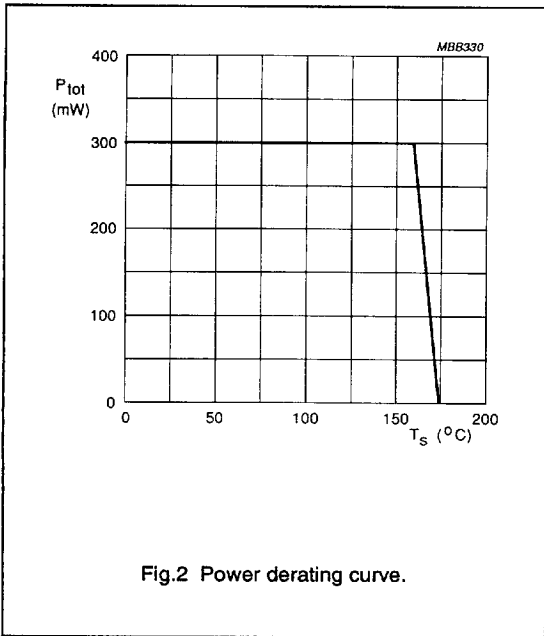

NPN 8 GHz wideband transistor

BFG65

N AMER PHILIPS/DISCRETE

69E D

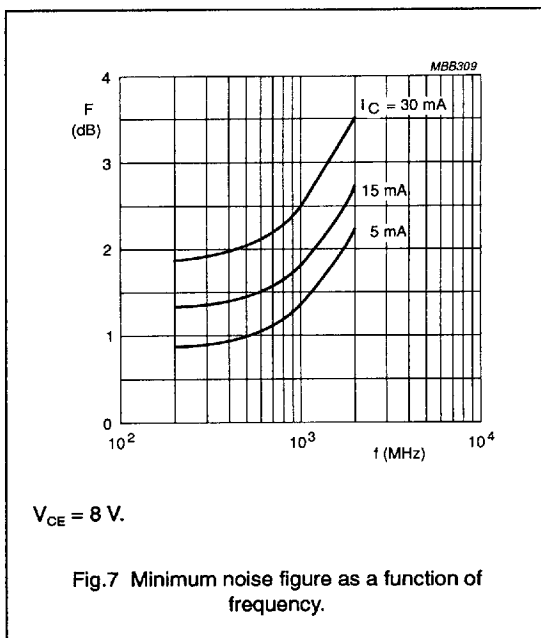
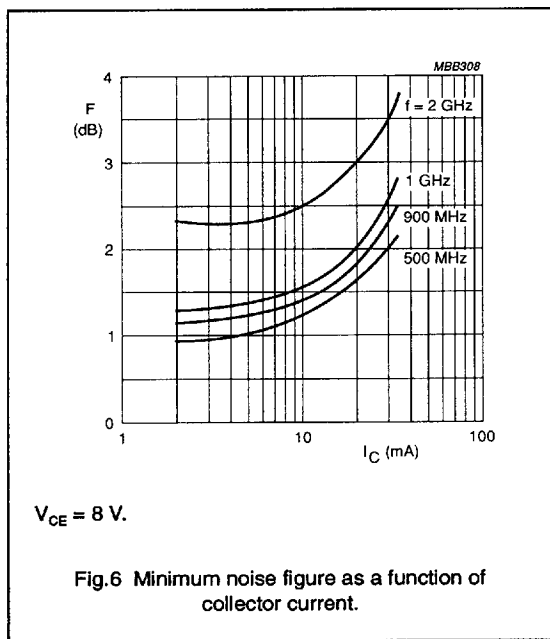

NPN 8 GHz wideband transistor

BFG65

N AMER PHILIPS/DISCRETE

69E D

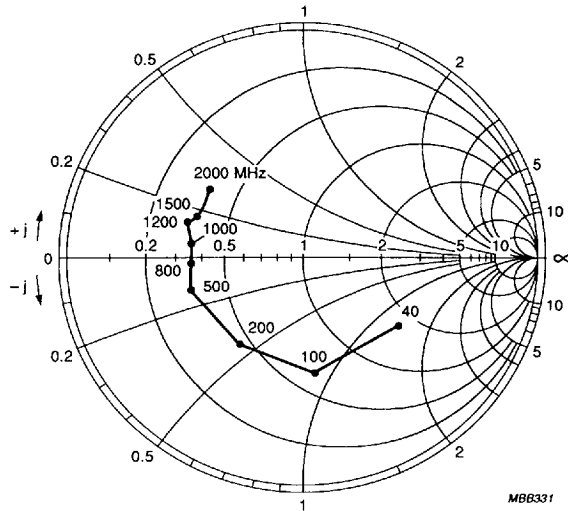

MBB331

$V_{CE} = 8 \text{ V}; I_C = 30 \text{ mA}; T_{amb} = 25 \text{ }^\circ\text{C}.$

Fig.8 Common emitter input reflection coefficient (S_{11}).

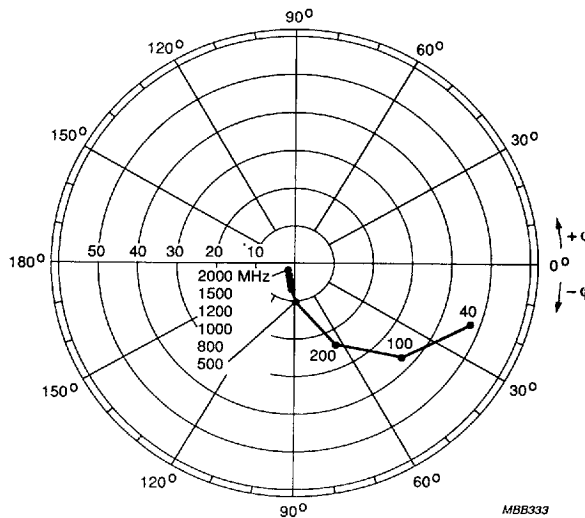

MBB333

$V_{CE} = 8 \text{ V}; I_C = 30 \text{ mA}; T_{amb} = 25 \text{ }^\circ\text{C}.$

Fig.9 Common emitter forward transmission coefficient (S_{21}).

NPN 8 GHz wideband transistor

BFG65

N AMER PHILIPS/DISCRETE

69E D

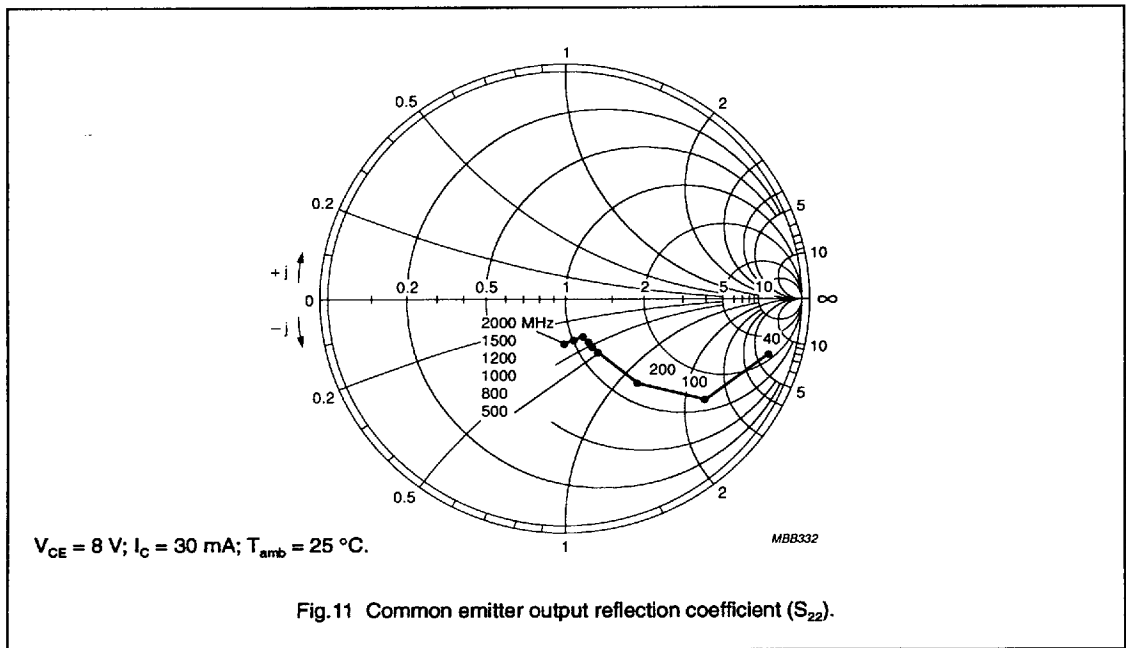
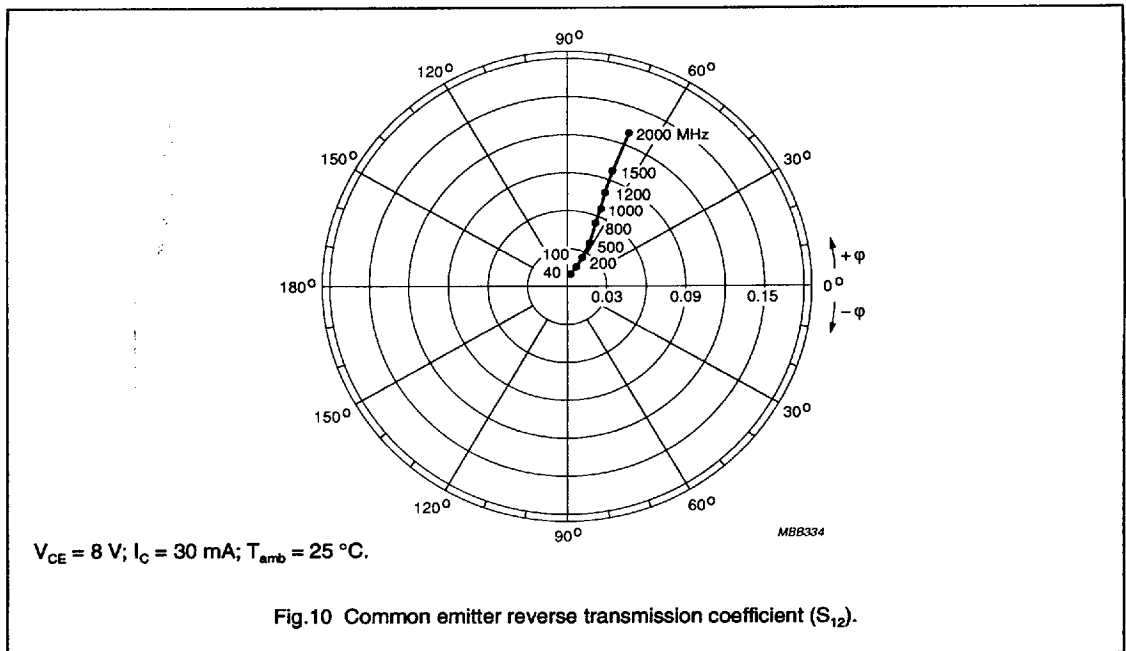

NPN 8 GHz wideband transistor

BFG65

N AMER PHILIPS/DISCRETE

69E D

Table 1 Common emitter scattering parameters, $V_{CE} = 8\text{ V}$, $I_C = 10\text{ mA}$

f (MHz)	S ₁₁		S ₂₁		S ₁₂		S ₂₂		G _{UM} (dB)
	MAG. (RAT)	ANG. (DEG)	MAG. (RAT)	ANG. (DEG)	MAG. (RAT)	ANG. (DEG)	MAG. (RAT)	ANG. (DEG)	
40	0.737	-20.0	26.381	167.0	0.010	79.3	0.968	-10.5	43.8
100	0.700	-47.4	23.940	150.5	0.022	66.7	0.880	-24.6	37.0
200	0.627	-84.5	18.946	129.8	0.036	53.4	0.702	-40.8	30.7
300	0.584	-110.8	14.923	115.9	0.043	46.2	0.563	-50.6	26.9
400	0.567	-128.6	12.112	106.4	0.048	43.2	0.470	-56.6	24.4
500	0.558	-141.7	10.112	98.9	0.052	41.6	0.411	-60.6	22.5
600	0.550	-151.2	8.653	93.1	0.055	41.1	0.371	-63.5	20.9
700	0.542	-159.6	7.515	88.2	0.059	41.6	0.343	-65.2	19.6
800	0.533	-166.2	6.667	84.1	0.062	42.2	0.320	-66.4	18.4
900	0.533	-171.9	5.964	79.9	0.066	42.5	0.302	-67.1	17.4
1000	0.532	-178.0	5.380	76.3	0.069	43.3	0.284	-67.9	16.4
1200	0.535	171.5	4.564	69.2	0.077	43.6	0.256	-72.3	14.9
1400	0.551	162.8	3.934	62.9	0.084	43.6	0.236	-79.7	13.7
1600	0.551	156.2	3.452	57.1	0.092	44.1	0.238	-85.4	12.6
1800	0.552	149.7	3.143	50.8	0.101	43.6	0.245	-89.6	11.8
2000	0.558	142.9	2.848	45.4	0.110	42.2	0.240	-92.6	11.0
2200	0.580	135.9	2.597	40.2	0.119	41.8	0.225	-97.8	10.3
2400	0.602	130.7	2.402	35.7	0.127	40.8	0.217	-107.2	9.8
2600	0.617	127.0	2.229	30.1	0.135	38.8	0.230	-117.1	9.3
2800	0.622	121.6	2.099	24.4	0.143	37.1	0.248	-123.5	8.8
3000	0.623	116.7	1.971	20.1	0.154	36.0	0.256	-126.1	8.3

NPN 8 GHz wideband transistor

BFG65

N AMER PHILIPS/DISCRETE

69E D

Table 2 Common emitter scattering parameters, $V_{CE} = 8\text{ V}$, $I_C = 15\text{ mA}$

f (MHz)	S ₁₁		S ₂₁		S ₁₂		S ₂₂		G _{UM} (dB)
	MAG. (RAT)	ANG. (DEG)	MAG. (RAT)	ANG. (DEG)	MAG. (RAT)	ANG. (DEG)	MAG. (RAT)	ANG. (DEG)	
40	0.653	-25.8	34.244	164.3	0.009	77.1	0.950	-13.2	43.2
100	0.620	-59.5	29.823	145.1	0.020	63.6	0.827	-29.8	36.6
200	0.563	-100.4	21.965	123.5	0.031	52.1	0.616	-46.9	30.6
300	0.541	-125.7	16.612	110.5	0.036	46.6	0.476	-55.9	27.0
400	0.537	-141.4	13.167	101.8	0.041	46.1	0.391	-61.3	24.6
500	0.534	-152.8	10.854	95.2	0.045	45.8	0.340	-64.8	22.7
600	0.532	-161.2	9.223	89.9	0.048	46.6	0.306	-66.9	21.2
700	0.527	-168.0	7.978	85.5	0.053	47.5	0.284	-68.3	19.8
800	0.522	-173.9	7.061	81.7	0.057	48.9	0.265	-69.3	18.7
900	0.523	-179.3	6.308	77.8	0.062	49.1	0.250	-69.8	17.7
1000	0.522	-175.9	5.693	74.4	0.066	49.8	0.236	-70.4	16.7
1200	0.532	-166.2	4.809	67.8	0.074	49.8	0.211	-74.9	15.3
1400	0.545	-158.3	4.141	61.9	0.084	49.2	0.195	-83.3	14.0
1600	0.550	-152.6	3.629	56.2	0.093	49.2	0.200	-89.1	12.9
1800	0.550	-146.6	3.287	50.2	0.103	48.0	0.208	-93.1	12.1
2000	0.558	-139.8	2.987	45.1	0.113	46.2	0.205	-95.9	11.3
2200	0.575	-133.8	2.710	39.8	0.123	45.0	0.191	-101.4	10.6
2400	0.597	-128.4	2.515	35.5	0.131	43.5	0.185	-112.1	10.1
2600	0.615	-125.1	2.326	30.4	0.140	41.3	0.199	-122.5	9.6
2800	0.620	-119.6	2.197	24.3	0.148	39.0	0.218	-128.8	9.2
3000	0.624	-114.6	2.060	20.3	0.159	37.3	0.225	-130.9	8.6

NPN 8 GHz wideband transistor

BFG65

N AMER PHILIPS/DISCRETE

69E D

Table 3 Common emitter scattering parameters, $V_{CE} = 8 \text{ V}$, $I_C = 20 \text{ mA}$

f (MHz)	S_{11}		S_{21}		S_{12}		S_{22}		G_{UM} (dB)
	MAG. (RAT)	ANG. (DEG)	MAG. (RAT)	ANG. (DEG)	MAG. (RAT)	ANG. (DEG)	MAG. (RAT)	ANG. (DEG)	
40	0.586	-31.0	40.395	162.1	0.009	77.1	0.933	-15.3	42.9
100	0.561	-70.0	33.893	141.0	0.019	61.3	0.782	-33.7	36.4
200	0.527	-112.1	23.701	119.4	0.028	51.7	0.556	-50.7	30.5
300	0.521	-135.9	17.482	107.2	0.032	48.3	0.421	-59.2	27.1
400	0.524	-149.8	13.702	99.1	0.037	49.1	0.343	-63.9	24.7
500	0.526	-159.7	11.222	92.9	0.041	50.1	0.297	-67.1	22.8
600	0.528	-167.3	9.485	88.0	0.045	50.7	0.269	-69.0	21.3
700	0.522	-173.2	8.189	83.7	0.050	52.1	0.250	-70.2	19.9
800	0.518	-178.7	7.244	80.1	0.055	53.1	0.234	-70.6	18.8
900	0.520	176.9	6.460	76.5	0.060	53.5	0.221	-71.0	17.8
1000	0.522	171.6	5.822	73.2	0.064	53.7	0.209	-71.6	16.9
1200	0.532	163.2	4.930	66.9	0.074	53.5	0.186	-76.3	15.5
1400	0.545	156.1	4.221	61.1	0.084	52.6	0.172	-85.2	14.2
1600	0.548	150.2	3.702	55.6	0.094	52.0	0.179	-91.4	13.1
1800	0.547	144.5	3.361	49.7	0.105	50.5	0.188	-95.3	12.2
2000	0.557	138.2	3.046	44.6	0.115	48.2	0.185	-98.1	11.4
2200	0.575	132.3	2.775	39.6	0.125	46.8	0.172	-103.7	10.7
2400	0.604	127.3	2.566	35.4	0.134	45.2	0.168	-115.1	10.3
2600	0.609	124.2	2.381	30.1	0.142	42.5	0.183	-126.0	9.7
2800	0.617	119.1	2.239	24.4	0.152	40.1	0.204	-132.0	9.3
3000	0.620	114.1	2.087	20.3	0.162	38.2	0.210	-133.7	8.7