

TC74LVX138F, TC74LVX138FN, TC74LVX138FT

3-TO-8 LINE DECODER

The TC74LVX138 is a high speed CMOS 3-TO-8 LINE DECODER fabricated with silicon gate C²MOS technology. Designed for use in 3.3 Volt systems, it achieves high speed operation while maintaining the CMOS low power dissipation.

This device is suitable for low voltage and battery operated systems.

When the device is enabled, 3 Binary Select inputs (A, B and C) determine which one of the outputs ($\bar{Y}0$ - $\bar{Y}7$) will go low.

When enable input G1 is held low or either $\bar{G}2A$ or $\bar{G}2B$ is held high, decoding function is inhibited and all outputs go high.

G1, $\bar{G}2A$, and $\bar{G}2B$ inputs are provided to ease cascade connection and for use as an address decoder for memory systems.

An input protection circuit ensures that 0 to 7V can be applied to the input pins without regard to the supply voltage.

This device can be used to interface 5V to 3V systems and two supply systems such as battery back up. This circuit prevents device destruction due to mismatched supply and input voltages.

FEATURES

- High speed : $t_{pd} = 5.5ns$ (Typ.) ($V_{CC} = 3.3V$)
- Low power dissipation : $I_{CC} = 4\mu A$ (Max.) ($T_a = 25^\circ C$)
- Input voltage level : $V_{IL} = 0.8V$ (Max.) ($V_{CC} = 3V$)
 $V_{IH} = 2.0V$ (Min.) ($V_{CC} = 3V$)
- Power down protection is provided on all inputs.
- Balanced propagation delays : $t_{pLH} \approx t_{pHL}$
- Low noise : $V_{OLP} = 0.5V$ (Max.)
- Pin and function compatible with 74HC138

(Note) The JEDEC SOP (FN) is not available in Japan.

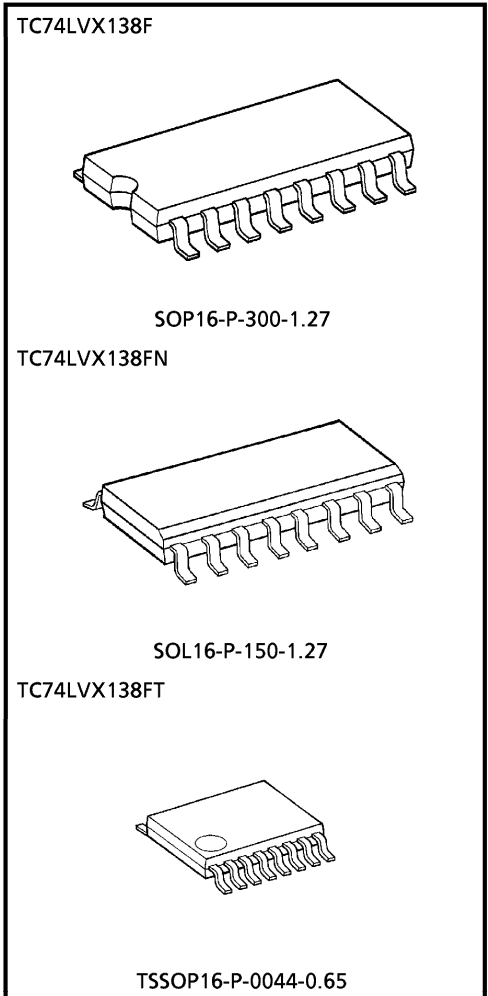

Weight

SOP16-P-300-1.27	: 0.18g (Typ.)
SOL16-P-150-1.27	: 0.12g (Typ.)
TSSOP16-P-0044-0.65	: 0.06g (Typ.)

PIN ASSIGNMENT

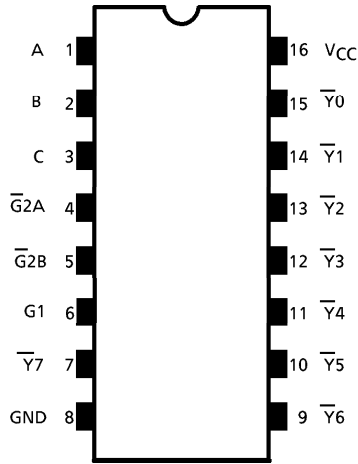

(TOP VIEW)

TRUTH TABLE

INPUTS						OUTPUTS								SELECTED OUTPUT
ENABLE			SELECT			$\bar{Y}0$	$\bar{Y}1$	$\bar{Y}2$	$\bar{Y}3$	$\bar{Y}4$	$\bar{Y}5$	$\bar{Y}6$	$\bar{Y}7$	
G1	$\bar{G}2A$	$\bar{G}2B$	C	B	A									
L	X	X	X	X	X	H	H	H	H	H	H	H	H	NONE
X	H	X	X	X	X	H	H	H	H	H	H	H	H	NONE
X	X	H	X	X	X	H	H	H	H	H	H	H	H	NONE
H	L	L	L	L	L	L	H	H	H	H	H	H	H	$\bar{Y}0$
H	L	L	L	L	H	H	L	H	H	H	H	H	H	$\bar{Y}1$
H	L	L	L	H	L	H	H	L	H	H	H	H	H	$\bar{Y}2$
H	L	L	L	H	H	H	H	H	L	H	H	H	H	$\bar{Y}3$
H	L	L	H	L	L	H	H	H	H	L	H	H	H	$\bar{Y}4$
H	L	L	H	L	H	H	H	H	H	H	L	H	H	$\bar{Y}5$
H	L	L	H	H	L	H	H	H	H	H	H	L	H	$\bar{Y}6$
H	L	L	H	H	H	H	H	H	H	H	H	H	L	$\bar{Y}7$

X : Don't Care

IEC LOGIC SYMBOL

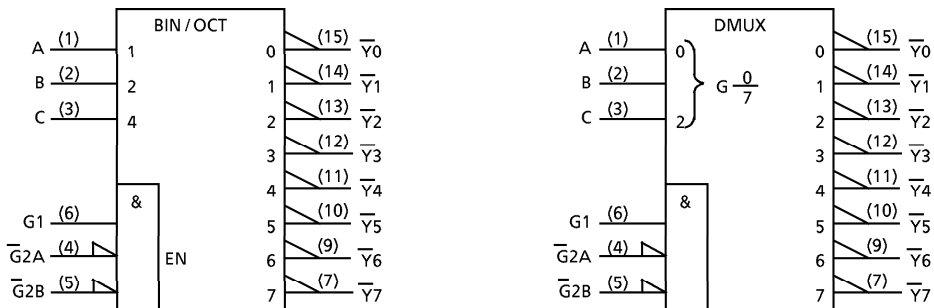

SYSTEM DIAGRAM

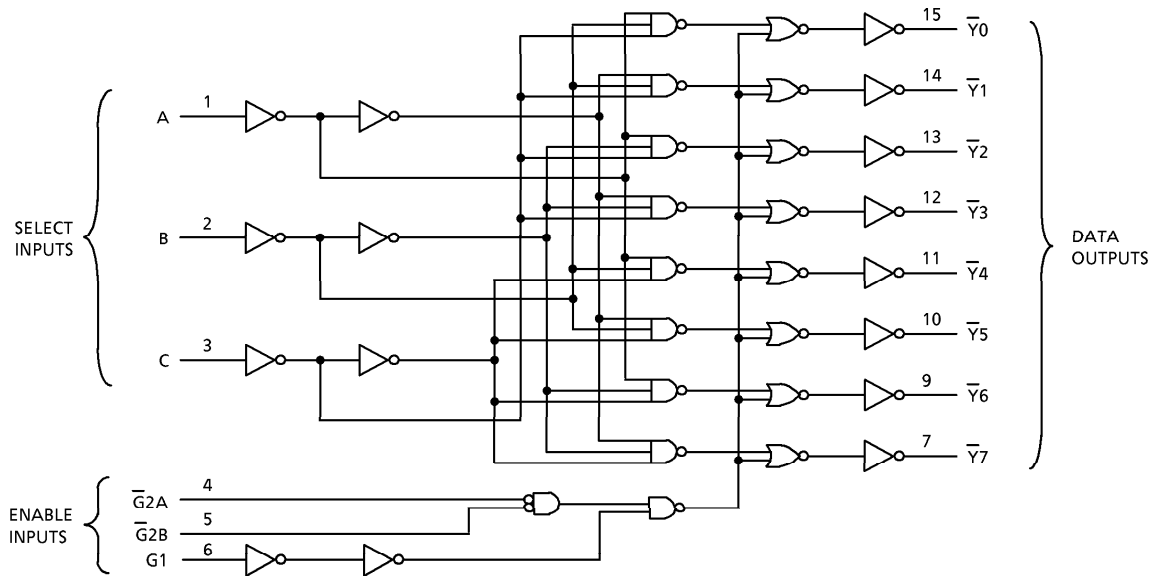

MAXIMUM RATINGS

PARAMETER	SYMBOL	RATING	UNIT
Supply Voltage Range	V_{CC}	-0.5~7.0	V
DC Input Voltage	V_{IN}	-0.5~7.0	V
DC Output Voltage	V_{OUT}	-0.5~ V_{CC} +0.5	V
Input Diode Current	I_{IK}	-20	mA
Output Diode Current	I_{OK}	±20	mA
DC Output Current	I_{OUT}	±25	mA
DC V_{CC} /Ground Current	I_{CC}	±75	mA
Power Dissipation	P_D	180	mW
Storage Temperature	T_{stg}	-65~150	°C

RECOMMENDED OPERATING CONDITIONS

PARAMETER	SYMBOL	RATING	UNIT
Supply Voltage	V_{CC}	2.0~3.6	V
Input Voltage	V_{IN}	0~5.5	V
Output Voltage	V_{OUT}	0~ V_{CC}	V
Operating Temperature	T_{opr}	-40~85	°C
Input Rise And Fall Time	dt/dv	0~100	ns/V

ELECTRICAL CHARACTERISTICS

DC characteristics

PARAMETER		SYM-BOL	TEST CONDITION		V _{CC} (V)	Ta = 25°C			Ta = -40~85°C		UNIT
						MIN.	TYP.	MAX.	MIN.	MAX.	
Input Voltage	"H" Level	V _{IH}			2.0	1.5	—	—	1.5	—	V
					3.0	2.0	—	—	2.0	—	
					3.6	2.4	—	—	2.4	—	
	"L" Level	V _{IL}			2.0	—	—	0.5	—	0.5	
					3.0	—	—	0.8	—	0.8	
					3.6	—	—	0.8	—	0.8	
Output Voltage	"H" Level	V _{OH}	V _{IN} = V _{IH} or V _{IL}	I _{OH} = -50 μA	2.0	1.9	2.0	—	1.9	—	V
				I _{OH} = -50 μA	3.0	2.9	3.0	—	2.9	—	
				I _{OH} = -4mA	3.0	2.58	—	—	2.48	—	
	"L" Level	V _{OL}	V _{IN} = V _{IH} or V _{IL}	I _{OL} = 50 μA	2.0	—	0.0	0.1	—	0.1	
				I _{OL} = 50 μA	3.0	—	0.0	0.1	—	0.1	
				I _{OL} = 4mA	3.0	—	—	0.36	—	0.44	
Input Leakage Current		I _{IN}	V _{IN} = 5.5V or GND		3.6	—	—	±0.1	—	±1.0	μA
Quiescent Supply Current		I _{CC}	V _{IN} = V _{CC} or GND		3.6	—	—	4.0	—	40.0	μA

AC characteristics (Input $t_r = t_f = 3\text{ns}$)

PARAMETER	SYM-BOL	TEST CONDITION	TEST CONDITION		Ta = 25°C			Ta = -40~85°C		UNIT
			V _{CC} (V)	C _L (pF)	MIN.	TYP.	MAX.	MIN.	MAX.	
Propagation Delay Time (A, B, C- \bar{Y})	t _{pLH}		2.7	15	—	7.1	13.8	1.0	16.5	ns
				50	—	9.6	17.3	1.0	20.0	
	3.3 ± 0.3		15	—	5.5	8.8	1.0	10.5		
			50	—	8.0	12.3	1.0	14.0		
Propagation Delay Time (G1- \bar{Y})	t _{pLH}		2.7	15	—	8.7	16.3	1.0	19.5	ns
				50	—	11.2	19.8	1.0	23.0	
	3.3 ± 0.3		15	—	6.8	10.6	1.0	12.5		
			50	—	9.3	14.1	1.0	16.0		
Propagation Delay Time ($\bar{G}2$ - \bar{Y})	t _{pLH}		2.7	15	—	8.8	16.0	1.0	18.5	ns
				50	—	11.3	19.5	1.0	22.0	
	3.3 ± 0.3		15	—	6.9	10.4	1.0	11.5		
			50	—	9.4	13.9	1.0	15.0		
Output To Output Skew	t _{osLH}	(Note 1)	2.7	50	—	—	2.5	—	2.5	ns
	t _{osHL}		3.3 ± 0.3	50	—	—	2.5	—	2.5	
Input Capacitance	C _{IN}	(Note 2)			—	4	10	—	10	pF
Power Dissipation Capacitance	C _{PD}	(Note 3)			—	34	—	—	—	pF

(Note 1) Parameter guaranteed by design.

$$(t_{osLH} = |t_{pLHm} - t_{pLHn}|, t_{osHL} = |t_{pHLm} - t_{pHLn}|)$$

(Note 2) Parameter guaranteed by design.

(Note 3) C_{PD} is defined as the value of the internal equivalent capacitance which is calculated from the operating current consumption.

Average operating current can be obtained by the equation :

$$I_{CC(opr.)} = C_{PD} \cdot V_{CC} \cdot f_{IN} + I_{CC}$$

Noise characteristics (Ta = 25°C, Input $t_r = t_f = 3\text{ns}$, C_L = 50pF)

PARAMETER	SYMBOL	TEST CONDITION	V _{CC} (V)	TYP.	LIMIT	UNIT
Quiet Output Maximum Dynamic	V _{OLP}		3.3	—	0.5	V
Quiet Output Minimum Dynamic	V _{OLV}		3.3	—	-0.5	V
Minimum High Level Dynamic Input Voltage	V _{IHD}		3.3	—	2.0	V
Maximum Low Level Dynamic Input Voltage	V _{ILD}		3.3	—	0.8	V

INPUT EQUIVALENT CIRCUIT

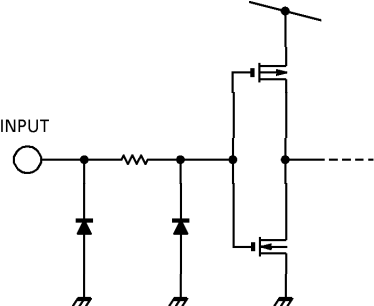

PACKAGE DIMENSIONS
SOP16-P-300-1.27

Unit : mm

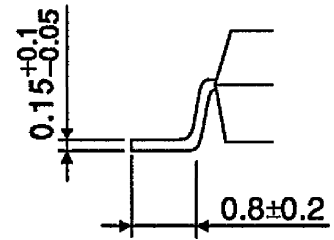
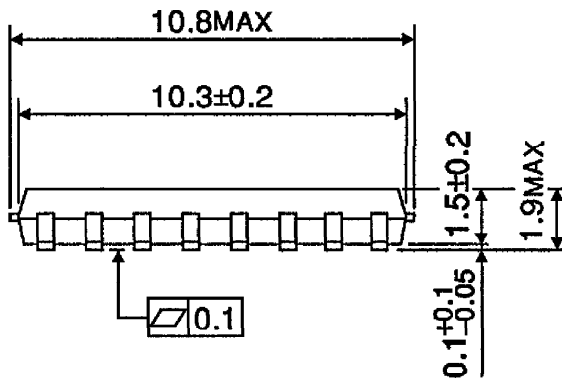
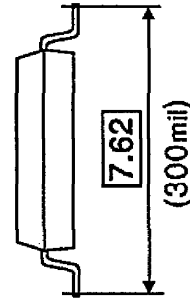
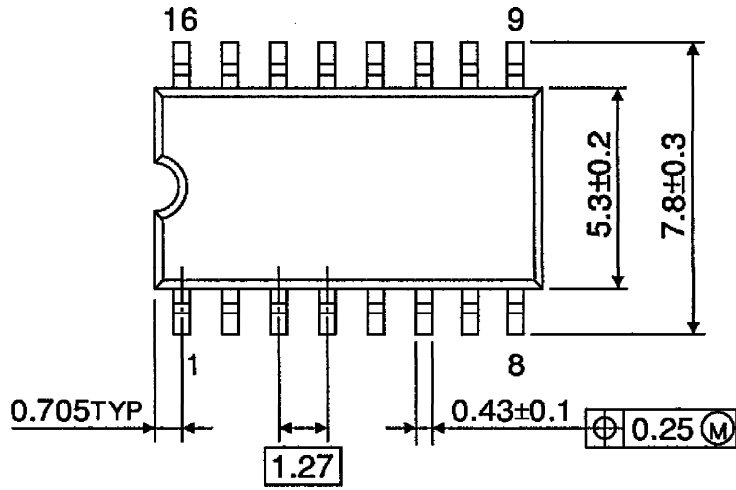

Weight : 0.18g (Typ.)

PACKAGE DIMENSIONS
SOL16-P-150-1.27

Unit : mm

(Note) This package is not available in Japan.

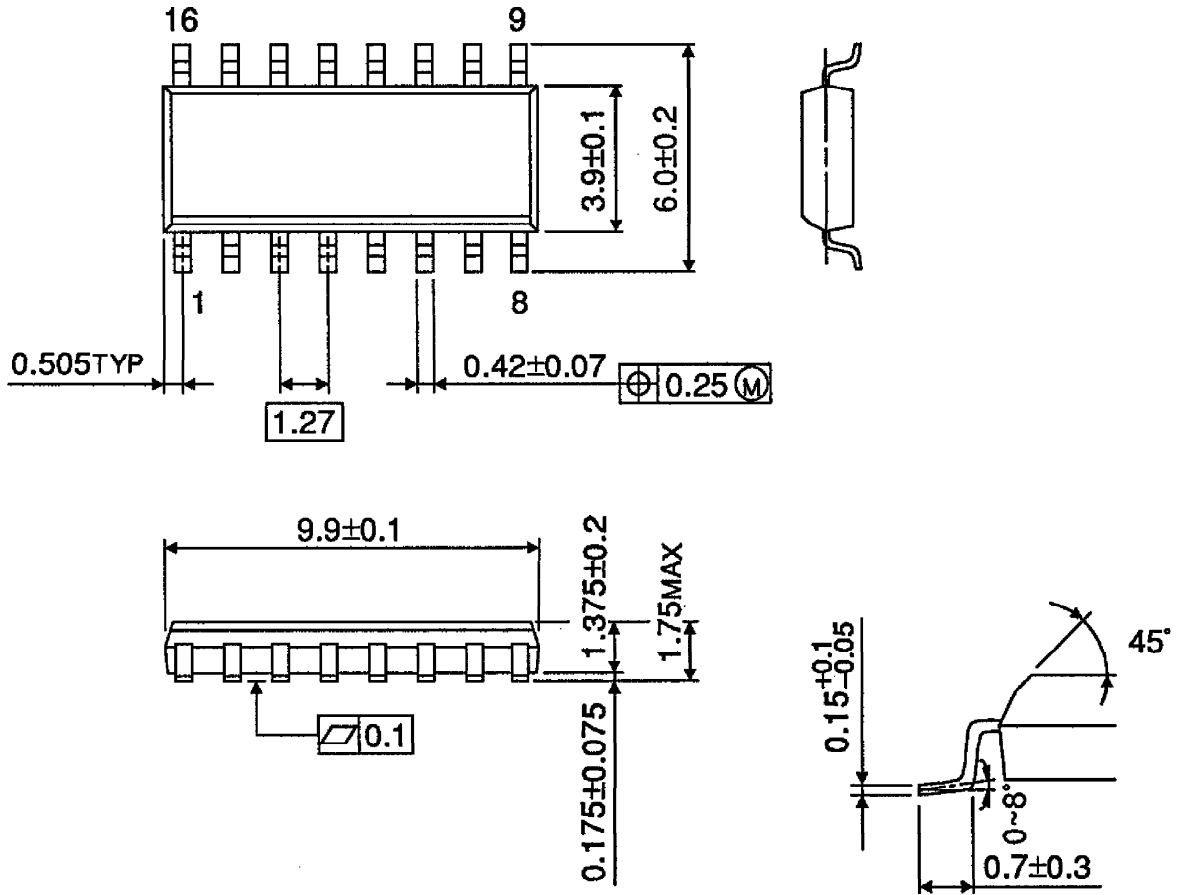

Weight : 0.12g (Typ.)

PACKAGE DIMENSIONS
TSSOP16-P-0044-0.65

Unit : mm

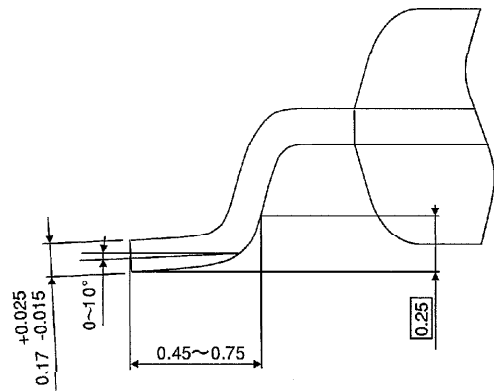
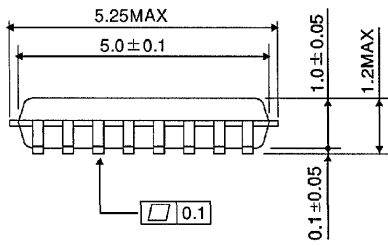
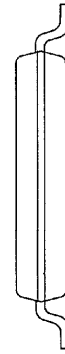
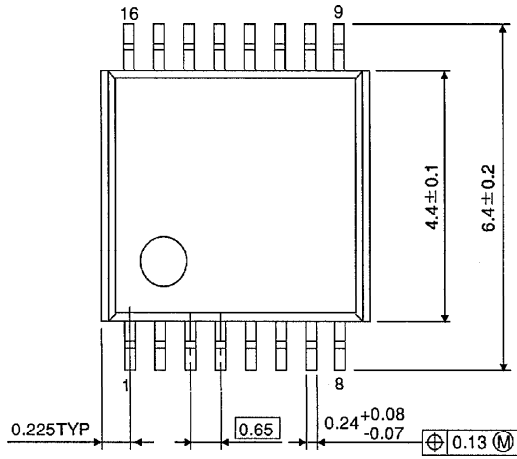

Weight : 0.06g (Typ.)

RESTRICTIONS ON PRODUCT USE

000707EBA

- TOSHIBA is continually working to improve the quality and reliability of its products. Nevertheless, semiconductor devices in general can malfunction or fail due to their inherent electrical sensitivity and vulnerability to physical stress. It is the responsibility of the buyer, when utilizing TOSHIBA products, to comply with the standards of safety in making a safe design for the entire system, and to avoid situations in which a malfunction or failure of such TOSHIBA products could cause loss of human life, bodily injury or damage to property. In developing your designs, please ensure that TOSHIBA products are used within specified operating ranges as set forth in the most recent TOSHIBA products specifications. Also, please keep in mind the precautions and conditions set forth in the "Handling Guide for Semiconductor Devices," or "TOSHIBA Semiconductor Reliability Handbook" etc..
- The TOSHIBA products listed in this document are intended for usage in general electronics applications (computer, personal equipment, office equipment, measuring equipment, industrial robotics, domestic appliances, etc.). These TOSHIBA products are neither intended nor warranted for usage in equipment that requires extraordinarily high quality and/or reliability or a malfunction or failure of which may cause loss of human life or bodily injury ("Unintended Usage"). Unintended Usage include atomic energy control instruments, airplane or spaceship instruments, transportation instruments, traffic signal instruments, combustion control instruments, medical instruments, all types of safety devices, etc.. Unintended Usage of TOSHIBA products listed in this document shall be made at the customer's own risk.
- The products described in this document are subject to the foreign exchange and foreign trade laws.
- The information contained herein is presented only as a guide for the applications of our products. No responsibility is assumed by TOSHIBA CORPORATION for any infringements of intellectual property or other rights of the third parties which may result from its use. No license is granted by implication or otherwise under any intellectual property or other rights of TOSHIBA CORPORATION or others.
- The information contained herein is subject to change without notice.