

SN54HCT652, SN74HCT652 OCTAL BUS TRANSCEIVERS AND REGISTERS WITH 3-STATE OUTPUTS

SCLS179D – MARCH 1984 – REVISED MARCH 2003

- Operating Voltage Range of 4.5 V to 5.5 V
- Low Power Consumption, 80- μ A Max I_{CC}
- Typical $t_{pd} = 12$ ns
- ± 6 -mA Output Drive at 5 V
- Low Input Current of 1 μ A Max
- Inputs Are TTL-Voltage Compatible
- Independent Registers and Enables for A and B Buses
- Multiplexed Real-Time and Stored Data
- True Data Paths
- High-Current 3-State Outputs Can Drive Up To 15 LSTTL Loads

SN54HCT652 . . . JT OR W PACKAGE
SN74HCT652 . . . DW OR NT PACKAGE
(TOP VIEW)

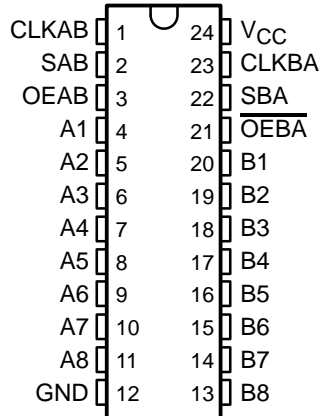

SN54HCT652 . . . FK PACKAGE
(TOP VIEW)

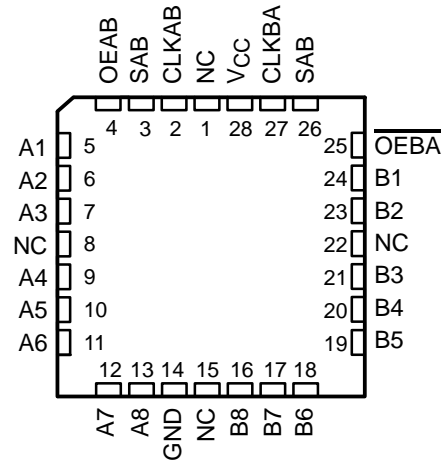

NC – No internal connection

description/ordering information

The 'HCT652 devices consist of bus-transceiver circuits, D-type flip-flops, and control circuitry arranged for multiplexed transmission of data directly from the data bus or from the internal storage registers. Output-enable (OEAB and \overline{OEBA}) inputs are provided to control the transceiver functions. Select-control (SAB and SBA) inputs are provided to select real-time or stored data transfer. A low input level selects real-time data; a high input level selects stored data. Figure 1 illustrates the four fundamental bus-management functions that can be performed with these devices.

ORDERING INFORMATION

T_A	PACKAGE†		ORDERABLE PART NUMBER	TOP-SIDE MARKING
-40°C to 85°C	PDIP – NT	Tube	SN74HCT652NT	HCT652
	SOIC – DW	Tube	SN74HCT652DW	
		Tape and reel	SN74HCT652DWR	
-55°C to 125°C	CDIP – JT	Tube	SNJ54HCT652JT	SNJ54HCT652JT
	CFP – W	Tube	SNJ54HCT652W	SNJ54HCT652W
	LCCC – FK	Tube	SNJ54HCT652FK	SNJ54HCT652FK

† Package drawings, standard packing quantities, thermal data, symbolization, and PCB design guidelines are available at www.ti.com/sc/package.



Please be aware that an important notice concerning availability, standard warranty, and use in critical applications of Texas Instruments semiconductor products and disclaimers thereto appears at the end of this data sheet.

UNLESS OTHERWISE NOTED this document contains PRODUCTION DATA information current as of publication date. Products conform to specifications per the terms of Texas Instruments standard warranty. Production processing does not necessarily include testing of all parameters.

 **TEXAS
INSTRUMENTS**

POST OFFICE BOX 655303 • DALLAS, TEXAS 75265

Copyright © 2003, Texas Instruments Incorporated

SN54HCT652, SN74HCT652 OCTAL BUS TRANSCEIVERS AND REGISTERS WITH 3-STATE OUTPUTS

SCLS179D – MARCH 1984 – REVISED MARCH 2003

description/ordering information (continued)

Data on the A or B data bus, or both, can be stored in the internal D-type flip-flops by low-to-high transitions at the appropriate clock (CLKAB or CLKBA) terminals, regardless of the select- or output-control terminals. When SAB and SBA are in the real-time transfer mode, it is possible to store data without using the internal D-type flip-flops by simultaneously enabling OEAB and \overline{OEBA} . In this configuration, each output reinforces its input. When all other data sources to the two sets of bus lines are at high impedance, each set of bus lines remains at its last state.

To ensure the high-impedance state during power up or power down, \overline{OEBA} should be tied to V_{CC} through a pullup resistor and OEAB should be tied to GND through a pulldown resistor; the minimum value of the resistor is determined by the current-sinking/current-sourcing capability of the driver.

FUNCTION TABLE

INPUTS						DATA I/O†		OPERATION OR FUNCTION
OEAB	\overline{OEBA}	CLKAB	CLKBA	SAB	SBA	A1–A8	B1–B8	
L	H	H or L	H or L	X	X	Input	Input	Isolation
L	H	↑	↑	X	X	Input	Input	Store A and B data
X	H	↑	H or L	X	X	Input	Unspecified‡	Store A, hold B
H	H	↑	↑	X‡	X	Input	Output	Store A in both registers
L	X	H or L	↑	X	X	Unspecified‡	Input	Hold A, store B
L	L	↑	↑	X	X‡	Output	Input	Store B in both registers
L	L	X	X	X	L	Output	Input	Real-time B data to A bus
L	L	X	H or L	X	H	Output	Input	Stored B data to A bus
H	H	X	X	L	X	Input	Output	Real-time A data to B bus
H	H	H or L	X	H	X	Input	Output	Stored A data to B bus
H	L	H or L	H or L	H	H	Output	Output	Stored A data to B bus and stored B data to A bus

† The data-output functions can be enabled or disabled by a variety of level combinations at OEAB or \overline{OEBA} . Data-input functions always are enabled; i.e., data at the bus terminals is stored on every low-to-high transition on the clock inputs.

‡ Select control = L: clocks can occur simultaneously.

Select control = H: clocks must be staggered to load both registers.



SN54HCT652, SN74HCT652 OCTAL BUS TRANSCEIVERS AND REGISTERS WITH 3-STATE OUTPUTS

SCLS179D – MARCH 1984 – REVISED MARCH 2003

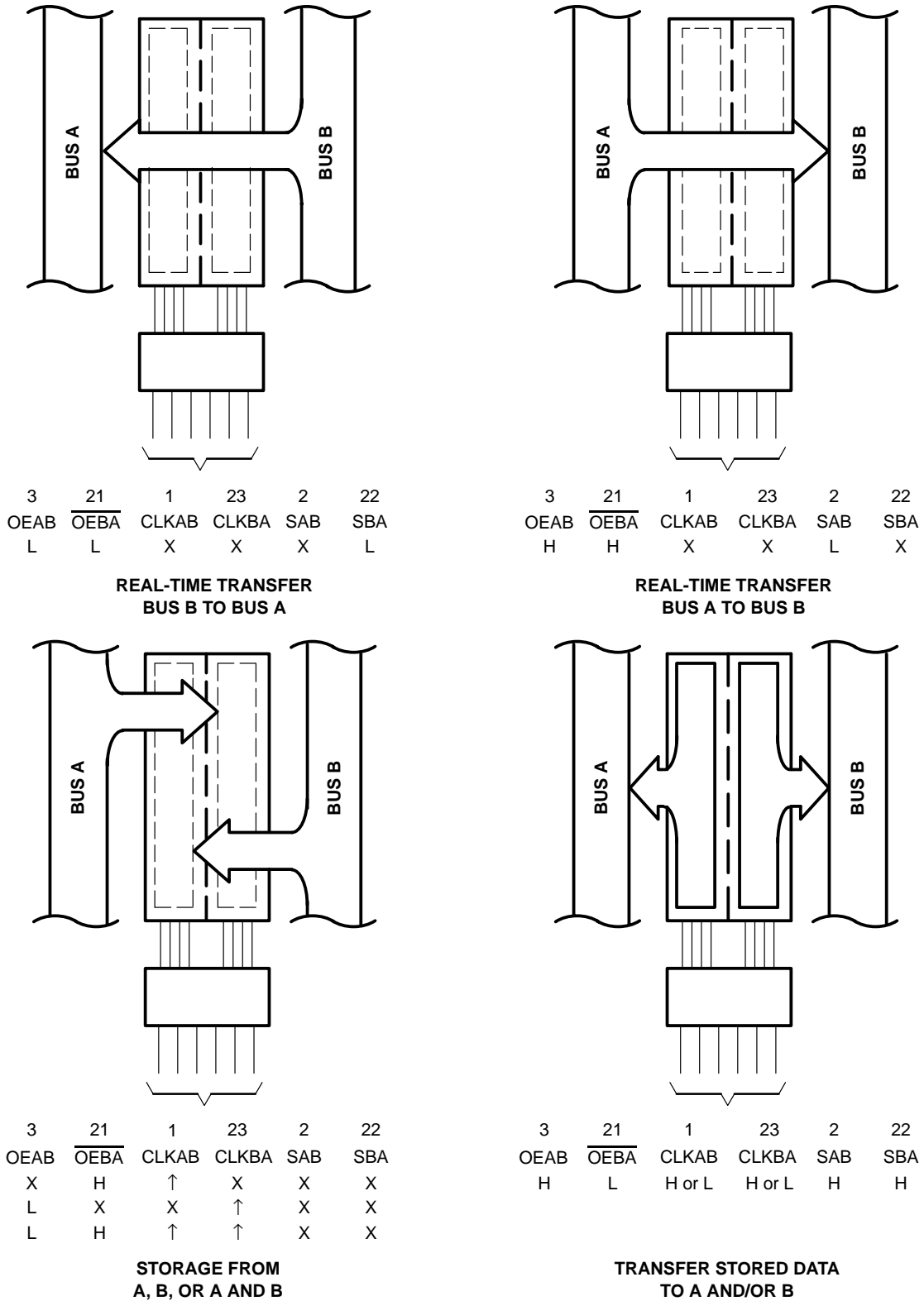

Pin numbers shown are for the DW, JT, NT, and W packages.

Figure 1. Bus-Management Functions

SN54HCT652, SN74HCT652 OCTAL BUS TRANSCEIVERS AND REGISTERS WITH 3-STATE OUTPUTS

SCLS179D – MARCH 1984 – REVISED MARCH 2003

logic diagram (positive logic)

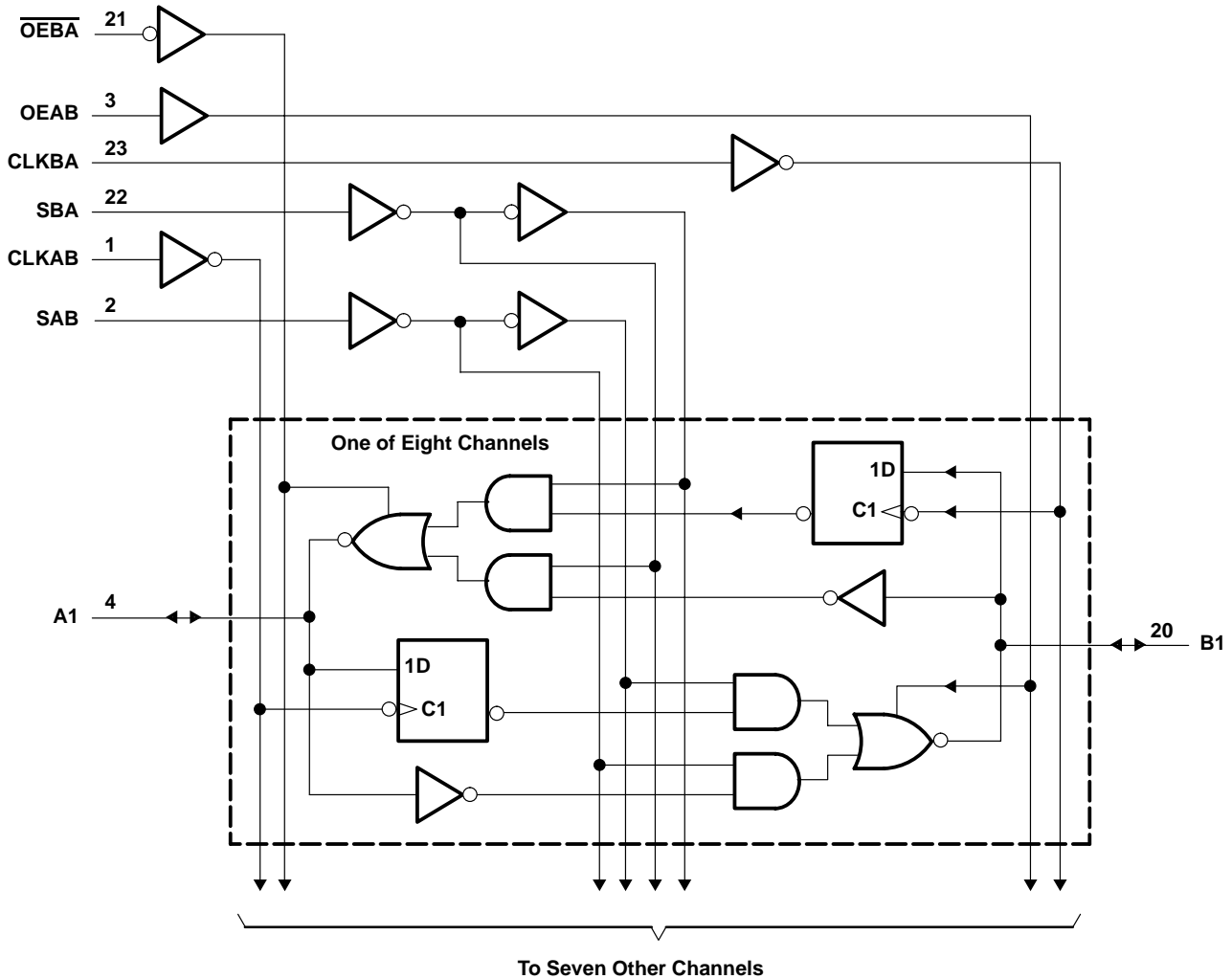

Pin numbers shown are for the DW, JT, NT, and W packages.

absolute maximum ratings over operating free-air temperature range (unless otherwise noted)†

Supply voltage range, V_{CC}	-0.5 V to 7 V
Input clamp current, I_{IK} ($V_I < 0$ or $V_I > V_{CC}$) (see Note 1)	± 20 mA
Output clamp current, I_{OK} ($V_O < 0$ or $V_O > V_{CC}$) (see Note 1)	± 20 mA
Continuous output current, I_O ($V_O = 0$ to V_{CC})	± 35 mA
Continuous current through V_{CC} or GND	± 70 mA
Package thermal impedance, θ_{JA} (see Note 2): DW package	46°C/W
(see Note 3): NT package	67°C/W
Storage temperature range, T_{stg}	-65°C to 150°C

† Stresses beyond those listed under "absolute maximum ratings" may cause permanent damage to the device. These are stress ratings only, and functional operation of the device at these or any other conditions beyond those indicated under "recommended operating conditions" is not implied. Exposure to absolute-maximum-rated conditions for extended periods may affect device reliability.

- NOTES: 1. The input and output voltage ratings may be exceeded if the input and output current ratings are observed.
 2. The package thermal impedance is calculated in accordance with JESD 51-7.
 3. The package thermal impedance is calculated in accordance with JESD 51-3.



POST OFFICE BOX 655303 • DALLAS, TEXAS 75265

SN54HCT652, SN74HCT652 OCTAL BUS TRANSCEIVERS AND REGISTERS WITH 3-STATE OUTPUTS

SCLS179D – MARCH 1984 – REVISED MARCH 2003

recommended operating conditions (see Note 4)

		SN54HCT652			SN74HCT652			UNIT
		MIN	NOM	MAX	MIN	NOM	MAX	
V _{CC}	Supply voltage	4.5	5	5.5	4.5	5	5.5	V
V _{IH}	High-level input voltage	V _{CC} = 4.5 V to 5.5 V			2			V
V _{IL}	Low-level input voltage	V _{CC} = 4.5 V to 5.5 V			0.8			V
V _I	Input voltage	0			V _{CC}			V
V _O	Output voltage	0			V _{CC}			V
t _t	Input transition (rise and fall) time	500			500			ns
T _A	Operating free-air temperature	-55			125			°C

NOTE 4: All unused inputs of the device must be held at V_{CC} or GND to ensure proper device operation. Refer to the TI application report, *Implications of Slow or Floating CMOS Inputs*, literature number SCBA004.

electrical characteristics over recommended operating free-air temperature range (unless otherwise noted)

PARAMETER	TEST CONDITIONS	V _{CC}	T _A = 25°C		SN54HCT652		SN74HCT652		UNIT
			MIN	TYP	MAX	MIN	MAX	MIN	
V _{OH}	V _I = V _{IH} or V _{IL}	4.5 V	I _{OH} = -20 μA		4.4		4.4		V
			I _{OH} = -6 mA		3.98		3.7		
V _{OL}	V _I = V _{IH} or V _{IL}	4.5 V	I _{OL} = 20 μA		0.001		0.1		V
			I _{OL} = 6 mA		0.17		0.26		
I _I	Control inputs	V _I = V _{CC} or 0	5.5 V		±0.1	±100	±1000	±1000	nA
I _{OZ}	A or B	V _O = V _{CC} or 0, V _I = V _{IH} or V _{IL} , Data = V _{CC} or 0	5.5 V		±0.01	±0.5	±10	±5	μA
I _{CC}		V _I = V _{CC} or 0, I _O = 0	5.5 V		8		160		μA
ΔI _{CC} †		One input at 0.5 V or 2.4 V, Other inputs at 0 or V _{CC}	5.5 V		1.4		2.4		mA
C _i	Control inputs	4.5 V to 5.5 V	5.5 V		3		10		pF

† This is the increase in supply current for each input that is at one of the specified TTL voltage levels, rather than 0 V or V_{CC}.

timing requirements over recommended operating free-air temperature range (unless otherwise noted)

		V _{CC}	T _A = 25°C		SN54HCT652		SN74HCT652		UNIT
			MIN	MAX	MIN	MAX	MIN	MAX	
f _{clock}	Clock frequency	4.5 V	25		17		20		MHz
		5.5 V	28		19		22		
t _w	Pulse duration, CLKBA or CLKAB high or low	4.5 V	20		30		25		ns
		5.5 V	18		27		23		
t _{su}	Setup time, A before CLKAB↑ or B before CLKBA↑	4.5 V	15		23		19		ns
		5.5 V	14		21		17		
t _h	Hold time, A after CLKAB↑ or B after CLKBA↑	4.5 V	5		5		5		ns
		5.5 V	5		5		5		

PRODUCT PREVIEW information concerns products in the formative or design phase of development. Characteristic data and other specifications are design goals. Texas Instruments reserves the right to change or discontinue these products without notice.



POST OFFICE BOX 655303 • DALLAS, TEXAS 75265

SN54HCT652, SN74HCT652 OCTAL BUS TRANSCEIVERS AND REGISTERS WITH 3-STATE OUTPUTS

SCLS179D – MARCH 1984 – REVISED MARCH 2003

switching characteristics over recommended operating free-air temperature range, $C_L = 50 \text{ pF}$ (unless otherwise noted) (see Figure 2)

PARAMETER	FROM (INPUT)	TO (OUTPUT)	V _{CC}	T _A = 25°C			SN54HCT652		SN74HCT652		UNIT
				MIN	TYP	MAX	MIN	MAX	MIN	MAX	
f _{max}			4.5 V	25	35		17		20	MHz	
			5.5 V	28	40		19		22		
t _{pd}	CLKBA or CLKAB	A or B	4.5 V		18	36		54		45	ns
			5.5 V		16	32		49		41	
	A or B	B or A	4.5 V		14	27		41		34	
			5.5 V		12	24		37		31	
	SBA or SAB†	A or B	4.5 V		20	38		57		48	
			5.5 V		17	34		51		43	
t _{en}	$\overline{\text{OEBA}}$ or OEAB	A or B	4.5 V		25	49		74		61	ns
			5.5 V		22	44		67		55	
t _{dis}	$\overline{\text{OEBA}}$ or OEAB	A or B	4.5 V		25	49		74		61	ns
			5.5 V		22	44		67		55	
t _t		Any	4.5 V		9	12		18		15	ns
			5.5 V		7	11		16		14	

† These parameters are measured with the internal output state of the storage register opposite that of the bus input.

switching characteristics over recommended operating free-air temperature range, $C_L = 150 \text{ pF}$ (unless otherwise noted) (see Figure 2)

PARAMETER	FROM (INPUT)	TO (OUTPUT)	V _{CC}	T _A = 25°C			SN54HCT652		SN74HCT652		UNIT
				MIN	TYP	MAX	MIN	MAX	MIN	MAX	
t _{pd}	CLKBA or CLKAB	A or B	4.5 V		24	53		80		66	ns
			5.5 V		22	47		72		60	
	A or B	B or A	4.5 V		22	44		70		55	
			5.5 V		20	39		60		50	
	SBA or SAB†	A or B	4.5 V		26	55		83		69	
			5.5 V		24	49		74		62	
t _{en}	$\overline{\text{OEBA}}$ or OEAB	A or B	4.5 V		33	66		100		82	ns
			5.5 V		30	59		90		74	
t _t		Any	4.5 V		17	42		63		53	ns
			5.5 V		14	38		57		48	

† These parameters are measured with the internal output state of the storage register opposite that of the bus input.

operating characteristics, T_A = 25°C

PARAMETER	TEST CONDITIONS	TYP	UNIT
C _{pd} Power dissipation capacitance	No load	50	pF

PRODUCT PREVIEW information concerns products in the formative or design phase of development. Characteristic data and other specifications are design goals. Texas Instruments reserves the right to change or discontinue these products without notice.



SN54HCT652, SN74HCT652 OCTAL BUS TRANSCEIVERS AND REGISTERS WITH 3-STATE OUTPUTS

SCLS179D – MARCH 1984 – REVISED MARCH 2003

PARAMETER MEASUREMENT INFORMATION

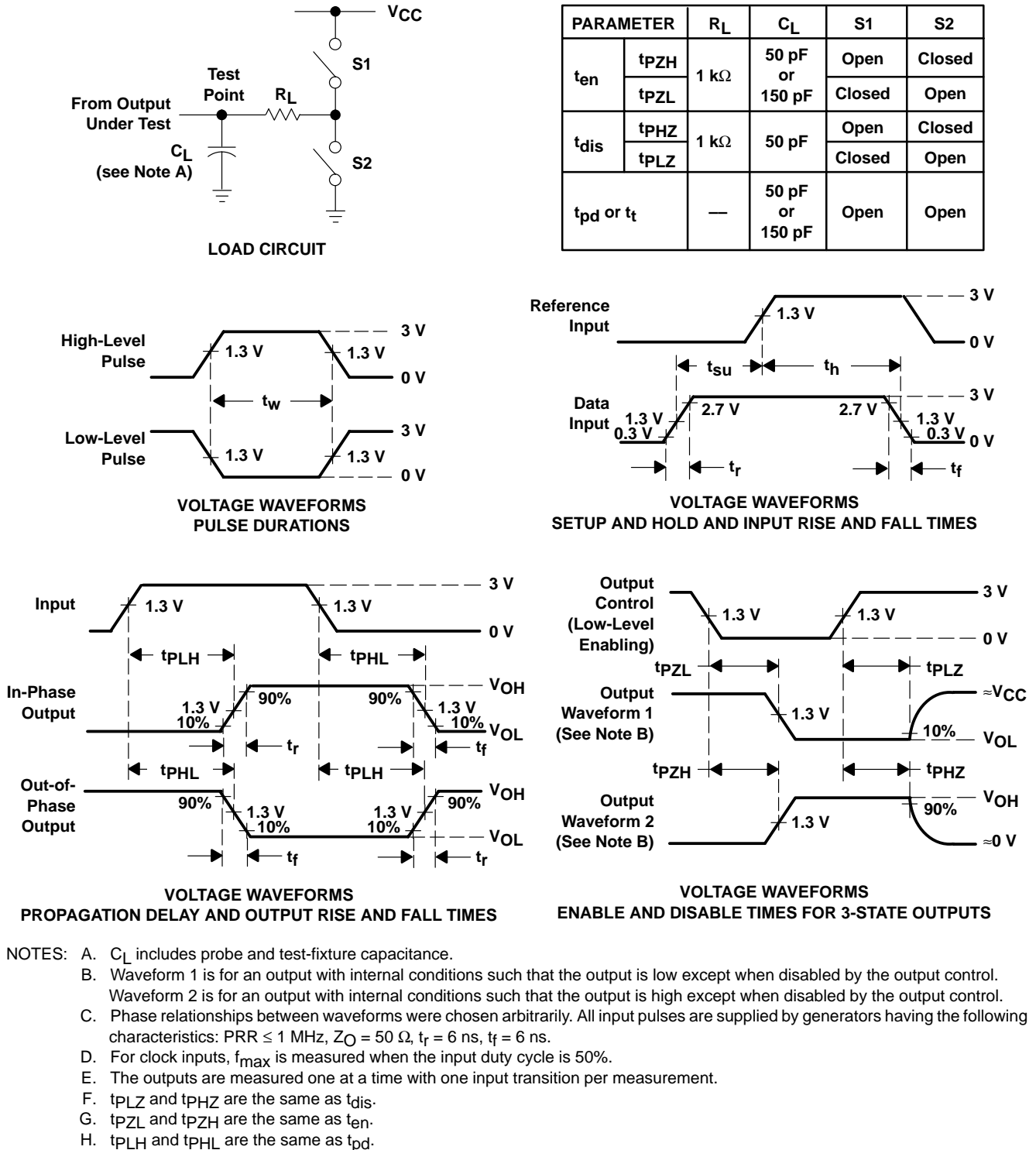

Figure 1. Load Circuit and Voltage Waveforms

NT (R-PDIP-T**)

PLASTIC DUAL-IN-LINE PACKAGE

24 PINS SHOWN



NOTES: A. All linear dimensions are in inches (millimeters).
 B. This drawing is subject to change without notice.

DW (R-PDSO-G**)

PLASTIC SMALL-OUTLINE PACKAGE

16 PINS SHOWN

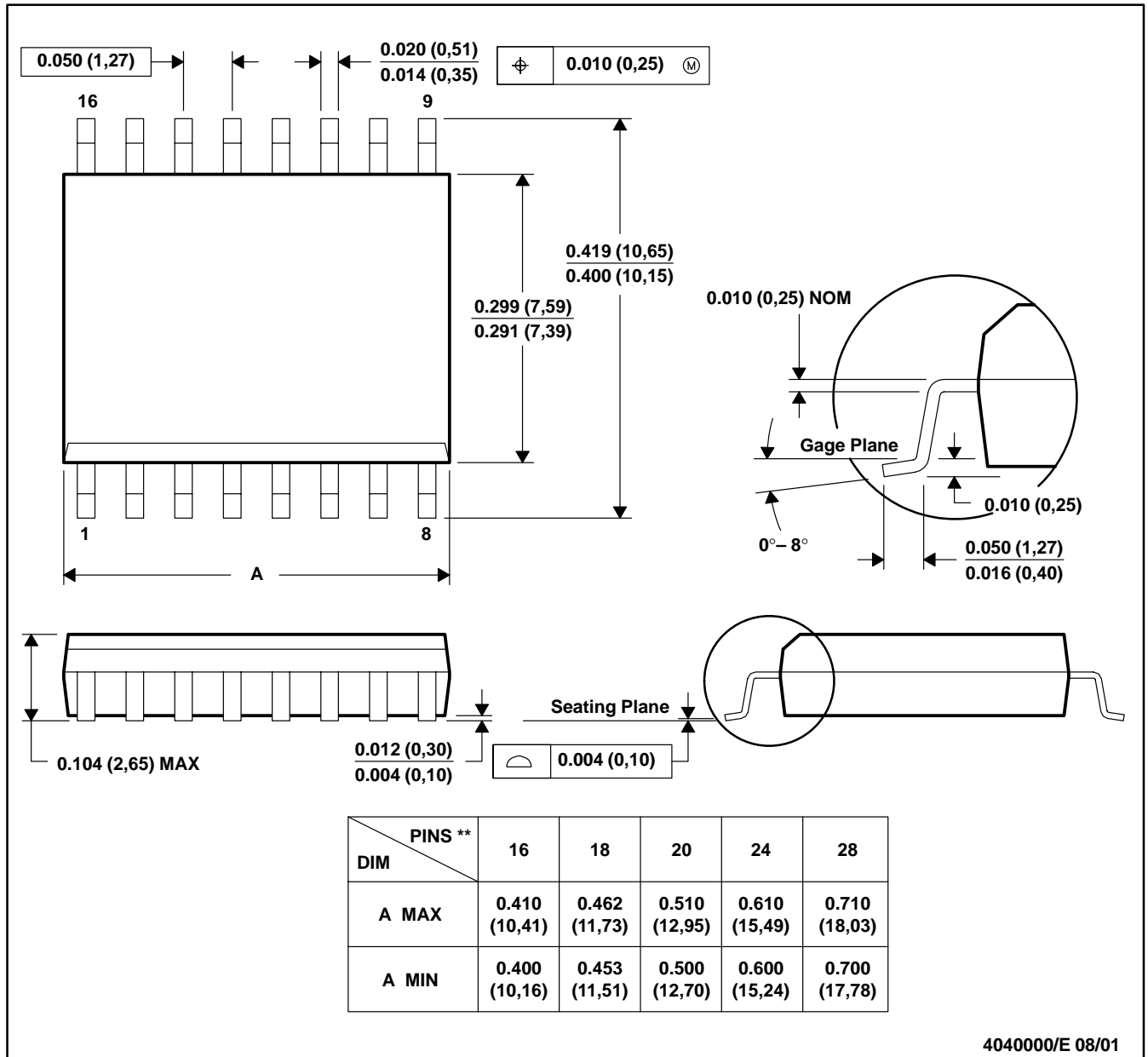

4040000/E 08/01

- NOTES: A. All linear dimensions are in inches (millimeters).
 B. This drawing is subject to change without notice.
 C. Body dimensions do not include mold flash or protrusion not to exceed 0.006 (0,15).
 D. Falls within JEDEC MS-013

IMPORTANT NOTICE

Texas Instruments Incorporated and its subsidiaries (TI) reserve the right to make corrections, modifications, enhancements, improvements, and other changes to its products and services at any time and to discontinue any product or service without notice. Customers should obtain the latest relevant information before placing orders and should verify that such information is current and complete. All products are sold subject to TI's terms and conditions of sale supplied at the time of order acknowledgment.

TI warrants performance of its hardware products to the specifications applicable at the time of sale in accordance with TI's standard warranty. Testing and other quality control techniques are used to the extent TI deems necessary to support this warranty. Except where mandated by government requirements, testing of all parameters of each product is not necessarily performed.

TI assumes no liability for applications assistance or customer product design. Customers are responsible for their products and applications using TI components. To minimize the risks associated with customer products and applications, customers should provide adequate design and operating safeguards.

TI does not warrant or represent that any license, either express or implied, is granted under any TI patent right, copyright, mask work right, or other TI intellectual property right relating to any combination, machine, or process in which TI products or services are used. Information published by TI regarding third-party products or services does not constitute a license from TI to use such products or services or a warranty or endorsement thereof. Use of such information may require a license from a third party under the patents or other intellectual property of the third party, or a license from TI under the patents or other intellectual property of TI.

Reproduction of information in TI data books or data sheets is permissible only if reproduction is without alteration and is accompanied by all associated warranties, conditions, limitations, and notices. Reproduction of this information with alteration is an unfair and deceptive business practice. TI is not responsible or liable for such altered documentation.

Resale of TI products or services with statements different from or beyond the parameters stated by TI for that product or service voids all express and any implied warranties for the associated TI product or service and is an unfair and deceptive business practice. TI is not responsible or liable for any such statements.

Mailing Address:

Texas Instruments
Post Office Box 655303
Dallas, Texas 75265