

T-03-19

SCHOTTKY-BARRIER DOUBLE RECTIFIER DIODES

Low-leakage platinum-barrier double rectifier diodes in plastic envelopes, featuring low forward voltage drop, low capacitance, and absence of stored charge. They are intended for use in switched-mode power supplies and high-frequency circuits in general, where both low conduction losses and zero switching losses are important. Their single chip (monolithic) construction allows both diodes to be paralleled without the need for derating. They can also withstand reverse voltage transients and have guaranteed reverse avalanche surge capability. The series consists of common-cathode types.

QUICK REFERENCE DATA

Per diode, unless otherwise stated			PBYR2535CT	2540CT	2545CT	
Repetitive peak reverse voltage	V_{RRM}	max.	35	40	45	V
Output current (both diodes conducting)	I_O	max.	30			A
Forward voltage	V_F	<	0.73			V
Junction temperature	T_j	max.	150			°C

MECHANICAL DATA

Fig.1 TO-220AB.

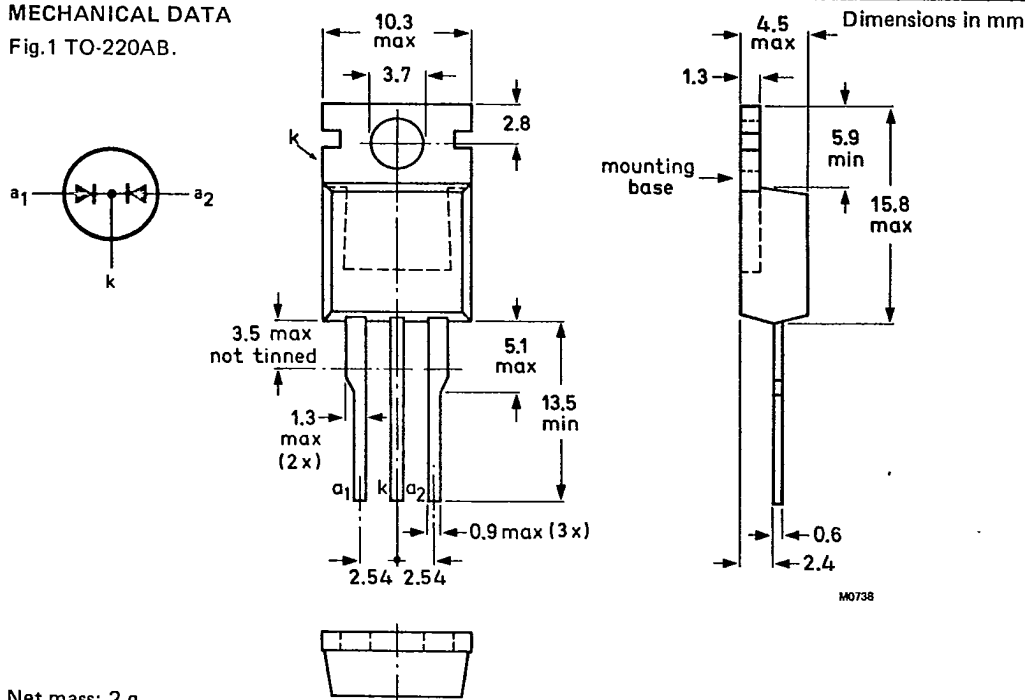

Net mass: 2 g.

Note: the exposed metal mounting base is directly connected to the common cathode.
 Accessories supplied on request: see data sheets Mounting instructions and accessories for TO-220 envelopes.

RATINGS

Limiting values in accordance with the Absolute Maximum System (IEC 134).

T-03-19

Voltages (per diode)

			PBYR2535CT	2540CT	2545CT	
Repetitive peak reverse voltage	V_{RRM}	max.	35	40	45	V
Crest working reverse voltage	V_{RWM}	max.	35	40	45	V
Continuous reverse voltage	V_R	max.	35	40	45	V

Currents

Average forward current

square wave; $\delta = 0.5$;
 up to $T_h = 130^\circ\text{C}$ (note 1)
 per diode
 per device

$I_{F(AV)}$	max.	15	A
I_O	max.	30	A

Repetitive peak forward current

per diode (note 1)
 $t_p = 25 \mu\text{s}$; $\delta = 0.5$, $T_h = 130^\circ\text{C}$

I_{FRM}	max.	30	A
-----------	------	----	---

Non-repetitive peak forward current

(per device) half sinewave; $T_j = 125^\circ\text{C}$
 prior to surge with reapplied V_{RWM} max
 $t = 10 \text{ ms}$
 $t = 8.3 \text{ ms}$

I_{FSM}	max.	135	A
I_{FSM}	max.	150	A

I^2t for fusing ($t = 10 \text{ ms}$; per device)

I^2t	max.	93	A^2s
--------	------	----	----------------------

Reverse surge current (per diode)

$t_p = 2 \mu\text{s}$; $\delta = 0.001$
 $t_p = 100 \mu\text{s}$

I_{RRM}	max.	1.0	A
I_{RSM}	max.	1.0	A

Temperatures

Storage temperature

T_{stg}		-65 to +175	$^\circ\text{C}$
-----------	--	-------------	------------------

Junction temperature

T_j	max.	150	$^\circ\text{C}$
-------	------	-----	------------------

CHARACTERISTICS (per diode)

Forward voltage (note 2)

$I_F = 30 \text{ A}$; $T_j = 125^\circ\text{C}$
 $I_F = 30 \text{ A}$; $T_j = 25^\circ\text{C}$

V_F	<	0.73	V
V_F	<	0.82	V

Reverse current

$V_R = V_{RWM}$ max; $T_j = 125^\circ\text{C}$
 $V_R = V_{RWM}$ max; $T_j = 25^\circ\text{C}$

I_R	<	40	mA
I_R	<	0.2	mA

Notes:

1. At rated reverse voltage V_R .
2. Measured under pulse conditions to avoid excessive dissipation.

N AMER PHILIPS/DISCRETE 2SE D 665393J 0022979 9

THERMAL RESISTANCE

From junction to mounting base (both diodes conducting)	$R_{th\ j-mb}$	=	1.0	K/W
From junction to mounting base (per diode)	$R_{th\ j-mb}$	=	1.5	K/W

Influence of mounting method

1. Heatsink-mounted with clip (see mounting instructions)

T-03-19

Thermal resistance from mounting base to heatsink

a. with heatsink compound	$R_{th\ mb-h}$	=	0.5	K/W
b. with heatsink compound and 0.06 mm maximum mica insulator	$R_{th\ mb-h}$	=	1.4	K/W
c. with heatsink compound and 0.1 mm maximum mica insulator (56369)	$R_{th\ mb-h}$	=	2.2	K/W
d. with heatsink compound and 0.25 mm maximum alumina insulator (56367)	$R_{th\ mb-h}$	=	0.8	K/W
e. without heatsink compound	$R_{th\ mb-h}$	=	1.4	K/W

2. Free air operation

The quoted value of $R_{th\ j-a}$ should be used only when no leads of other dissipating components run to the same tie point.

Thermal resistance from junction to ambient in free air:
mounted on a printed circuit board at any device lead
length and with copper laminate on the board

$R_{th\ j-a}$	=	60	K/W
---------------	---	----	-----

MOUNTING INSTRUCTIONS

- The device may be soldered directly into the circuit, but the maximum permissible temperature of the soldering iron or bath is 275 °C; the heat source must not be in contact with the joint for more than 5 seconds. Soldered joints must be at least 4.7 mm from the seal.
- The leads should not be bent less than 2.4 mm from the seal, and should be supported during bending. The bend radius must be no less than 1.0 mm.
- Mounting by means of a spring clip is the best mounting method because it offers:
 - a good thermal contact under the crystal area and slightly lower $R_{th\ mb-h}$ values than does screw mounting.
 - safe isolation for mains operation.
However, if a screw is used, it should be M3 cross-recess pan head. Care should be taken to avoid damage to the plastic body.
- For good thermal contact heatsink compound should be used between mounting base and heatsink. Values of $R_{th\ mb-h}$ given for mounting with heatsink compound refer to the use of a metallic-oxide loaded compound. Ordinary silicone grease is not recommended.
- Rivet mounting (only possible for non-insulated mounting).
Devices may be rivetted to flat heatsinks; such a process must neither deform the mounting tab, nor enlarge the mounting hole.

SQUARE-WAVE OPERATION

T-03-19

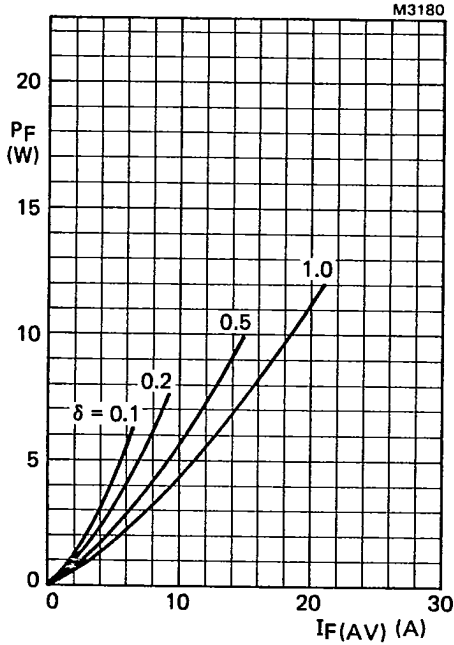
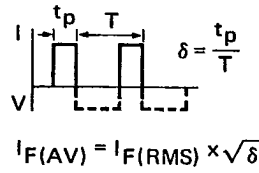

Fig.2 Forward current power rating; per diode.



SINUSOIDAL OPERATION

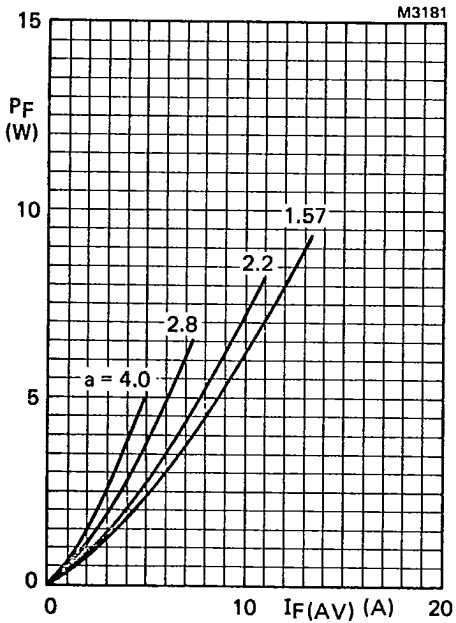

Fig.3 Forward current power rating; per diode.

a = form factor = $I_{F(RMS)} / I_{F(AV)}$

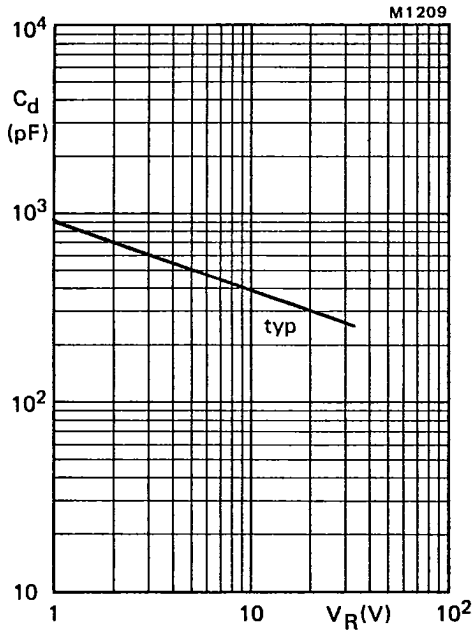

Fig.4 Typical junction capacitance at $f = 1$ MHz; per diode; $T_j = 25$ to 125 °C.

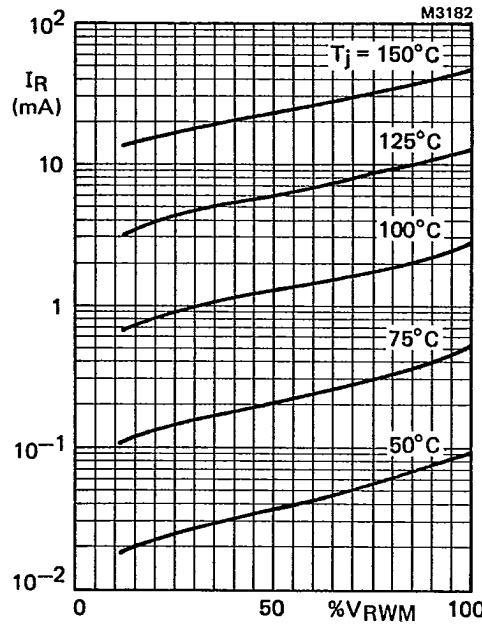

Fig.5 Typical values; per diode.

T-03-19

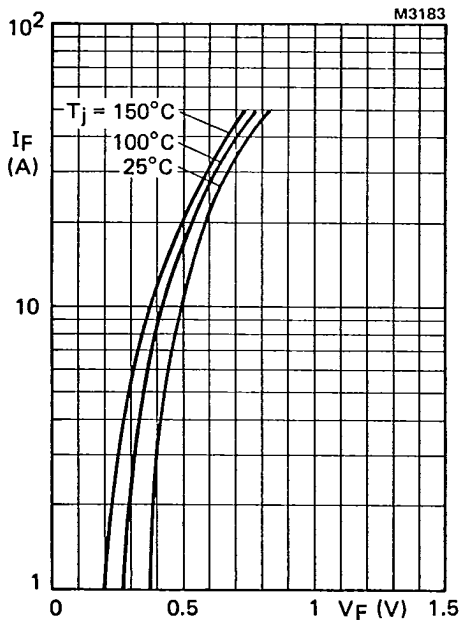

Fig.6 Typical forward voltage; per diode.