

# BCD-To-Seven Segment Latch/Decoder/Driver

The MC14511B BCD-to-seven segment latch/decoder/driver is constructed with complementary MOS (CMOS) enhancement mode devices and NPN bipolar output drivers in a single monolithic structure. The circuit provides the functions of a 4-bit storage latch, an 8421 BCD-to-seven segment decoder, and an output drive capability. Lamp test ( $\overline{LT}$ ), blanking ( $\overline{BI}$ ), and latch enable (LE) inputs are used to test the display, to turn-off or pulse modulate the brightness of the display, and to store a BCD code, respectively. It can be used with seven-segment light-emitting diodes (LED), incandescent, fluorescent, gas discharge, or liquid crystal readouts either directly or indirectly.

Applications include instrument (e.g., counter, DVM, etc.) display driver, computer/calculator display driver, cockpit display driver, and various clock, watch, and timer uses.

- Low Logic Circuit Power Dissipation
- High-Current Sourcing Outputs (Up to 25 mA)
- Latch Storage of Code
- Blanking Input
- Lamp Test Provision
- Readout Blanking on all Illegal Input Combinations
- Lamp Intensity Modulation Capability
- Time Share (Multiplexing) Facility
- Supply Voltage Range = 3.0 V to 18 V
- Capable of Driving Two Low-power TTL Loads, One Low-power Schottky TTL Load or Two HTL Loads Over the Rated Temperature Range
- Chip Complexity: 216 FETs or 54 Equivalent Gates
- Triple Diode Protection on all Inputs

### MAXIMUM RATINGS\* (Voltages Referenced to $V_{SS}$ )

Rating	Symbol	Value	Unit
DC Supply Voltage	$V_{DD}$	- 0.5 to + 18	V
Input Voltage, All Inputs	$V_{in}$	- 0.5 to $V_{DD} + 0.5$	V
DC Current Drain per Input Pin	I	10	mA
Operating Temperature Range	$T_A$	- 55 to + 125	°C
Power Dissipation per Package†	$P_D$	500	mW
Storage Temperature Range	$T_{stg}$	- 65 to + 150	°C
Maximum Output Drive Current (Source) per Output	$I_{OHmax}$	25	mA
Maximum Continuous Output Power (Source) per Output ‡	$P_{OHmax}$	50	mW

‡ $P_{OHmax} = I_{OH} (V_{DD} - V_{OH})$

\* Maximum Ratings are those values beyond which damage to the device may occur.

† Temperature Derating:

Plastic "P and D/DW" Packages: - 7.0 mW/°C From 65°C To 125°C

Ceramic "L" Packages: - 12 mW/°C From 100°C To 125°C

## MC14511B

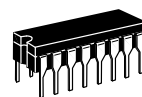

**L SUFFIX**  
CERAMIC  
CASE 620

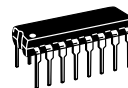

**P SUFFIX**  
PLASTIC  
CASE 648



**D SUFFIX**  
SOIC  
CASE 751B



**DW SUFFIX**  
SOIC  
CASE 751G

### ORDERING INFORMATION

MC14XXXBCP	Plastic
MC14XXXBCL	Ceramic
MC14XXXBDW	SOIC
MC14XXXBD	SOIC

$T_A = -55^\circ$  to  $125^\circ\text{C}$  for all packages.

### PIN ASSIGNMENT

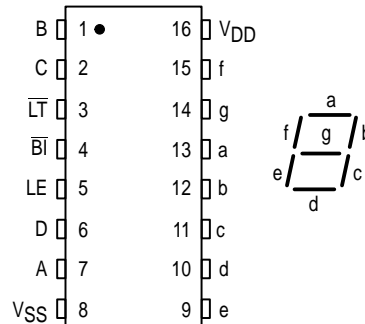

### DISPLAY

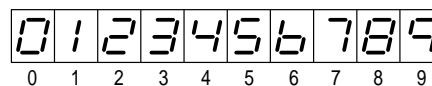

### TRUTH TABLE

Inputs				Outputs							
LE	BI	LT	D C B A	a	b	c	d	e	f	g	Display
X	X	0	X X X X	1	1	1	1	1	1	1	8
X	0	1	X X X X	0	0	0	0	0	0	0	Blank
0	1	1	0 0 0 0	1	1	1	1	1	1	0	0
0	1	1	0 0 0 1	0	1	1	0	0	0	0	1
0	1	1	0 0 1 1	1	1	1	1	1	0	0	2
0	1	1	0 0 1 0	0	1	1	1	1	0	0	3
0	1	1	0 1 0 0	0	1	1	0	0	0	1	4
0	1	1	0 1 0 1	1	0	1	1	1	1	1	5
0	1	1	0 1 1 0	0	0	1	1	1	1	1	6
0	1	1	0 1 1 1	1	1	1	0	0	0	0	7
0	1	1	1 0 0 0	0	1	1	1	1	1	1	8
0	1	1	1 0 0 1	1	1	1	0	0	1	1	9
0	1	1	1 0 1 0	0	0	0	0	0	0	0	Blank
0	1	1	1 0 1 1	0	0	0	0	0	0	0	Blank
0	1	1	1 1 0 0	0	0	0	0	0	0	0	Blank
0	1	1	1 1 0 1	0	0	0	0	0	0	0	Blank
0	1	1	1 1 1 0	0	0	0	0	0	0	0	Blank
0	1	1	1 1 1 1	0	0	0	0	0	0	0	Blank
1	1	1	X X X X	*	*	*	*	*	*	*	*

X = Don't Care

\* Depends upon the BCD code previously applied when LE = 0

**ELECTRICAL CHARACTERISTICS** (Voltages Referenced to V<sub>SS</sub>)

Characteristic	Symbol	V <sub>DD</sub> Vdc	-55°C		25°C			125°C		Unit	
			Min	Max	Min	Typ #	Max	Min	Max		
Output Voltage V <sub>in</sub> = V <sub>DD</sub> or 0	"0" Level V <sub>OL</sub>	5.0	—	0.05	—	0	0.05	—	0.05	Vdc	
		10	—	0.05	—	0	0.05	—	0.05		
		15	—	0.05	—	0	0.05	—	0.05		
	"1" Level V <sub>in</sub> = 0 or V <sub>DD</sub>	V <sub>OH</sub>	5.0	4.1	—	4.1	4.57	—	4.1		—
			10	9.1	—	9.1	9.58	—	9.1		—
			15	14.1	—	14.1	14.59	—	14.1		—
Input Voltage # (V <sub>O</sub> = 3.8 or 0.5 Vdc) (V <sub>O</sub> = 8.8 or 1.0 Vdc) (V <sub>O</sub> = 13.8 or 1.5 Vdc)	"0" Level V <sub>IL</sub>	5.0	—	1.5	—	2.25	1.5	—	1.5	Vdc	
		10	—	3.0	—	4.50	3.0	—	3.0		
		15	—	4.0	—	6.75	4.0	—	4.0		
	"1" Level (V <sub>O</sub> = 0.5 or 3.8 Vdc) (V <sub>O</sub> = 1.0 or 8.8 Vdc) (V <sub>O</sub> = 1.5 or 13.8 Vdc)	V <sub>IH</sub>	5.0	3.5	—	3.5	2.75	—	3.5		—
			10	7.0	—	7.0	5.50	—	7.0		—
			15	11	—	11	8.25	—	11		—
Output Drive Voltage Source (I <sub>OH</sub> = 0 mA) (I <sub>OH</sub> = 5.0 mA) (I <sub>OH</sub> = 10 mA) (I <sub>OH</sub> = 15 mA) (I <sub>OH</sub> = 20 mA) (I <sub>OH</sub> = 25 mA)	V <sub>OH</sub>	5.0	4.1	—	4.1	4.57	—	4.1	—	Vdc	
			—	—	—	4.24	—	—	—		
			3.9	—	3.9	4.12	—	3.5	—		
			—	—	—	3.94	—	—	—		
			3.4	—	3.4	3.70	—	3.0	—		
			—	—	—	3.54	—	—	—		
	V <sub>OH</sub>	10	9.1	—	9.1	9.58	—	9.1	—	Vdc	
			—	—	—	9.26	—	—	—		
			9.0	—	9.0	9.17	—	8.6	—		
			—	—	—	9.04	—	—	—		
			8.6	—	8.6	8.90	—	8.2	—		
			—	—	—	8.70	—	—	—		
V <sub>OH</sub>	15	14.1	—	14.1	14.59	—	14.1	—	Vdc		
		—	—	—	14.27	—	—	—			
		14	—	14	14.18	—	13.6	—			
		—	—	—	14.07	—	—	—			
		13.6	—	13.6	13.95	—	13.2	—			
		—	—	—	13.70	—	—	—			
Output Drive Current Sink (V <sub>OL</sub> = 0.4 V) (V <sub>OL</sub> = 0.5 V) (V <sub>OL</sub> = 1.5 V)	I <sub>OL</sub>	5.0	0.64	—	0.51	0.88	—	0.36	—	mAdc	
		10	1.6	—	1.3	2.25	—	0.9	—		
		15	4.2	—	3.4	8.8	—	2.4	—		
		—	—	—	—	—	—	—	—		
Input Current	I <sub>in</sub>	15	—	±0.1	—	±0.00001	±0.1	—	±1.0	μAdc	
Input Capacitance	C <sub>in</sub>	—	—	—	—	5.0	7.5	—	—	pF	
Quiescent Current (Per Package) V <sub>in</sub> = 0 or V <sub>DD</sub> , I <sub>out</sub> = 0 μA	I <sub>DD</sub>	5.0	—	5.0	—	0.005	5.0	—	150	μAdc	
		10	—	10	—	0.010	10	—	300		
		15	—	20	—	0.015	20	—	600		
Total Supply Current**† (Dynamic plus Quiescent, Per Package) (C <sub>L</sub> = 50 pF on all outputs, all buffers switching)	I <sub>T</sub>	5.0	I <sub>T</sub> = (1.9 μA/kHz) f + I <sub>DD</sub> I <sub>T</sub> = (3.8 μA/kHz) f + I <sub>DD</sub> I <sub>T</sub> = (5.7 μA/kHz) f + I <sub>DD</sub>							μAdc	
		10									
		15									

#Noise immunity specified for worst-case input combination.

Noise Margin for both "1" and "0" level =  
 1.0 Vdc min @ V<sub>DD</sub> = 5.0 Vdc  
 2.0 Vdc min @ V<sub>DD</sub> = 10 Vdc  
 2.5 Vdc min @ V<sub>DD</sub> = 15 Vdc

\*\*The formulas given are for the typical characteristics only at 25°C.

†To calculate total supply current at loads other than 50 pF:

$$I_T(C_L) = I_T(50 \text{ pF}) + 3.5 \times 10^{-3} (C_L - 50) V_{DD} f$$

where: I<sub>T</sub> is in μA (per package), C<sub>L</sub> in pF, V<sub>DD</sub> in Vdc, and f in kHz is input frequency.

**SWITCHING CHARACTERISTICS\*** ( $C_L = 50 \text{ pF}$ ,  $T_A = 25^\circ\text{C}$ )

Characteristic	Symbol	V <sub>DD</sub> Vdc	Min	Typ	Max	Unit
Output Rise Time $t_{TLH} = (0.40 \text{ ns/pF}) C_L + 20 \text{ ns}$ $t_{TLH} = (0.25 \text{ ns/pF}) C_L + 17.5 \text{ ns}$ $t_{TLH} = (0.20 \text{ ns/pF}) C_L + 15 \text{ ns}$	$t_{TLH}$	5.0 10 15	— — —	40 30 25	80 60 50	ns
Output Fall Time $t_{THL} = (1.5 \text{ ns/pF}) C_L + 50 \text{ ns}$ $t_{THL} = (0.75 \text{ ns/pF}) C_L + 37.5 \text{ ns}$ $t_{THL} = (0.55 \text{ ns/pF}) C_L + 37.5 \text{ ns}$	$t_{THL}$	5.0 10 15	— — —	125 75 65	250 150 130	ns
Data Propagation Delay Time $t_{PLH} = (0.40 \text{ ns/pF}) C_L + 620 \text{ ns}$ $t_{PLH} = (0.25 \text{ ns/pF}) C_L + 237.5 \text{ ns}$ $t_{PLH} = (0.20 \text{ ns/pF}) C_L + 165 \text{ ns}$  $t_{PHL} = (1.3 \text{ ns/pF}) C_L + 655 \text{ ns}$ $t_{PHL} = (0.60 \text{ ns/pF}) C_L + 260 \text{ ns}$ $t_{PHL} = (0.35 \text{ ns/pF}) C_L + 182.5 \text{ ns}$	$t_{PLH}$    $t_{PHL}$	5.0 10 15  5.0 10 15	— — —  — — —	640 250 175  720 290 200	1280 500 350  1440 580 400	ns
Blank Propagation Delay Time $t_{PLH} = (0.30 \text{ ns/pF}) C_L + 585 \text{ ns}$ $t_{PLH} = (0.25 \text{ ns/pF}) C_L + 187.5 \text{ ns}$ $t_{PLH} = (0.15 \text{ ns/pF}) C_L + 142.5 \text{ ns}$  $t_{PHL} = (0.85 \text{ ns/pF}) C_L + 442.5 \text{ ns}$ $t_{PHL} = (0.45 \text{ ns/pF}) C_L + 177.5 \text{ ns}$ $t_{PHL} = (0.35 \text{ ns/pF}) C_L + 142.5 \text{ ns}$	$t_{PLH}$    $t_{PHL}$	5.0 10 15  5.0 10 15	— — —  — — —	600 200 150  485 200 160	750 300 220  970 400 320	ns
Lamp Test Propagation Delay Time $t_{PLH} = (0.45 \text{ ns/pF}) C_L + 290.5 \text{ ns}$ $t_{PLH} = (0.25 \text{ ns/pF}) C_L + 112.5 \text{ ns}$ $t_{PLH} = (0.20 \text{ ns/pF}) C_L + 80 \text{ ns}$  $t_{PHL} = (1.3 \text{ ns/pF}) C_L + 248 \text{ ns}$ $t_{PHL} = (0.45 \text{ ns/pF}) C_L + 102.5 \text{ ns}$ $t_{PHL} = (0.35 \text{ ns/pF}) C_L + 72.5 \text{ ns}$	$t_{PLH}$    $t_{PHL}$	5.0 10 15  5.0 10 15	— — —  — — —	313 125 90  313 125 90	625 250 180  625 250 180	ns
Setup Time	$t_{su}$	5.0 10 15	100 40 30	— — —	— — —	ns
Hold Time	$t_h$	5.0 10 15	60 40 30	— — —	— — —	ns
Latch Enable Pulse Width	$t_{WL}$	5.0 10 15	520 220 130	260 110 65	— — —	ns

\* The formulas given are for the typical characteristics only.

This device contains protection circuitry to protect the inputs against damage due to high static voltages or electric fields; however, it is advised that normal precautions be taken to avoid application of any voltage higher than maximum rated voltages to this high-impedance circuit. A destructive high current mode may occur if  $V_{in}$  and  $V_{out}$  are not constrained to the range  $V_{SS} \leq (V_{in} \text{ or } V_{out}) \leq V_{DD}$ .

Due to the sourcing capability of this circuit, damage can occur to the device if  $V_{DD}$  is applied, and the outputs are shorted to  $V_{SS}$  and are at a logical 1 (See Maximum Ratings).

Unused inputs must always be tied to an appropriate logic voltage level (e.g., either  $V_{SS}$  or  $V_{DD}$ ).

Input LE low, and Inputs D,  $\overline{B}$ I and  $\overline{L}$ T high.  
 f in respect to a system clock.  
 All outputs connected to respective  $C_L$  loads.

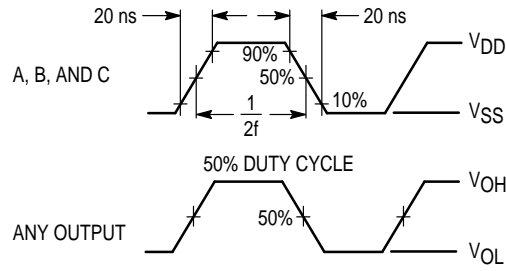

**Figure 1. Dynamic Power Dissipation Signal Waveforms**

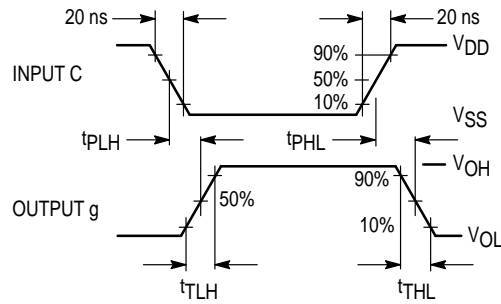

**(a) Inputs D and LE low, and Inputs A, B,  $\overline{B}$ I and  $\overline{L}$ T high.**

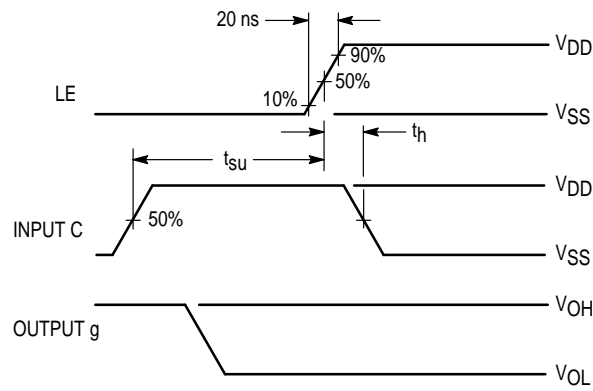

**(b) Input D low, Inputs A, B,  $\overline{B}$ I and  $\overline{L}$ T high.**

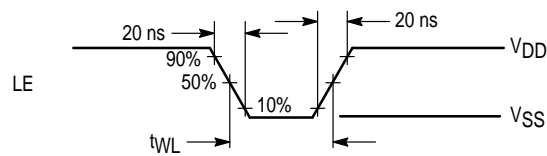

**(c) Data DCBA strobed into latches.**

**Figure 2. Dynamic Signal Waveforms**

## CONNECTIONS TO VARIOUS DISPLAY READOUTS

### LIGHT EMITTING DIODE (LED) READOUT

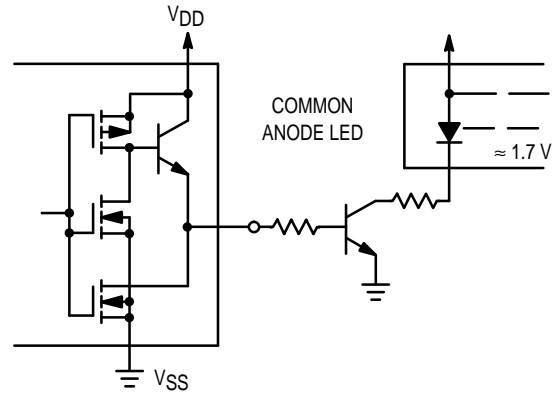
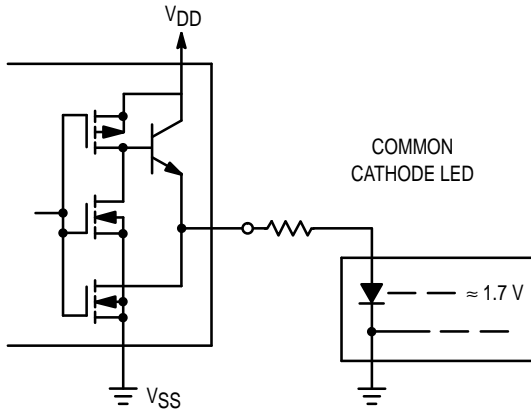

### INCANDESCENT READOUT

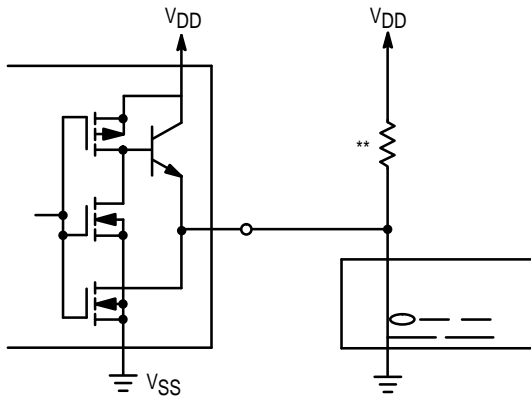

### FLUORESCENT READOUT

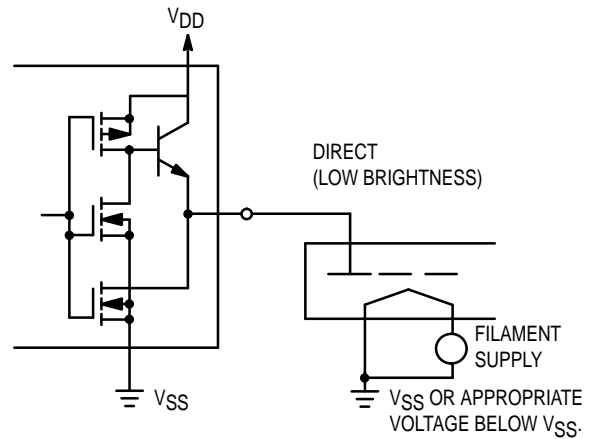

(CAUTION: Maximum working voltage = 18.0 V)

### GAS DISCHARGE READOUT

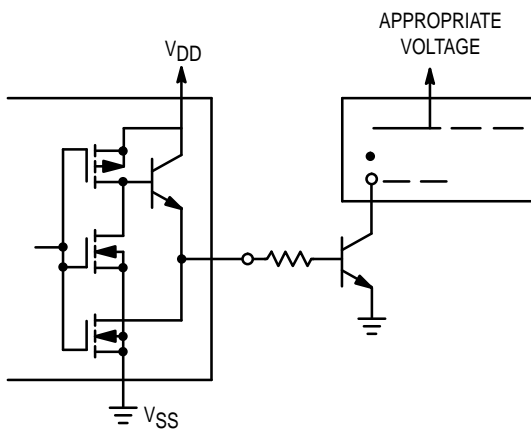

### LIQUID CRYSTAL (LCD) READOUT

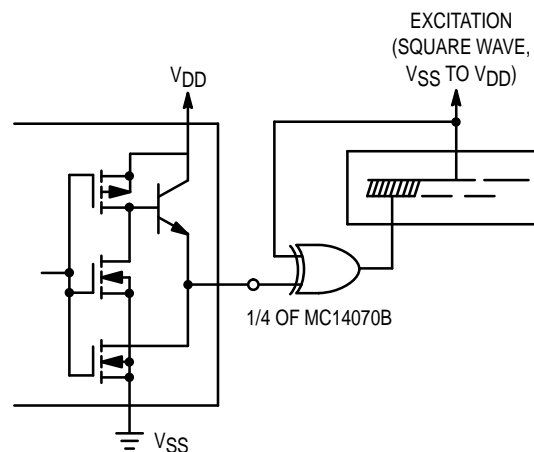

\*\* A filament pre-warm resistor is recommended to reduce filament thermal shock and increase the effective cold resistance of the filament.

Direct dc drive of LCD's not recommended for life of LCD readouts.

# LOGIC DIAGRAM

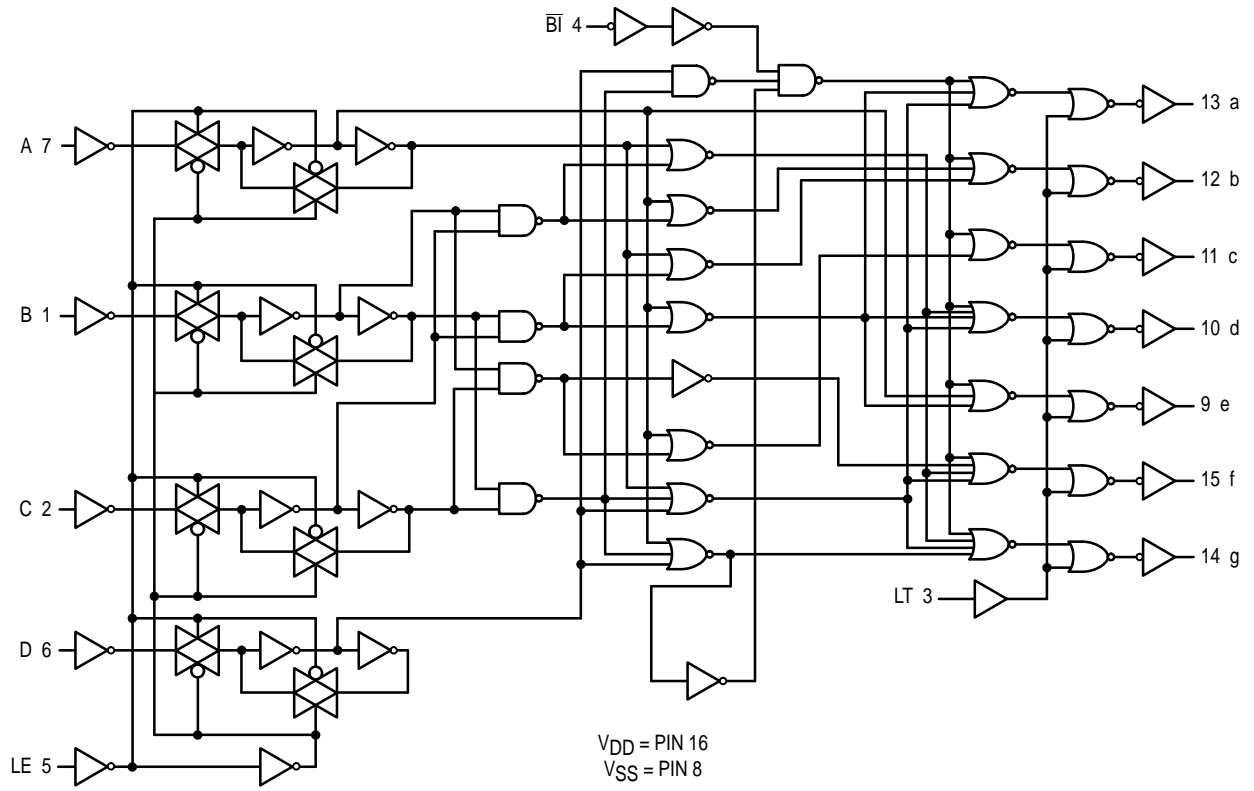

## OUTLINE DIMENSIONS

### L SUFFIX CERAMIC DIP PACKAGE CASE 620-10 ISSUE V

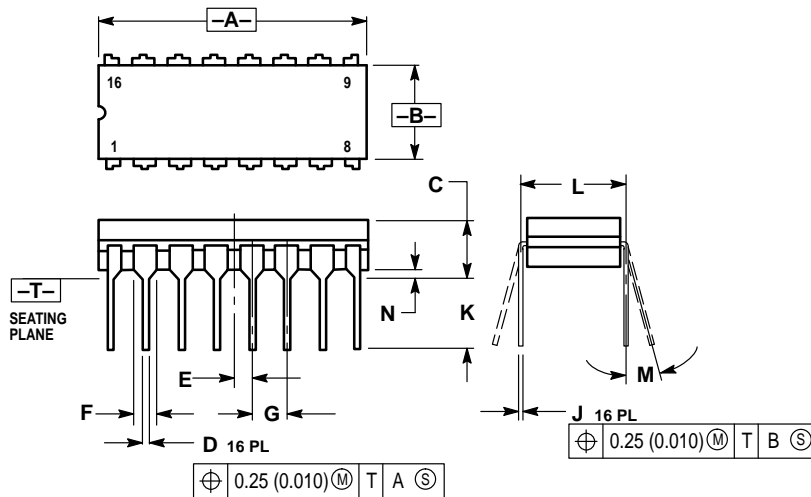

**NOTES:**

1. DIMENSIONING AND TOLERANCING PER ANSI Y14.5M, 1982.
2. CONTROLLING DIMENSION: INCH.
3. DIMENSION L TO CENTER OF LEAD WHEN FORMED PARALLEL.
4. DIMENSION F MAY NARROW TO 0.76 (0.030) WHERE THE LEAD ENTERS THE CERAMIC BODY.

DIM	INCHES		MILLIMETERS	
	MIN	MAX	MIN	MAX
A	0.750	0.785	19.05	19.93
B	0.240	0.295	6.10	7.49
C	—	0.200	—	5.08
D	0.015	0.020	0.39	0.50
E	0.050 BSC		1.27 BSC	
F	0.055	0.065	1.40	1.65
G	0.100 BSC		2.54 BSC	
H	0.008	0.015	0.21	0.38
K	0.125	0.170	3.18	4.31
L	0.300 BSC		7.62 BSC	
M	0°	15°	0°	15°
N	0.020	0.040	0.51	1.01

### P SUFFIX PLASTIC DIP PACKAGE CASE 648-08 ISSUE R

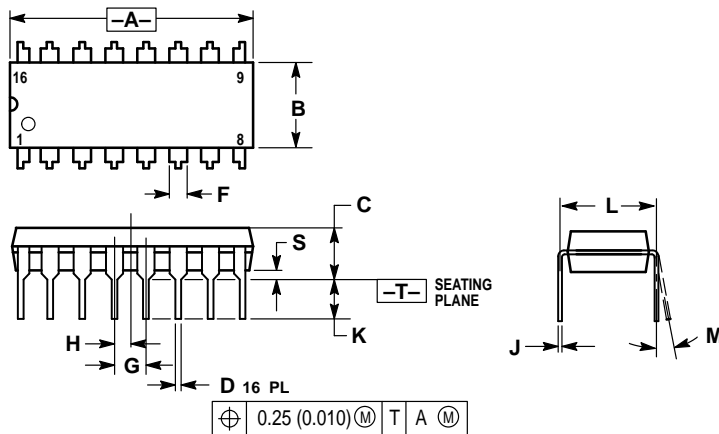

**NOTES:**

1. DIMENSIONING AND TOLERANCING PER ANSI Y14.5M, 1982.
2. CONTROLLING DIMENSION: INCH.
3. DIMENSION L TO CENTER OF LEADS WHEN FORMED PARALLEL.
4. DIMENSION B DOES NOT INCLUDE MOLD FLASH.
5. ROUNDED CORNERS OPTIONAL.

DIM	INCHES		MILLIMETERS	
	MIN	MAX	MIN	MAX
A	0.740	0.770	18.80	19.55
B	0.250	0.270	6.35	6.85
C	0.145	0.175	3.69	4.44
D	0.015	0.021	0.39	0.53
F	0.040	0.70	1.02	1.77
G	0.100 BSC		2.54 BSC	
H	0.050 BSC		1.27 BSC	
J	0.008	0.015	0.21	0.38
K	0.110	0.130	2.80	3.30
L	0.295	0.305	7.50	7.74
M	0°	10°	0°	10°
S	0.020	0.040	0.51	1.01

## OUTLINE DIMENSIONS

### D SUFFIX PLASTIC SOIC PACKAGE CASE 751B-05 ISSUE J

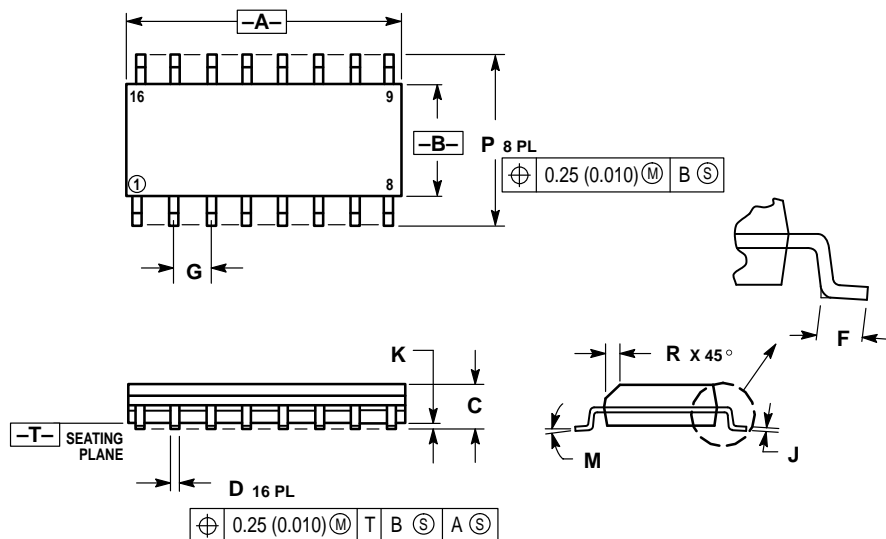

- NOTES:
1. DIMENSIONING AND TOLERANCING PER ANSI Y14.5M, 1982.
  2. CONTROLLING DIMENSION: MILLIMETER.
  3. DIMENSIONS A AND B DO NOT INCLUDE MOLD PROTRUSION.
  4. MAXIMUM MOLD PROTRUSION 0.15 (0.006) PER SIDE.
  5. DIMENSION D DOES NOT INCLUDE DAMBAR PROTRUSION. ALLOWABLE DAMBAR PROTRUSION SHALL BE 0.127 (0.005) TOTAL IN EXCESS OF THE D DIMENSION AT MAXIMUM MATERIAL CONDITION.

DIM	MILLIMETERS		INCHES	
	MIN	MAX	MIN	MAX
A	9.80	10.00	0.386	0.393
B	3.80	4.00	0.150	0.157
C	1.35	1.75	0.054	0.068
D	0.35	0.49	0.014	0.019
F	0.40	1.25	0.016	0.049
G	1.27 BSC		0.050 BSC	
J	0.19	0.25	0.008	0.009
K	0.10	0.25	0.004	0.009
M	0°	7°	0°	7°
P	5.80	6.20	0.229	0.244
R	0.25	0.50	0.010	0.019

### DW SUFFIX PLASTIC SOIC PACKAGE CASE 751G-02 ISSUE A

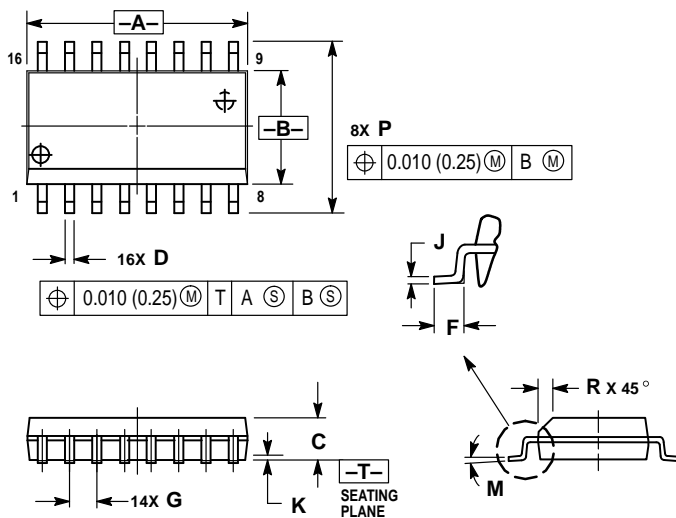

- NOTES:
1. DIMENSIONING AND TOLERANCING PER ANSI Y14.5M, 1982.
  2. CONTROLLING DIMENSION: MILLIMETER.
  3. DIMENSIONS A AND B DO NOT INCLUDE MOLD PROTRUSION.
  4. MAXIMUM MOLD PROTRUSION 0.15 (0.006) PER SIDE.
  5. DIMENSION D DOES NOT INCLUDE DAMBAR PROTRUSION. ALLOWABLE DAMBAR PROTRUSION SHALL BE 0.13 (0.005) TOTAL IN EXCESS OF D DIMENSION AT MAXIMUM MATERIAL CONDITION.

DIM	MILLIMETERS		INCHES	
	MIN	MAX	MIN	MAX
A	10.15	10.45	0.400	0.411
B	7.40	7.60	0.292	0.299
C	2.35	2.65	0.093	0.104
D	0.35	0.49	0.014	0.019
F	0.50	0.90	0.020	0.035
G	1.27 BSC		0.050 BSC	
J	0.25	0.32	0.010	0.012
K	0.10	0.25	0.004	0.009
M	0°	7°	0°	7°
P	10.05	10.55	0.395	0.415
R	0.25	0.75	0.010	0.029



Motorola reserves the right to make changes without further notice to any products herein. Motorola makes no warranty, representation or guarantee regarding the suitability of its products for any particular purpose, nor does Motorola assume any liability arising out of the application or use of any product or circuit, and specifically disclaims any and all liability, including without limitation consequential or incidental damages. "Typical" parameters which may be provided in Motorola data sheets and/or specifications can and do vary in different applications and actual performance may vary over time. All operating parameters, including "Typicals" must be validated for each customer application by customer's technical experts. Motorola does not convey any license under its patent rights nor the rights of others. Motorola products are not designed, intended, or authorized for use as components in systems intended for surgical implant into the body, or other applications intended to support or sustain life, or for any other application in which the failure of the Motorola product could create a situation where personal injury or death may occur. Should Buyer purchase or use Motorola products for any such unintended or unauthorized application, Buyer shall indemnify and hold Motorola and its officers, employees, subsidiaries, affiliates, and distributors harmless against all claims, costs, damages, and expenses, and reasonable attorney fees arising out of, directly or indirectly, any claim of personal injury or death associated with such unintended or unauthorized use, even if such claim alleges that Motorola was negligent regarding the design or manufacture of the part. Motorola and  are registered trademarks of Motorola, Inc. Motorola, Inc. is an Equal Opportunity/Affirmative Action Employer.

**How to reach us:**

**USA/EUROPE/Locations Not Listed:** Motorola Literature Distribution;  
P.O. Box 20912; Phoenix, Arizona 85036. 1-800-441-2447 or 602-303-5454

**MFAX:** RMFAX0@email.sps.mot.com – TOUCHTONE 602-244-6609  
**INTERNET:** <http://Design-NET.com>

**JAPAN:** Nippon Motorola Ltd.; Tatsumi-SPD-JLDC, 6F Seibu-Butsuryu-Center,  
3-14-2 Tatsumi Koto-Ku, Tokyo 135, Japan. 03-81-3521-8315

**ASIA/PACIFIC:** Motorola Semiconductors H.K. Ltd.; 8B Tai Ping Industrial Park,  
51 Ting Kok Road, Tai Po, N.T., Hong Kong. 852-26629298



**MOTOROLA**



MC14511B/D

