

Quad Voltage Comparators for Industrial, Commercial and Military Applications

The devices in this series consist of four independent single or dual supply voltage comparators on a single monolithic substrate. The common mode input voltage range includes ground even when operated from a single supply, and the low power supply current drain makes these comparators suitable for battery operation. These types were designed to directly interface with TTL and CMOS.

Type CA139A, has a lower input offset voltage than the CA139. Some of the SOIC parts are available on tape and reel (see Ordering Information table). Replace the M suffix in the part number with M96 when ordering (e.g., CA0239M96).

Part Number Information

PART NO. (BRAND)	TEMP. RANGE (°C)	PACKAGE	PKG. NO.
CA0139E	-55 to 125	14 Ld PDIP	E14.3
CA0139M, AM (139, 139A)	-55 to 125	14 Ld SOIC	M14.15
CA0239E	-25 to 85	14 Ld PDIP	E14.3
CA0239M96 (239)	-25 to 85	14 Ld SOIC	M14.15
CA0339E	0 to 70	14 Ld PDIP	E14.3
CA0339M (339)	0 to 70	14 Ld SOIC	M14.15
LM339N	0 to 70	14 Ld PDIP	E14.3
LM2901N	-40 to 85	14 Ld PDIP	E14.3
LM3302M96 (3302)	-40 to 85	14 Ld SOIC	M14.15
LM3302N	-40 to 85	14 Ld PDIP	E14.3

Pinout

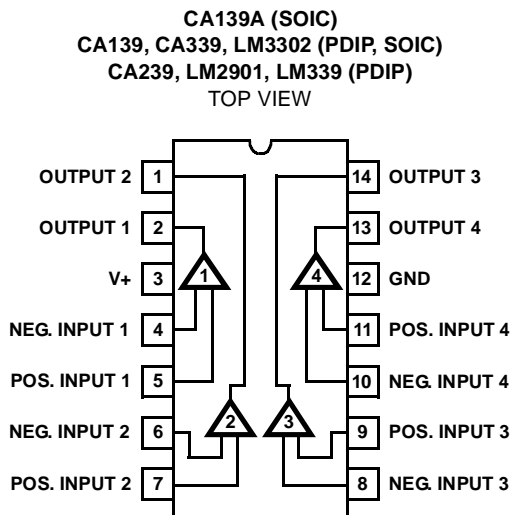

Features

- Operation from Single or Dual Supplies
- Common Mode Input Voltage Range to GND
- Output Voltage Compatible with TTL, DTL, ECL, MOS and CMOS
- Differential Input Voltage Range Equal to the Supply Voltage
- Maximum Input Offset Voltage (V_{IO})
 - CA139A 2mV
 - CA139, CA239, CA339 5mV
 - LM2901 7mV
 - LM3302 20mV
- Replacement for Industry Types 139, 239, 339, 139A, 2901, 3302

Applications

- Square Wave Generator
- Time Delay Generators
- Pulse Generators
- Multivibrators
- High Voltage Digital Logic Gates
- A/D Converters
- MOS Clock Timers

Schematic Diagram

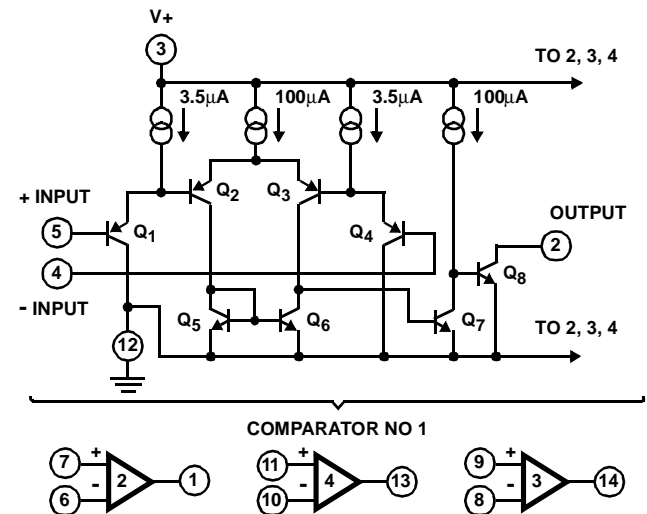

CA139, CA139A, CA239, CA339, LM339, LM2901, LM3302

Absolute Maximum Ratings

Supply Voltage	36V or ±18V
Differential Input Voltage	36V
Input Voltage	-0.3V to +36V
Input Current ($V_I < -0.3V$, Note 1)	50mA
Output Short Circuit Duration (Single Supply, Note 2)	Continuous

Operating Conditions

Temperature Range	
CA139, CA139A	-55°C to 125°C
CA239	-25°C to 80°C
CA339, LM339	0°C to 70°C
LM2901, LM3302	-40°C to 85°C

Thermal Information

Thermal Resistance (Typical, Note 3)	θ_{JA} (°C/W)	θ_{JC} (°C/W)
PDIP Package	100	N/A
SOIC Package	175	N/A
Maximum Junction Temperature (Plastic Package)	150°C	
Maximum Storage Temperature Range	-65°C to 150°C	
Maximum Lead Temperature (Soldering 10s)	300°C (SOIC - Lead Tips Only)	

CAUTION: Stresses above those listed in "Absolute Maximum Ratings" may cause permanent damage to the device. This is a stress only rating and operation of the device at these or any other conditions above those indicated in the operational sections of this specification is not implied.

NOTES:

- Inputs must not go more negative than -0.3V.
- Short circuits from the output to V+ can cause excessive heating and eventual destruction. The maximum output current independent of V+ is approximately 20mA.
- θ_{JA} is measured with the component mounted on an evaluation PC board in free air.

Electrical Specifications $V_+ = 5V$, Unless Otherwise Specified

PARAMETER	SYMBOL	TEST CONDITIONS	TEMP (°C)	CA139			CA139A			UNITS
				MIN	TYP	MAX	MIN	TYP	MAX	
Input Offset Voltage	V_{IO}	$V_{REF} = 1.4V$, $R_S = 0$, Output Switch Point $V \cong 1.4V$	$T_A = 25$	-	2	5	-	1	2	mV
			Note 4	-	-	9	-	-	4	mV
Differential Input Voltage	V_{ID}	Keep All Inputs $\dot{S} \geq 0V$, or V- (if used), (Note 5)	Note 4	-	-	36	-	-	36	V
Saturation Voltage	V_{SAT}	$V_{I-} = 1V$, $V_{I+} = 0V$, $I_{SINK} \leq 4mA$	$T_A = 25$	-	250	400	-	250	400	mV
			Note 4	-	-	700	-	-	700	mV
Common Mode Input Voltage Range	V_{ICR}	Note 6	$T_A = 25$	0	-	$V_+ - 1.5$	0	-	$V_+ - 1.5$	V
			Note 4	0	-	$V_+ - 2$	0	-	$V_+ - 2$	V
Input Offset Current	I_{IO}	$I_{I+} - I_{I-}$	$T_A = 25$	-	3	25	-	3	25	nA
			Note 4	-	-	100	-	-	100	nA
Input Bias Current	I_{IB}	I_{I+} or I_{I-} with Output in Linear Range	$T_A = 25$	-	25	100	-	25	100	nA
			Note 4	-	-	300	-	-	300	nA
Total Supply Current	I_+	$R_L = \infty$ On All Comparators	$T_A = 25$	-	0.8	2	-	0.8	2	mA
Output Leakage Current		$V_{I+} \geq 1V$, $V_{I-} = 0V$, $V_O = 5V$	$T_A = 25$	-	0.1	-	-	0.1	-	nA
		$V_{I+} \geq 1V$, $V_{I-} = 0V$, $V_O = 30V$	Note 4	-	-	1	-	-	1	μA
Output Sink Current		$V_{I-} \geq 1V$, $V_{I+} = 0V$, $V_O \leq 1.5V$	$T_A = 25$	6	16	-	6	16	-	mA
Voltage Gain	A_{OL}	$R_L \geq 15k\Omega$, $V_+ = 15V$	$T_A = 25$	-	200	-	50	200	-	V/mV
Large Signal Response Time		$V_I = TTL$ Logic Swing, $V_{REF} = 1.4V$, $V_{RL} = 5V$, $R_L = 5.1k\Omega$	$T_A = 25$	-	300	-	-	300	-	ns
Response Time (Figures 3, 4)		$V_{RL} = 5V$, $R_L = 5.1k\Omega$	$T_A = 25$	-	1.3	-	-	1.3	-	μs

Electrical Specifications $V_+ = 5V$, Unless Otherwise Specified

PARAMETER	SYMBOL	TEST CONDITIONS	TEMP (°C)	CA239, CA339, LM339			UNITS
				MIN	TYP	MAX	
Input Offset Voltage	V_{IO}	$V_{REF} = 1.4V$, $R_S = 0$, Output Switch Point $V \cong 1.4V$	$T_A = 25$	-	2	5	mV
			Note 4	-	-	9	mV
Differential Input Voltage	V_{ID}	Keep All Inputs $\dot{S} \dot{S} \geq 0V$, or V_- (if used) (Note 5)	Note 4	-	-	36	V
Saturation Voltage	V_{SAT}	$V_{I-} = 1V$, $V_{I+} = 0V$, $I_{SINK} \leq 4mA$	$T_A = 25$	-	250	400	mV
			Note 4	-	-	700	mV
Common Mode Input Voltage Range	V_{ICR}	Note 6	$T_A = 25$	0	-	$V_+ - 1.5$	V
			Note 4	0	-	$V_+ - 2$	V
Input Offset Current	I_{IO}	$I_{I+} - I_{I-}$	$T_A = 25$	-	5	50	nA
			Note 4	-	-	150	nA
Input Bias Current	I_{IB}	I_{I+} or I_{I-} with Output in Linear Range	$T_A = 25$	-	25	250	nA
			Note 4	-	-	400	nA
Total Supply Current	I_+	$R_L = \infty$ on All Comparators	$T_A = 25$	-	0.8	2	mA
Output Leakage Current		$V_{I+} \geq 1V$, $V_{I-} = 0V$, $V_O = 5V$	$T_A = 25$	-	0.1	-	nA
		$V_{I+} \geq 1V$, $V_{I-} = 0V$, $V_O = 30V$	Note 4	-	-	1	μA
Output Sink Current		$V_{I-} \geq 1V$, $V_{I+} = 0V$, $V_O \leq 1.5V$	$T_A = 25$	6	16	-	mA
Voltage Gain	A_{OL}	$R_L \geq 15k\Omega$, $V_+ = 15V$	$T_A = 25$	50	200	-	V/mV
Large Signal Response Time		$V_I = TTL$ Logic Swing, $V_{REF} = 1.4V$, $V_{RL} = 5V$, $R_L = 5.1k\Omega$	$T_A = 25$	-	300	-	ns
Response Time (Figures 3, 4)		$V_{RL} = 5V$, $R_L = 5.1k\Omega$	$T_A = 25$	-	1.3	-	μs

NOTES:

- Ambient Temperature (T_A) applicable over operating temperature range as shown below.
CA139, CA139A = $-55^\circ C$ to $125^\circ C$; CA239 = $-25^\circ C$ to $85^\circ C$; CA339, LM339 = $0^\circ C$ to $70^\circ C$; LM2901, LM3302 = $-40^\circ C$ to $85^\circ C$.
- The comparator will provide a proper output state even if the positive swing of the inputs exceeds the power supply voltage level, if the other input remains within the common mode voltage range. The low input voltage state must not be less than $-0.3V$ (or $0.3V$ below the magnitude of the negative power supply, if used).
- The upper end of the common mode voltage range is $(V_+) - 1.5V$, but either or both inputs can go to $+30V$ without damage.

Electrical Specifications $V_+ = 5V$, Unless Otherwise Specified

PARAMETER	SYMBOL	TEST CONDITIONS	TEMP (°C)	LM2901			LM3302			UNITS
				MIN	TYP	MAX	MIN	TYP	MAX	
Input Offset Voltage	V_{IO}	$V_{REF} = 1.4V, R_S = 0$, Output Switch Point $V \cong 1.4V$	$T_A = 25$	-	2	7	-	1	20	mV
			Note 4	-	-	15	-	-	40	mV
Differential Input Voltage	V_{ID}	Keep All Inputs $\geq 0V$, or V_- (if used), (Note 5)	Note 4	-	-	36	-	-	28	V
Saturation Voltage	V_{SAT}	$V_{I-} = 1V, V_{I+} = 0V$, $I_{SINK} \leq 4mA$	$T_A = 25$	-	250	400	-	250	500	mV
			Note 4	-	-	700	-	-	700	mV
Common Mode Input Voltage Range	V_{ICR}	Note 6	$T_A = 25$	0	-	$V_+ - 1.5$	0	-	$V_+ - 1.5$	V
			Note 4	0	-	$V_+ - 2$	0	-	$V_+ - 2$	V
Input Offset Current	I_{IO}	$I_{I+} - I_{I-}$	$T_A = 25$	-	5	50	-	3	100	nA
			Note 4	-	-	200	-	-	300	nA
Input Bias Current	I_{IB}	I_{I+} or I_{I-} with Output in Linear Range	$T_A = 25$	-	25	250	-	25	500	nA
			Note 4	-	-	500	-	-	1000	nA
Total Supply Current	I_+	$R_L = \infty$ on All Comparators	$T_A = 25$	-	0.8	2	-	0.8	2	mA
Output Leakage Current		$V_{I+} \geq 1V, V_{I-} = 0V$, $V_O = 5V$	$T_A = 25$	-	0.1	-	-	0.1	-	nA
		$V_{I+} \geq 1V, V_{I-} = 0V$, $V_O = 30V$	Note 4	-	-	1	-	-	1	μA
Output Sink Current		$V_{I-} \geq 1V, V_{I+} = 0V$, $V_O \leq 1.5V$	$T_A = 25$	6	16	-	6	16	-	mA
Voltage Gain	A_{OL}	$R_L \geq 15k\Omega, V_+ = 15V$	$T_A = 25$	25	100	-	2	30	-	V/mV
Large Signal Response Time		$V_I =$ TTL Logic Swing, $V_{REF} = 1.4V$, $V_{RL} = 5V, R_L = 5.1k\Omega$	$T_A = 25$	-	300	-	-	300	-	ns
Response Time (Figures 3, 4)		$V_{RL} = 5V, R_L = 5.1k\Omega$	$T_A = 25$	-	1.3	-	-	1.3	-	μs

Typical Performance Curves

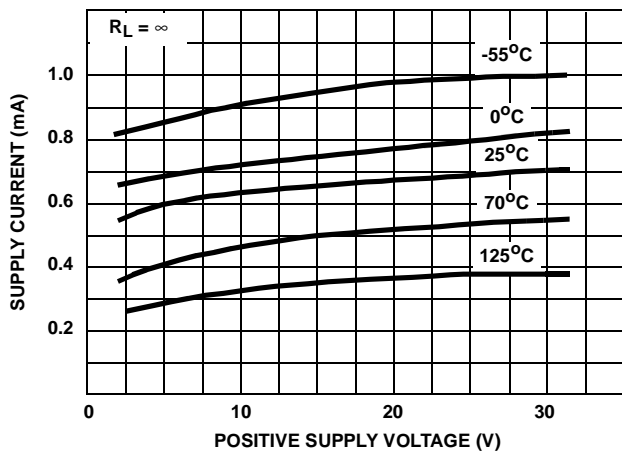

FIGURE 1. SUPPLY CURRENT vs SUPPLY VOLTAGE

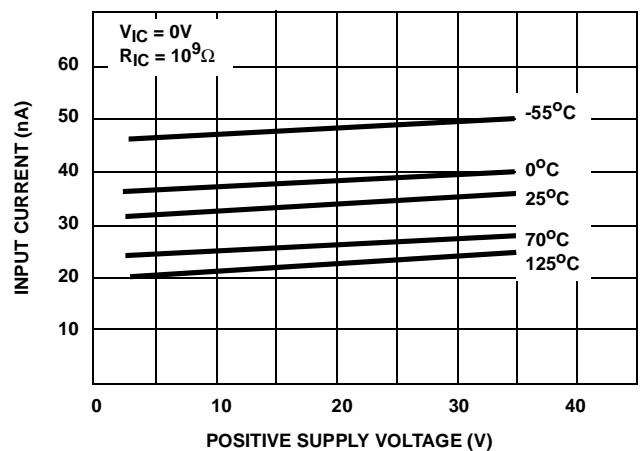

FIGURE 2. INPUT CURRENT vs SUPPLY VOLTAGE

Typical Performance Curves

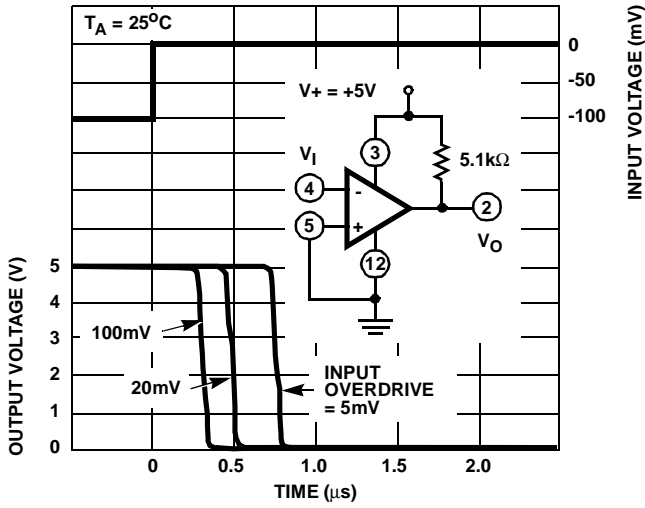

FIGURE 3. RESPONSE TIME FOR VARIOUS INPUT OVERDRIVES - NEGATIVE TRANSITION

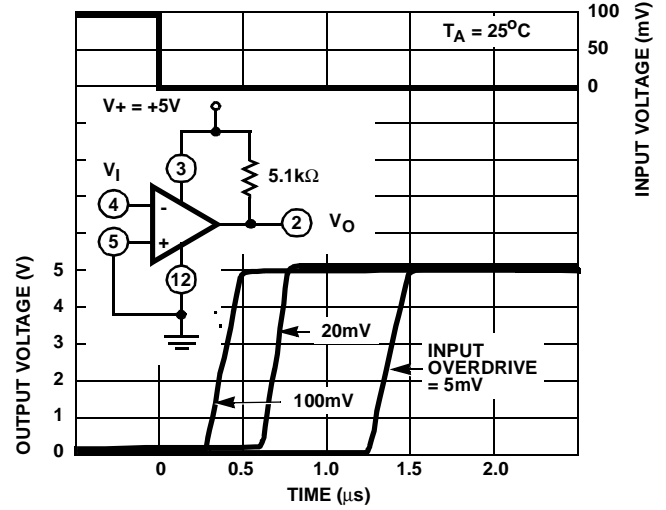

FIGURE 4. RESPONSE TIME FOR VARIOUS INPUT OVERDRIVES - POSITIVE TRANSITION

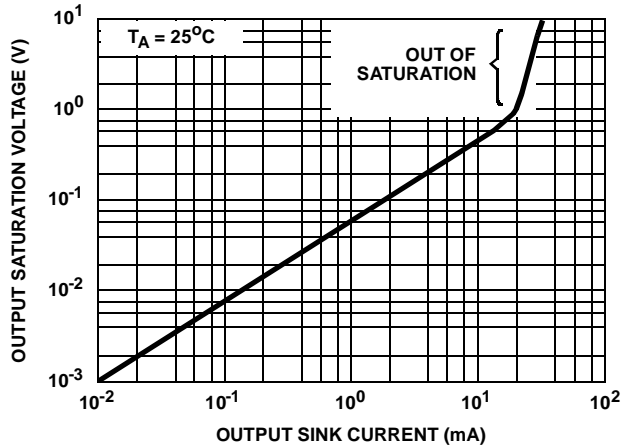
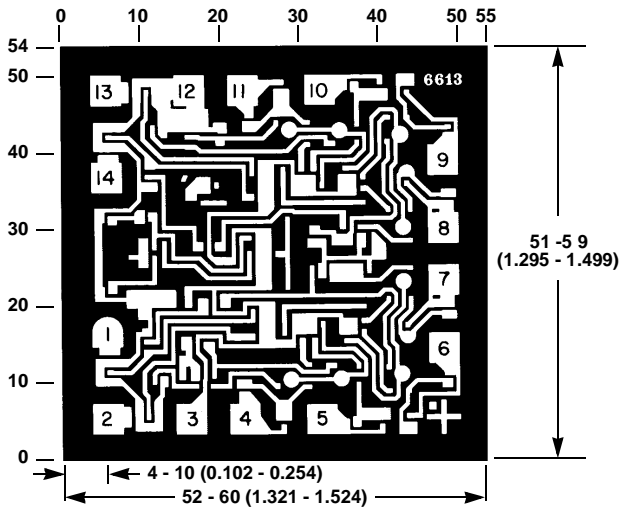

FIGURE 5. OUTPUT SATURATION VOLTAGE vs OUTPUT SINK CURRENT

Metallization Mask Layout



NOTE: Dimensions in parentheses are in mm and are derived from the basic in. dimensions as indicated. Grid graduations are in mils (10^{-3} inch).

All Intersil products are manufactured, assembled and tested utilizing ISO9000 quality systems.

Intersil Corporation's quality certifications can be viewed at website www.intersil.com/design/quality/iso.asp.

Intersil products are sold by description only. Intersil Corporation reserves the right to make changes in circuit design and/or specifications at any time without notice. Accordingly, the reader is cautioned to verify that data sheets are current before placing orders. Information furnished by Intersil is believed to be accurate and reliable. However, no responsibility is assumed by Intersil or its subsidiaries for its use; nor for any infringements of patents or other rights of third parties which may result from its use. No license is granted by implication or otherwise under any patent or patent rights of Intersil or its subsidiaries.

For information regarding Intersil Corporation and its products, see web site www.intersil.com

Sales Office Headquarters

NORTH AMERICA

Intersil Corporation
2401 Palm Bay Rd.
Palm Bay, FL 32905
TEL: (321) 724-7000
FAX: (321) 724-7240

EUROPE

Intersil SA
Mercure Center
100, Rue de la Fusee
1130 Brussels, Belgium
TEL: (32) 2.724.2111
FAX: (32) 2.724.22.05

ASIA

Intersil Ltd.
8F-2, 96, Sec. 1, Chien-kuo North,
Taipei, Taiwan 104
Republic of China
TEL: 886-2-2515-8508
FAX: 886-2-2515-8369